



INSTALLATION GUIDE

BEFORE YOU START

- To ensure that the installation and erection of your Stratco Handi-Mate™ Shed proceeds smoothly you should confirm that all the components and materials listed on the delivery documentation and in this installation guide have been supplied. Details for ordering individual components can be found in the "Component Index" section at the end of this document.
- Carefully read this installation guide to familiarise yourself with all the steps involved and ensure that you have the correct tools and equipment for the job.
- There are different types and colours of screws. Ensure that the right type and colour screw is being used at each location.
- Use heavy gloves when handling steel sheeting and flashings and never attempt to install a shed in windy conditions.
- It is important that you contact your local government authority to determine if building approval is required.
- Stability and performance of the shed relies on the door being closed during high wind events.
- It is essential to clear and level the site prior to assembling your Stratco Handi-Mate™ Shed.
- Do not traverse the roof of the Handi-Mate™.
- The installer is responsible for ensuring the slab or concrete pads are sufficient to support the shed and sustain wind loading. Do not directly anchor your shed to pavers. All Stratco Handi-Mate™ Sheds must be securely bolted to a permanent concrete base with sufficient masonry anchors as specified in Figure 8.4 to prevent wind uplift.

Option 1 - Before building the shed, pour a base that is larger than the area by at least 200mm in each direction. The base should be poured so the concrete outside the shed floor area slopes away from the shed to help prevent water from entering the shed.

Option 2 - Substantial concrete pads may be used at each anchor location as an alternative to a complete concrete floor. It is recommended pads are minimum Ø250mm x 400mm deep, embedded into a firm natural soil base.

- Where necessary, components are marked with a coloured sticker as to easily differentiate one from another. Components are referenced throughout the installation guide by their colour. For example, Panel (Short) is marked with a red ● sticker.







SHED WINDOWS (OPTIONAL)

Stratco Shed Windows are available as an optional add-on, available in both Louvre and Sliding variations. Handi-Mate Windows should be purchased along side the Handi-Mate Shed and installed during the Handi-Mate Shed assembly. Refer to the "Window Installation" section if installing a Stratco Window, or visit your local Stratco store for more information.

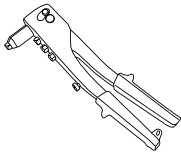
HANDI-MATE™ HML LOCKER SHED

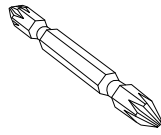
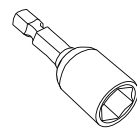
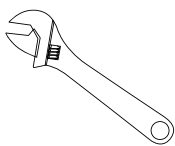
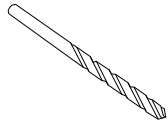
HANDI-MATE™ HML LOCKER SHED INSTALLATION GUIDE

TOOLS REQUIRED

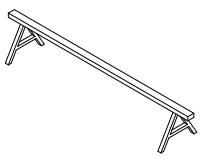
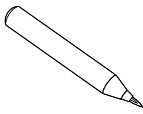
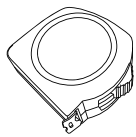
Rivet Gun 	Power Drill 	PH2 Phillips Head Bit (Supplied) 	5/16 - 8mm Hex Head Bit (Supplied) 	Adjustable Spanner 	3.5mm Bit (Supplied) 12mm Bit 10mm Masonry Bit 
Gloves 	Safety Glasses 	Step Ladder 	2 x Trestles 	Permanent Marker 	Tape Measure 

HANDI-MATE™ DIMENSIONS

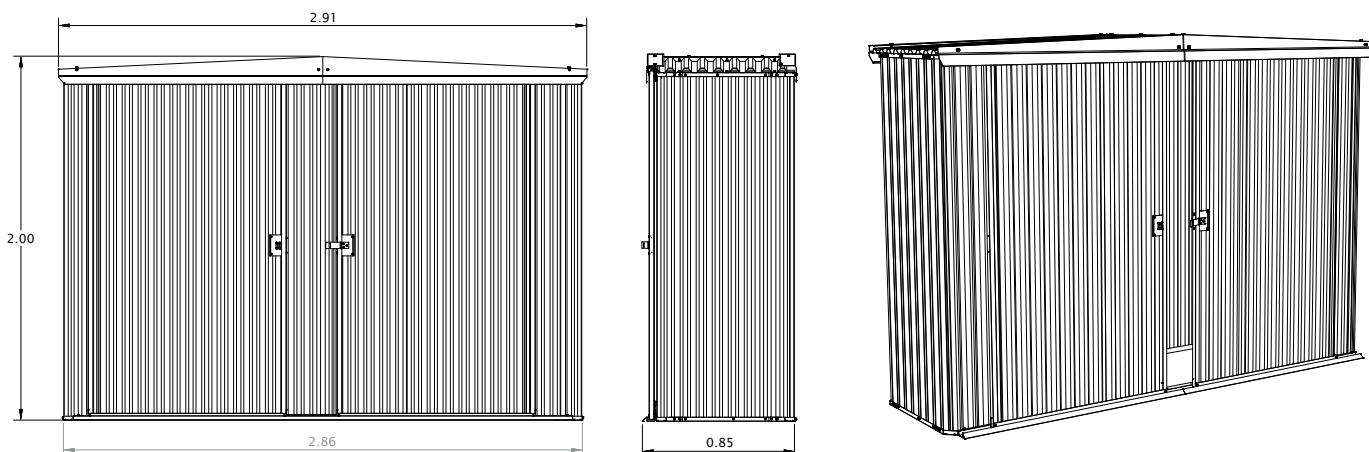



HANDI-MATE™ SHED WINDOWS

Stratco Handi-Mate Shed Windows are available as an optional add-on. For HML size Handi-Mates, the Window can be installed to the rear wall. Handi-Mate Windows should be installed during the Handi-Mate Shed assembly.



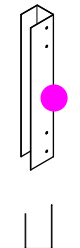
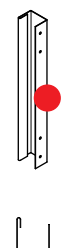
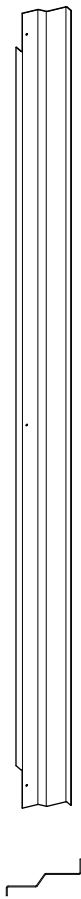
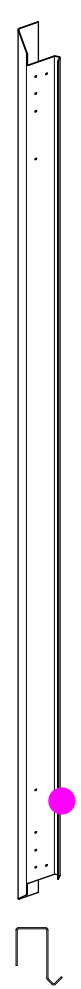
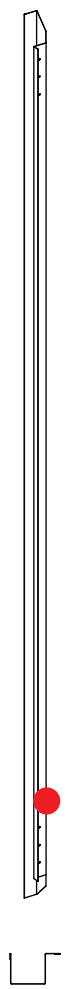
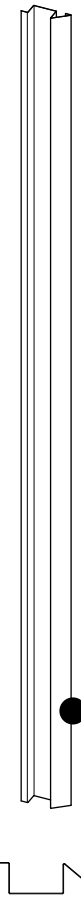
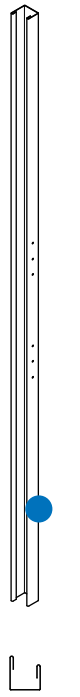
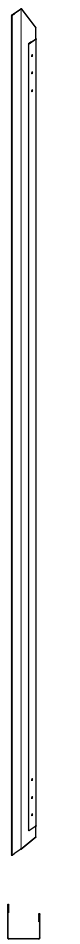
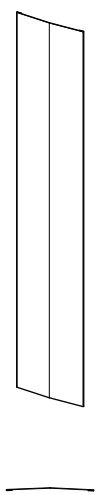
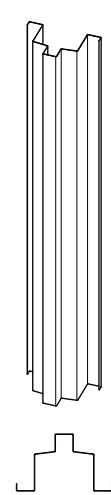
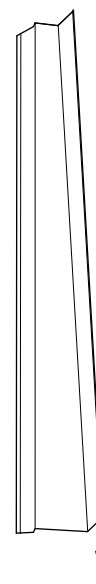

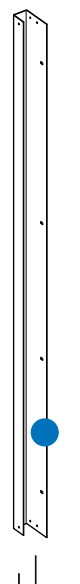
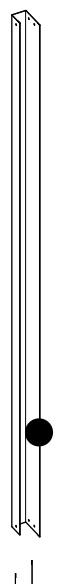
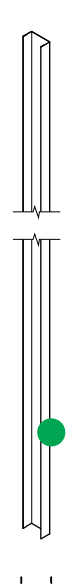
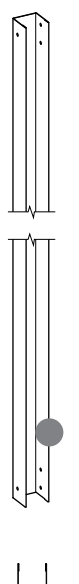
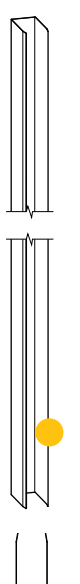





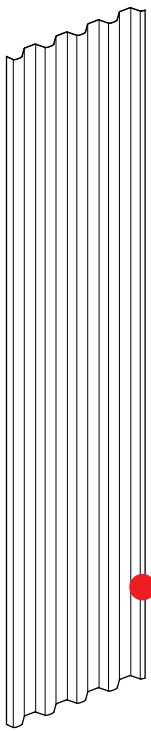
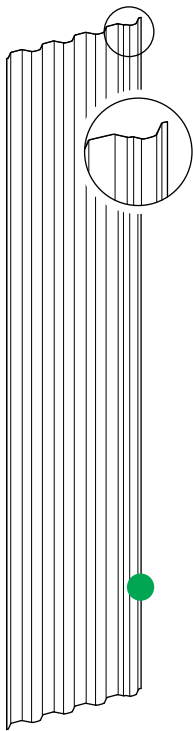
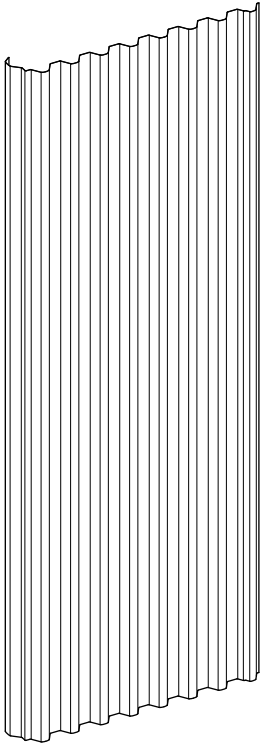
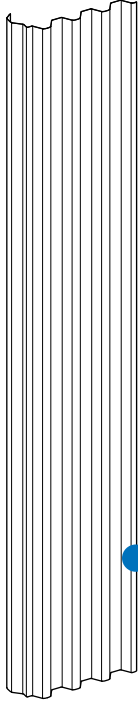
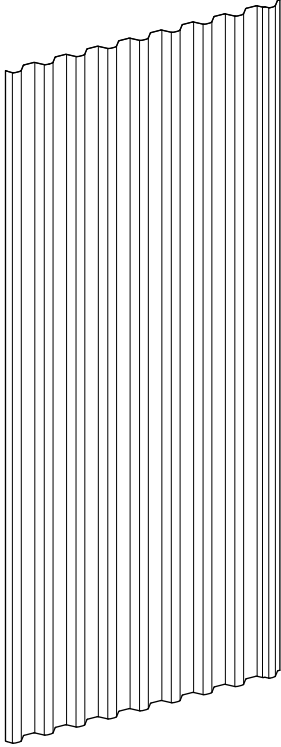
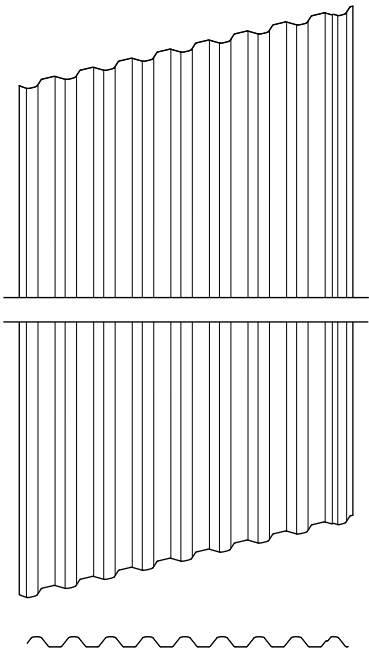

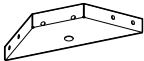

Refer to the "Window Installation" section at the end of this document if installing a Stratco Window, or visit a Stratco store for more information.

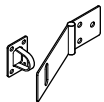
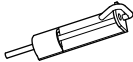
COMPONENTS

<p>Sliding Rail Joiner x 1</p> 	<p>Bottom Channel Joiner x 1</p> 	<p>Barge Support x 2</p> 	<p>Sliding Rail x 2</p> 	<p>Bottom Channel x 2</p> 	<p>Runner Rail x 2</p> 	<p>Wall Channel Joiner x 2</p> 	<p>Wall Channel Short x 4 Long x 4</p> 
<p>Ridge Cap x 1</p> 	<p>Ridge Beam x 1</p> 						
<p>L/H Barge Cap x 2</p> 	<p>R/H Barge Cap x 2</p> 	<p>Top Door Channel x 2</p> 	<p>Bottom Door Channel x 2</p> 	<p>Door Shroud x 1</p> 	<p>Vertical Door Channel x 4</p> 	<p>Door Jamb x 2</p> 	

HANDI-MATE™ HML LOCKER SHED INSTALLATION GUIDE

COMPONENTS

<p>Split Wall Sheet x 1</p> 	<p>Split Door Sheet x 2</p> 	<p>Corner Wall Sheet x 3</p> 	<p>Split Corner Wall Sheet x 1</p> 	<p>Wall Sheet x 5</p> 	
<p>Roof Sheet x 2</p> 	<p>Door Wheel x 4</p> 	<p>Door Nut x 4</p> 	<p>Door Stop x 4</p> 	<p>Corner Bracket x 8</p> 	<p>Handle Mount x 4</p> 
<p>Hasp & Staple x 1</p> 	<p>Padbolt x 1</p> 	<p>Hold Down Lug x 4</p> 	<p>M8x47 Masonry Anchor x 8</p> 	<p>Coloured Rivet x 15</p> 	
<p>10x16 Wafer-Head Screw x 55</p> 	<p>10x22 Wafer-Head Screw x 6</p> 	<p>10x16 Hex-Head Screw x 110</p> 	<p>10x16 Hex-Head Coloured Screw (with neo washer) x 28</p> 		
<p>10x25 Hex-Head Coloured Screw (with neo washer) x 22</p> 					

ASSEMBLY HANDY HINTS

The 'Sheet Crest', as referenced throughout this guide, refers to the curved top faces of the sheet.

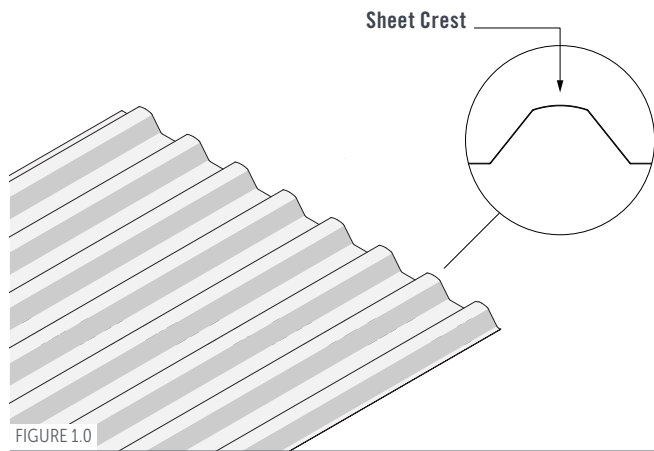

FIGURE 1.0

When assembling the Wall and Door Sheets, lay the sheets down on trestles/blocks (Figure 1.1). This will make assembly easier and reduce the risk of damage to components.

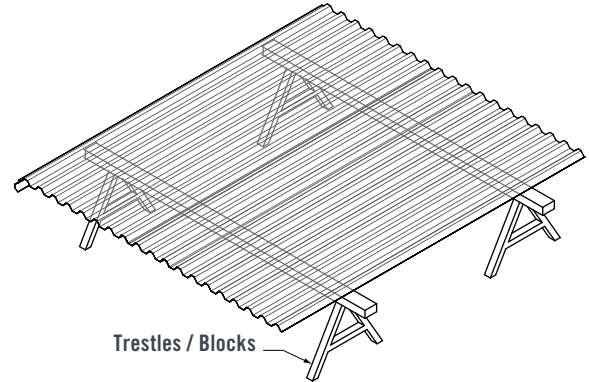

FIGURE 1.1

(Optional) Drainage holes can be drilled to help trapped water flow out of the bottom Wall Channels. After assembling the Walls, drill 6mm holes spaced approximately 350mm apart through the bottom Wall Channels of each Wall. Ensure holes are located in-between Sheet crests. Ensure metal filings are removed from the channels as to prevent rust spots from forming.

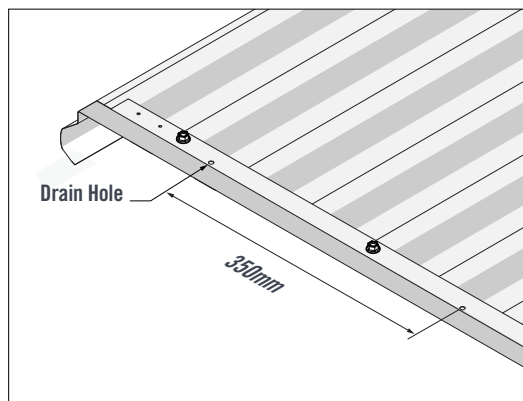
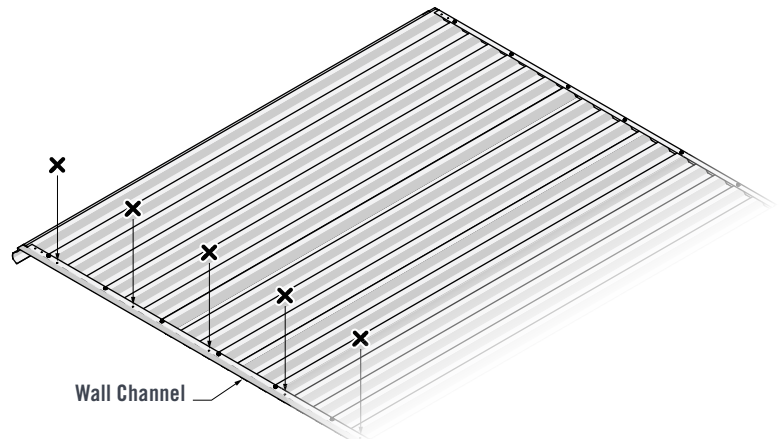

FIGURE 1.2



CHANNEL ASSEMBLIES

Slide two Wall Channels (Short) into a **Wall Channel Joiner**. Ensure the six middle pre-punched holes of the **Wall Channel Joiner** and **Wall Channels (Short)** line up. Fasten four 10x16 Hex-Head Screws through the four middle pilot holes of the **Wall Channel Joiner** and into the **Wall Channels** (Figure 2.0).

Assemble another Wall Channel Assembly in the same manner so that there are two Wall Channel Assemblies.

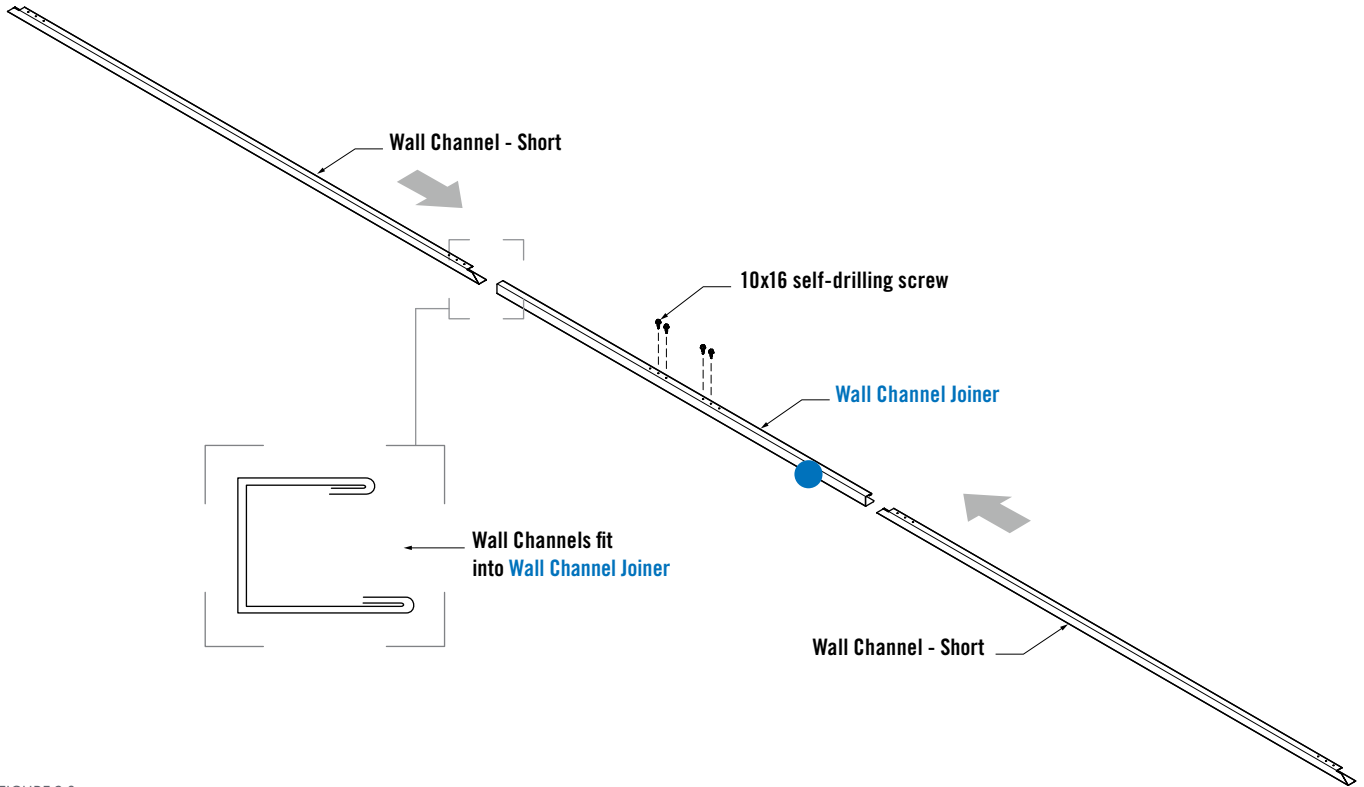

FIGURE 2.0

Slide both **Bottom Channels** into the **Bottom Channel Joiner**. Ensure the four middle pre-punched holes of the **Bottom Channel Joiner** and **Bottom Channels** line up.

Fasten four 10x16 Hex-Head Screws through the four middle pilot holes of the **Bottom Channel Joiner** and into the **Bottom Channels** (Figure 2.1).

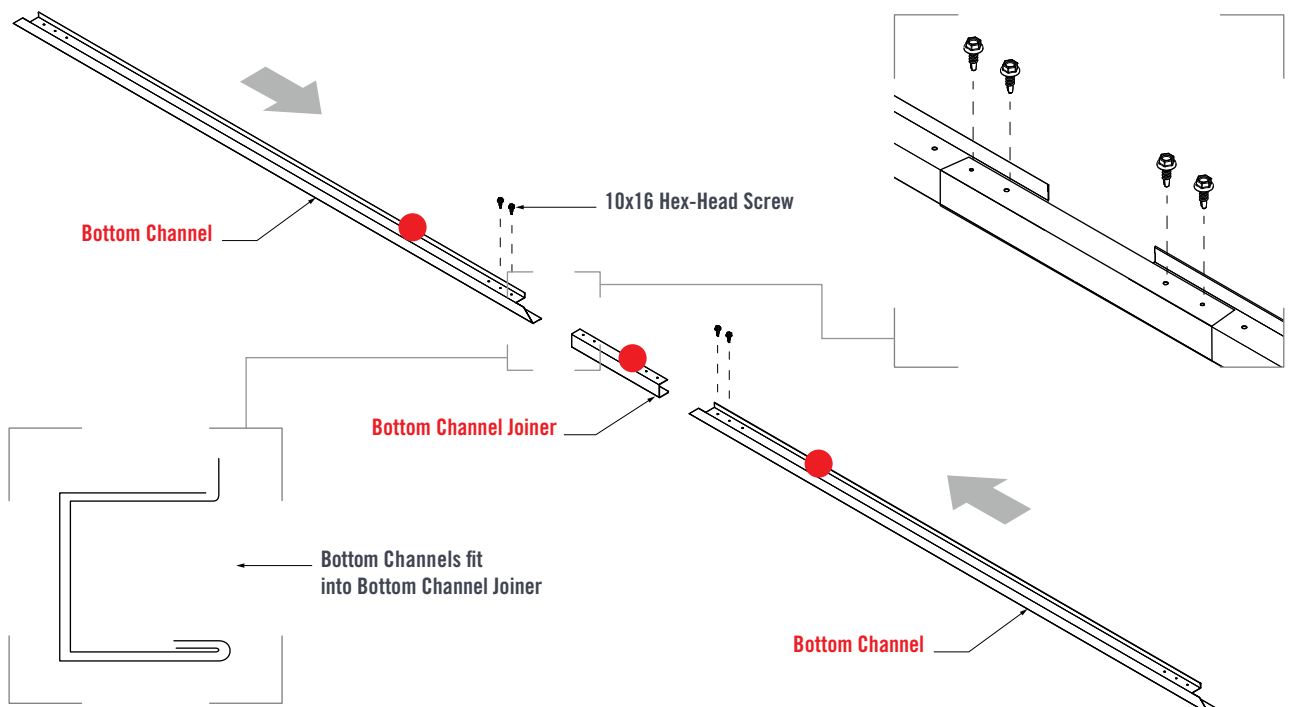

FIGURE 2.1

Slide both **Sliding Rails** over the **Sliding Rail Joiner**. Ensure the middle pre-punched holes of the **Sliding Rail Joiner** and **Sliding Rail** line up. Fasten twelve 10x16 Hex-Head Screws through the pilot holes of the **Sliding Rails** and into the **Sliding Rail Joiner** (Figure 2.2).

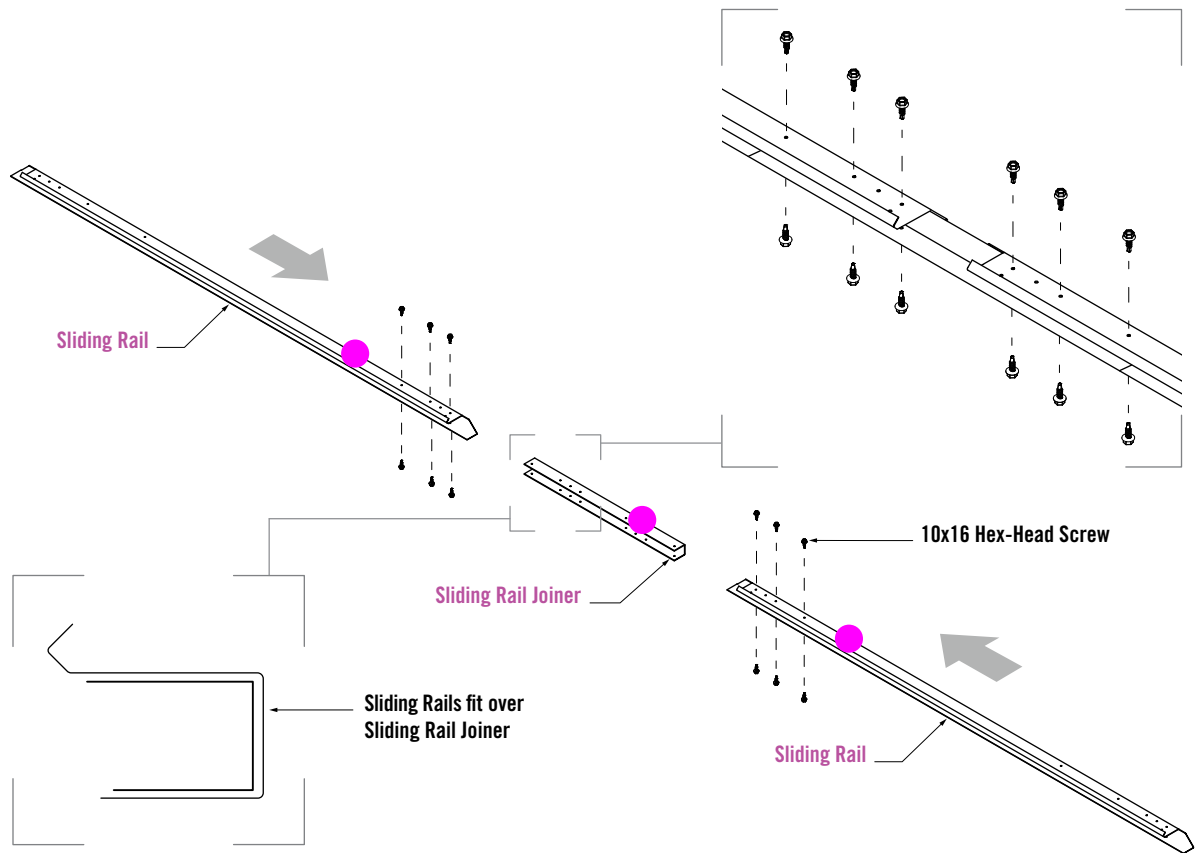

FIGURE 2.2

WALL ASSEMBLY

Stratco Handi-Mate Windows

Refer to the "Window Installation" section at the end of this document if installing a Stratco Window, or visit a Stratco store for more information.

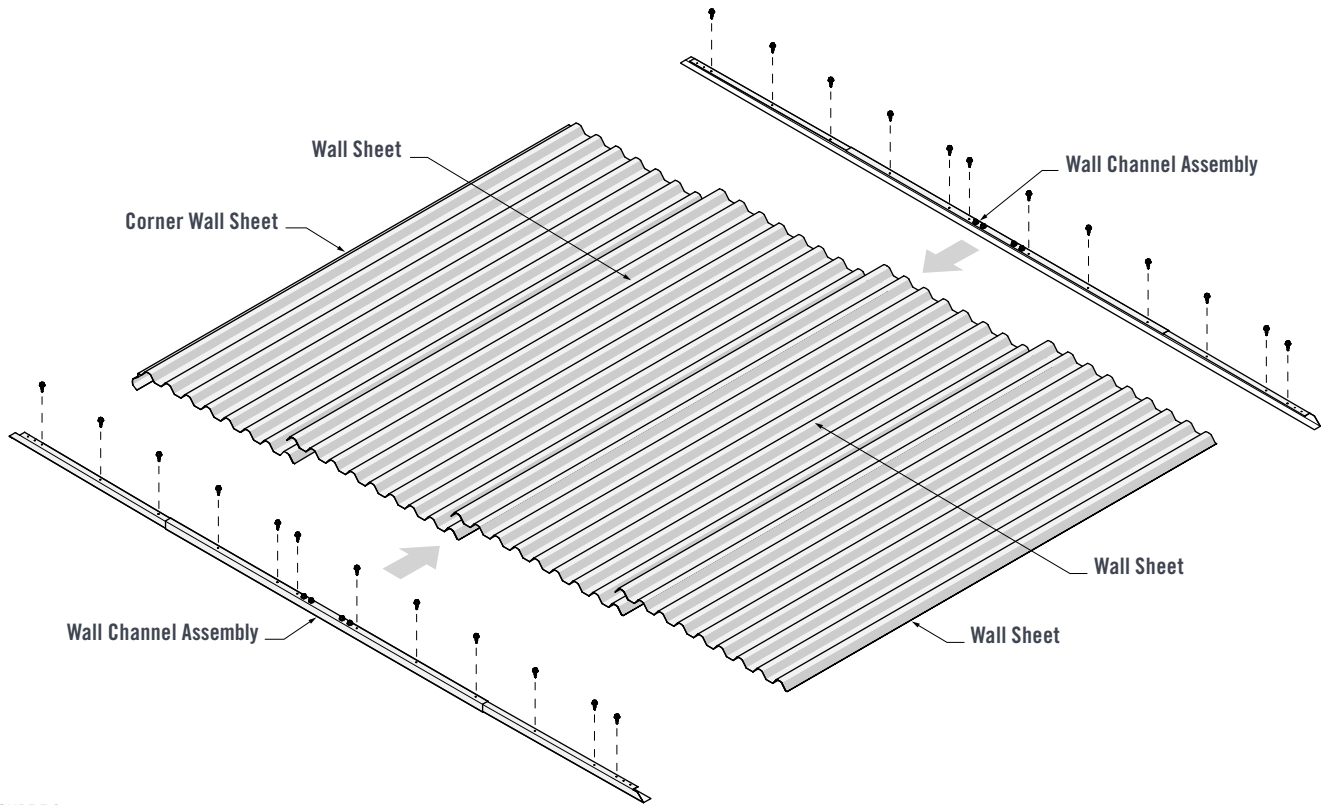

FIGURE 3.0

Using Trestles or Blocks to support the sheets, lay the Corner Wall Sheet down first. Then lay down the three Wall Sheets. Pay attention to the 'overlap' and 'underlap' lapping details (Figure 3.1).

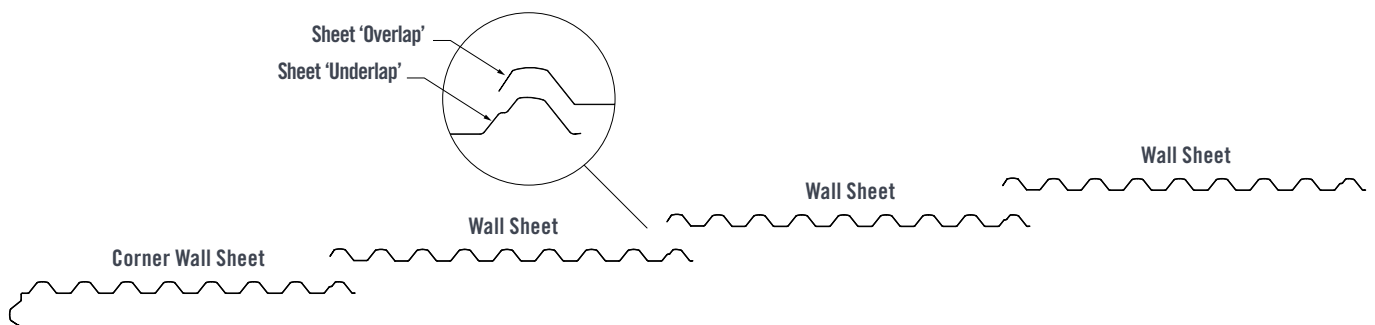

FIGURE 3.1

1. Fit the Wall Channel Assembly over the lapped Wall Sheets. The end of the Wall Channel should fit up against the end of the Corner Wall Sheet (Figure 3.2).

2. Wall Channels have three pilot holes in each end. Fasten through the third pilot hole of both Wall Channel ends and into the Wall Sheet crests. Fasten through the Wall Channel Assemblies and into every third Wall Sheet crest using ten 10x16 Hex-Head Screws in each Wall Channel Assembly (Figure 3.2).

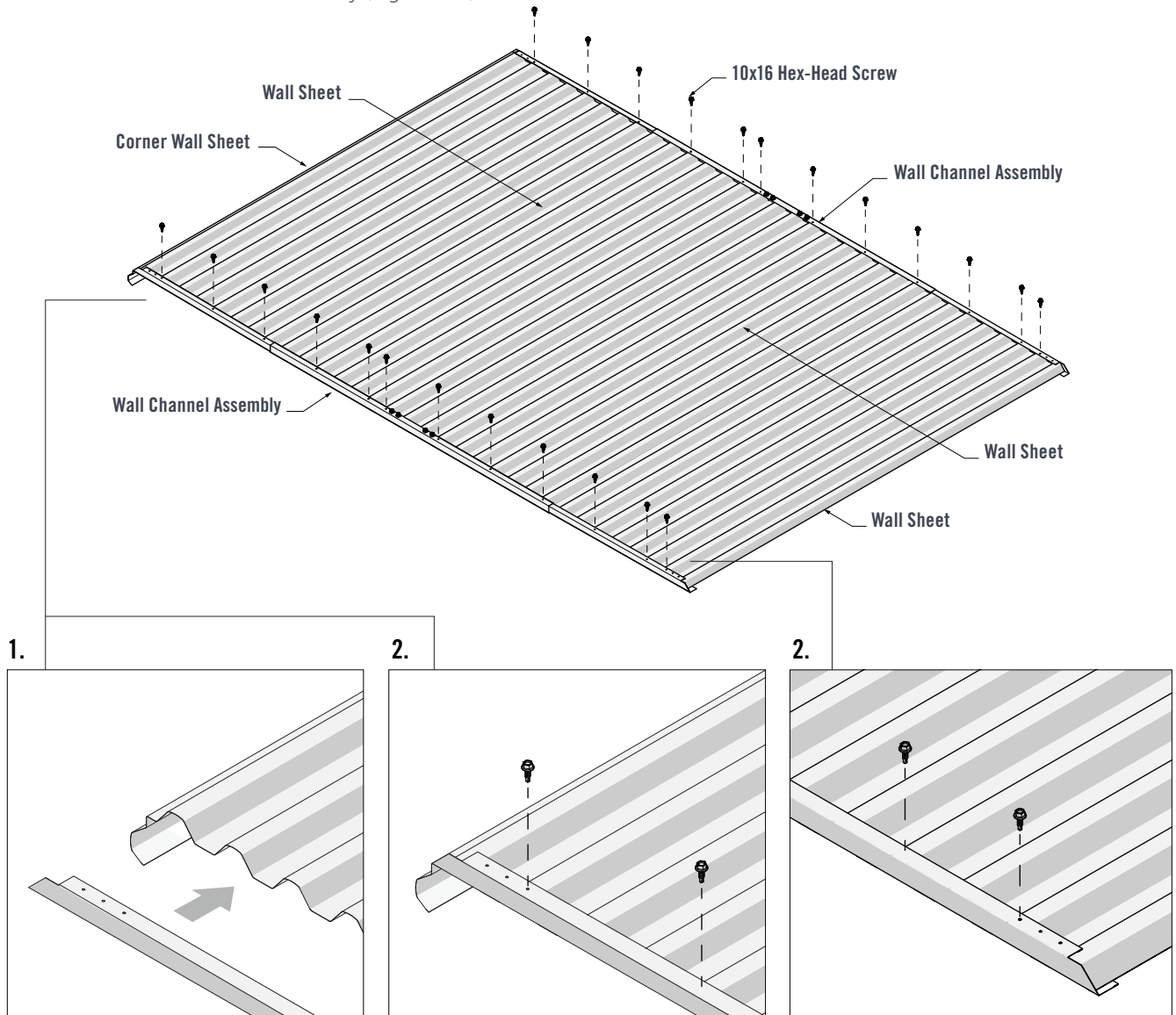

FIGURE 3.2

SIDE WALL ASSEMBLY

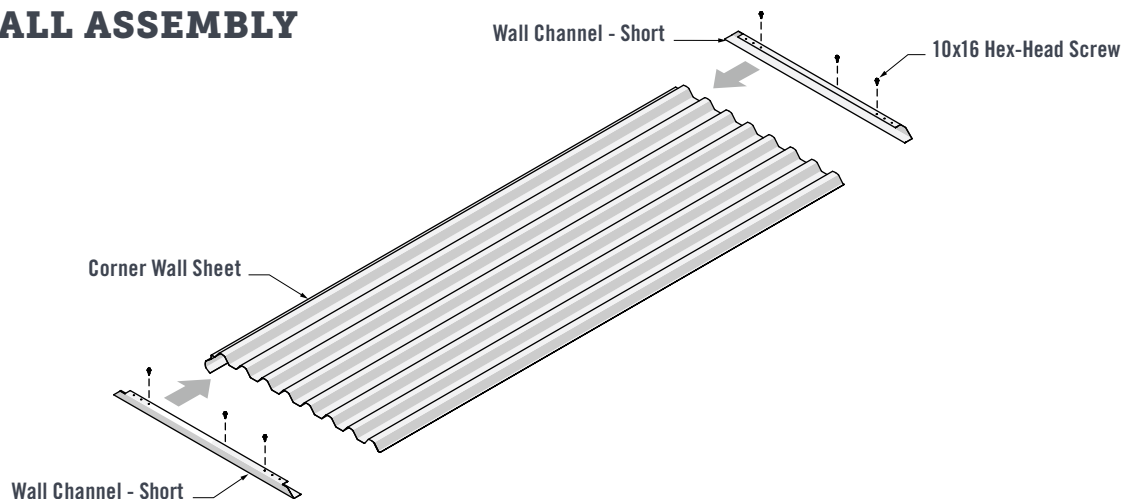

FIGURE 4.0

HANDI-MATE™ HML LOCKER SHED INSTALLATION GUIDE

Using Trestles or Blocks to support the Sheets, lay the Corner Wall Sheet down (Figure 4.1).

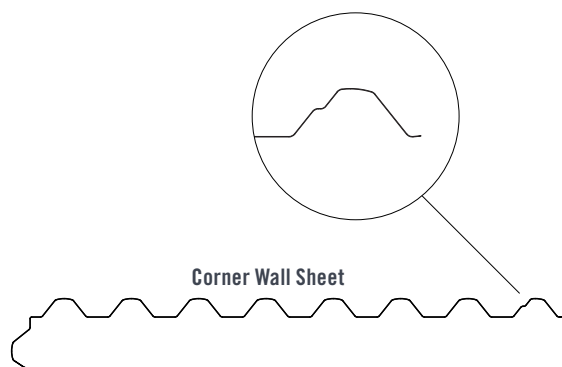

FIGURE 4.1

1. Fit the Wall Channel (Short) over the Corner Wall Sheet. The end of the Wall Channel should fit up against the end of the Corner Wall Sheet (Figure 4.2).

2. Fasten through the third pilot hole of both Wall Channel ends and into the Wall Sheet crests. Fasten through the Wall Channels and into the third Wall Sheet crest using one 10x16 Hex-Head Screw in each Wall Channel (Figure 4.2).

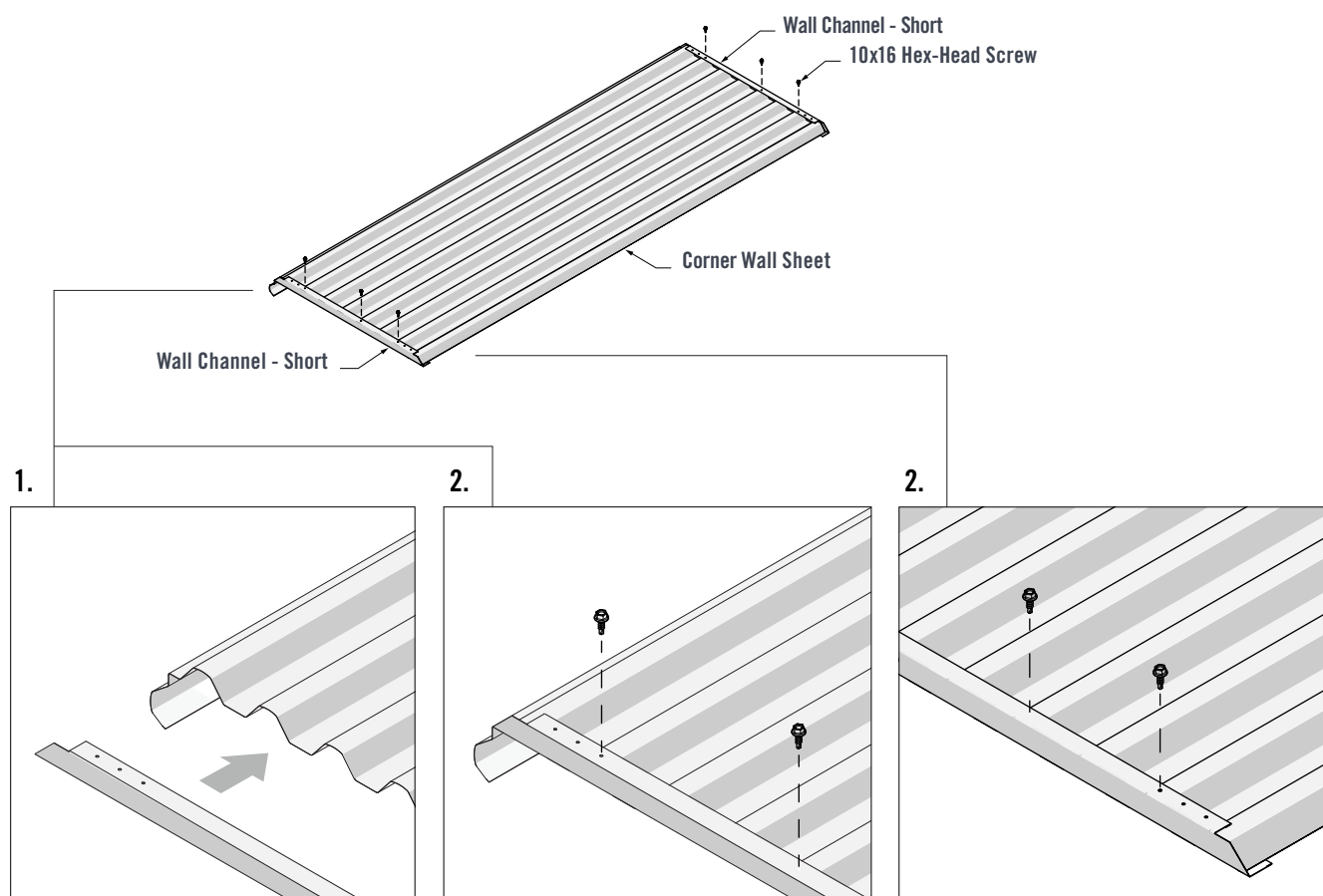

FIGURE 4.2

SECOND SIDE WALL ASSEMBLY

Repeat steps in Figures 4.0 - 4.2 to make a second Side Wall Assembly.

FRONT WALL ASSEMBLY

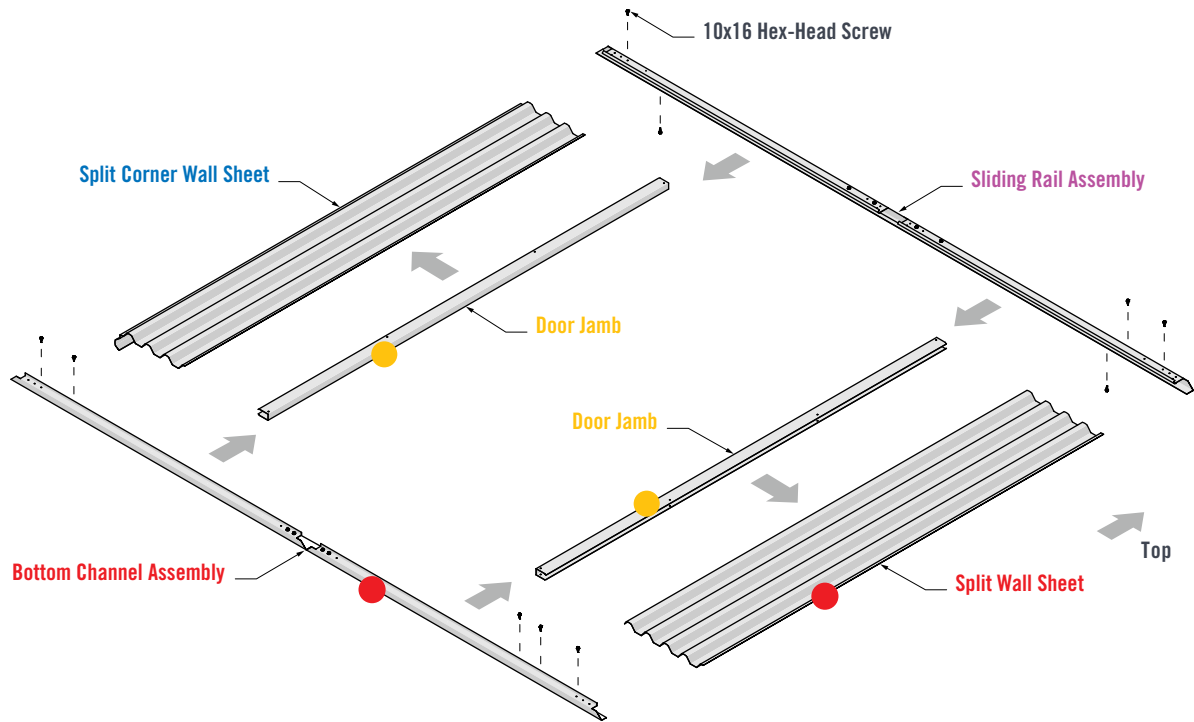

FIGURE 5.0

Using Trestles or Blocks to support the Sheets, lay down the **Split Corner Wall Sheet** and **Split Wall Sheet** (Figure 5.1).

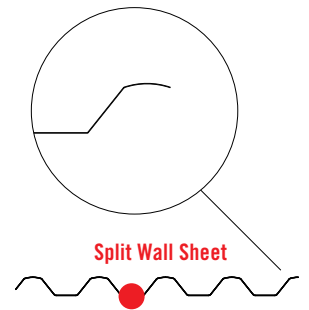
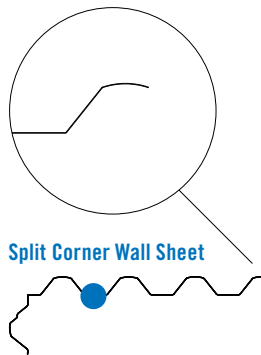

FIGURE 5.1

HANDI-MATE™ HML LOCKER SHED INSTALLATION GUIDE

1. Fit the **Bottom Channel Assembly** and **Sliding Rail Assembly** over the Wall Sheets. The end of the Channels should fit up against the ends of the **Split Corner Wall Sheet** (Figure 5.2).
2. Fasten one 10x16 self-drilling screw through the third pilot hole of the **Bottom Channel** and into the corresponding Wall Sheet crest at both ends. Fasten another 10x16 self-drilling screw through the third pilot hole of the **Sliding Rail** and into the corresponding Wall Sheet crest at both ends (Figure 5.2).

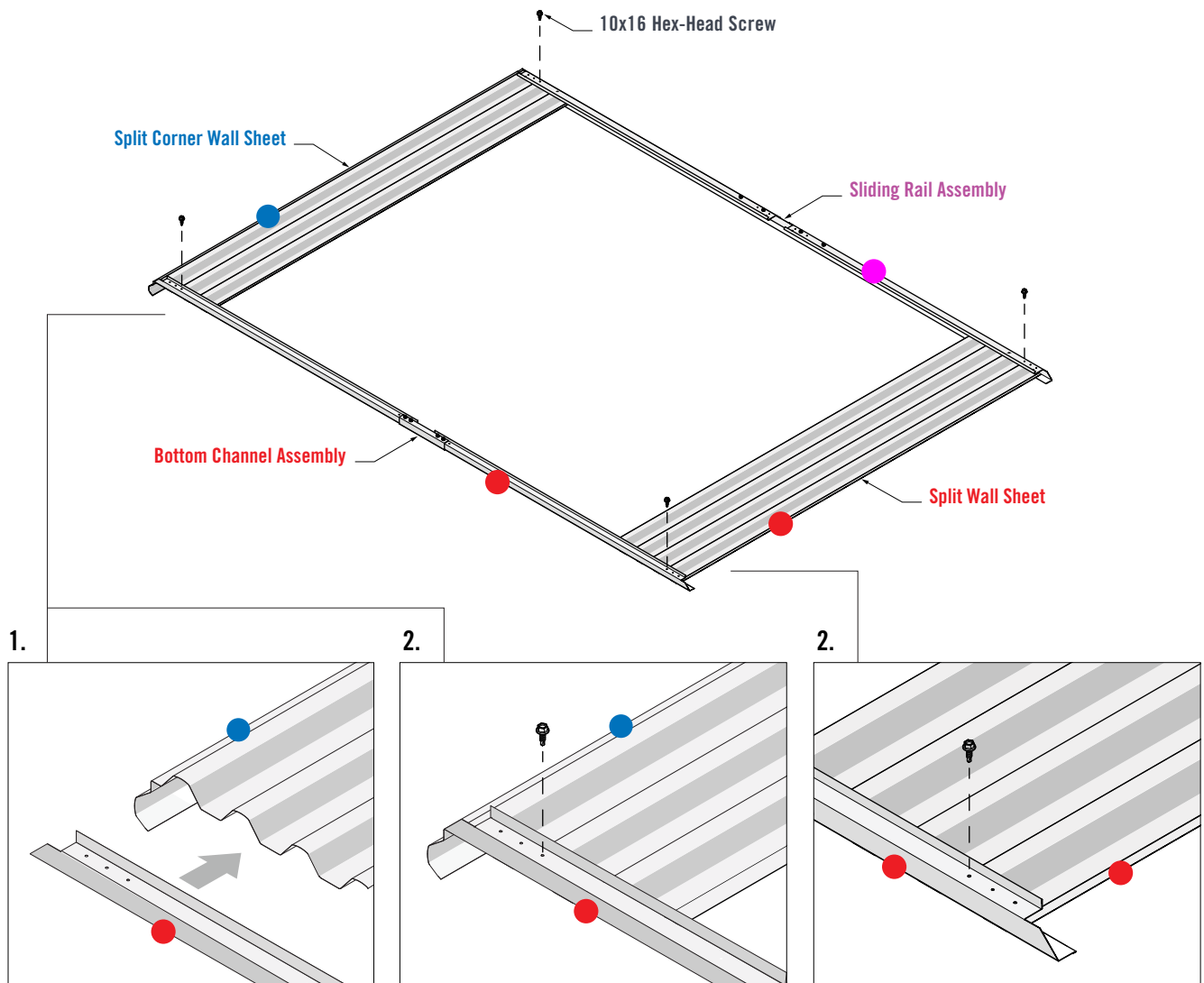

FIGURE 5.2

1. Fit the **Door Jambs** into the **Bottom Channel Assembly** and **Sliding Rail Assembly**. Position the **Door Jambs** over the Wall Sheets. Set the correct spacing of the **Door Jambs** using the **Door Shroud** as a guide. Fasten two 10x16 Hex-Head Screws through pilot holes in the **Door Jambs** and into to the Wall Sheets (Figure 5.3).
2. Fasten both **Door Jambs** to the Channel Assemblies with four 10x16 Hex-Head Screws (Figure 5.3).

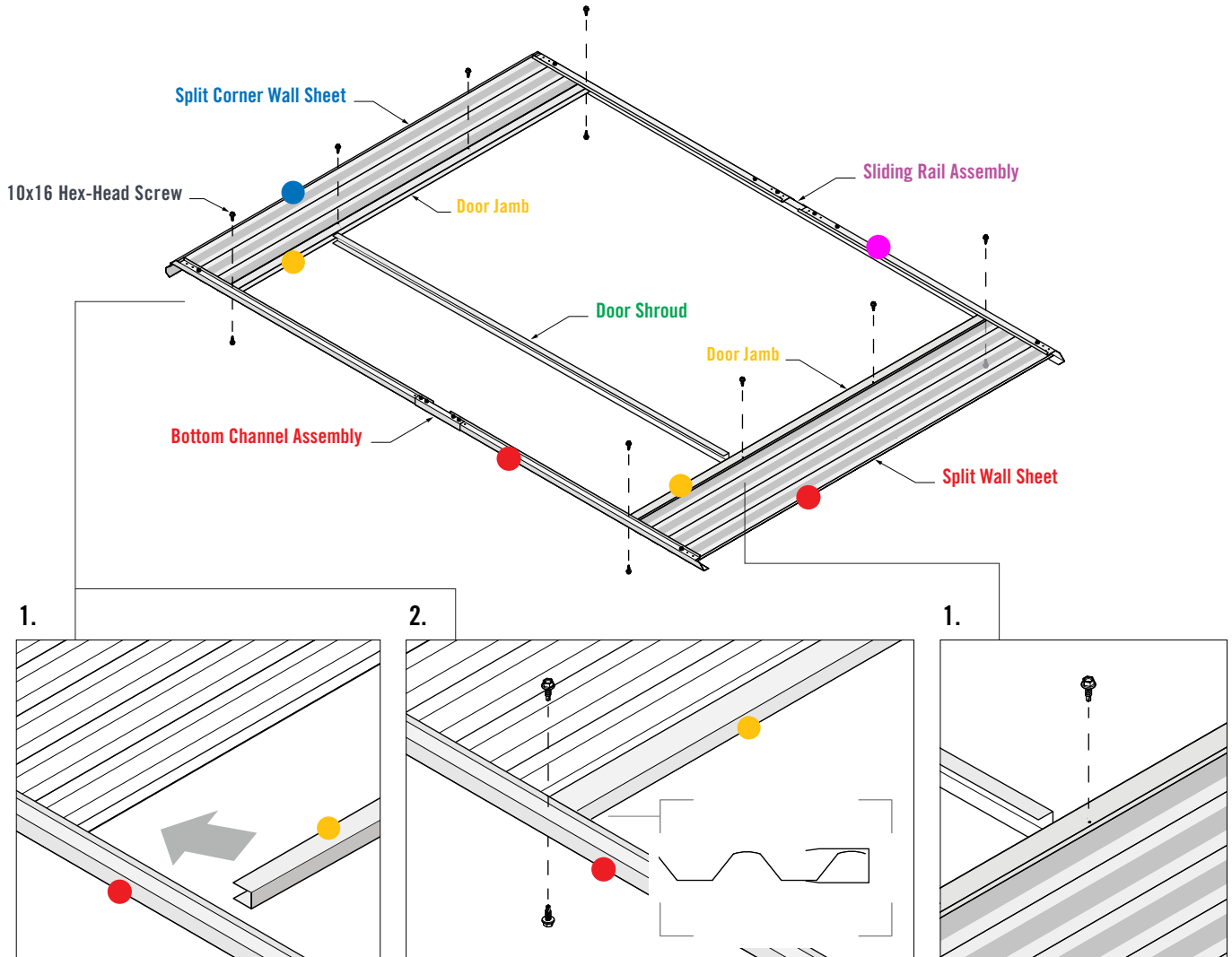

FIGURE 5.3

DOOR ASSEMBLY - LEFT

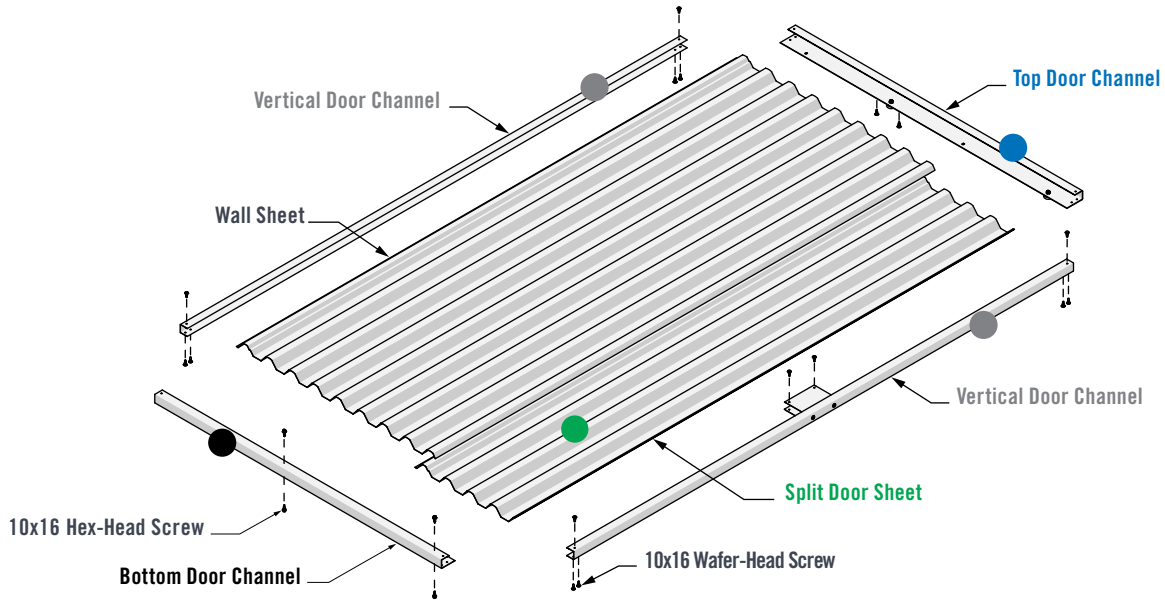

FIGURE 6.0

Fix the two Door Wheels to the **Top Door Channel** using Door Nuts (Figure 6.1).

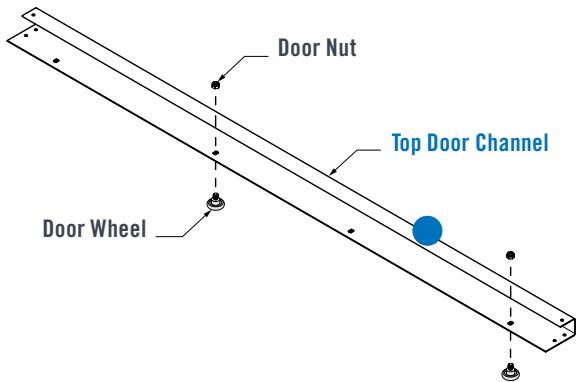

FIGURE 6.1

Fit the two Handle Mounts into the Vertical Door Channel (Figure 6.2). The two Handle Mounts are the same component, so can be installed in either order.

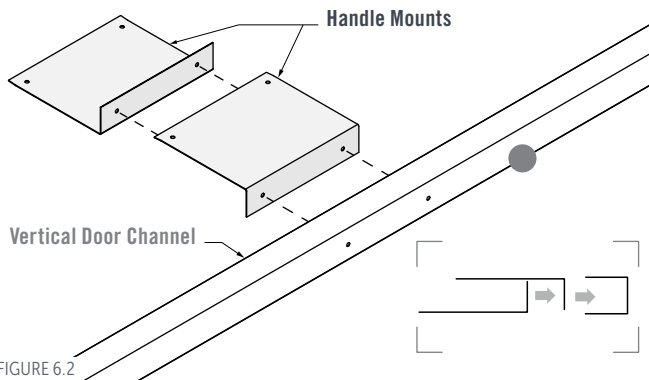

FIGURE 6.2

Fasten two 10x16 Wafer-Head Screws through the Vertical Door Channel and into the Handle Mounts (Figure 6.3).

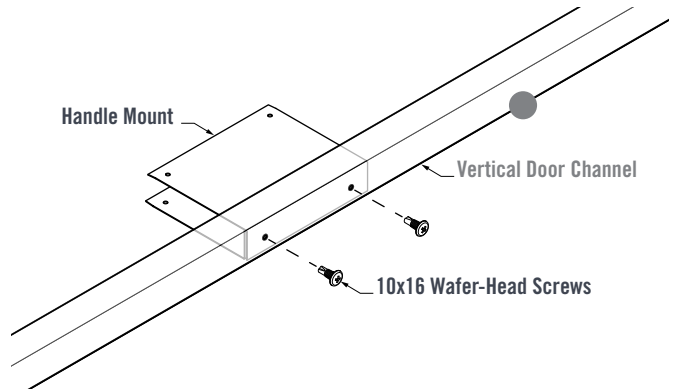

FIGURE 6.3

Using Trestles or Blocks to support the Sheets, lay down the **Split Door Sheet** and Wall Sheet. Pay attention to lapping details (Figure 6.4).

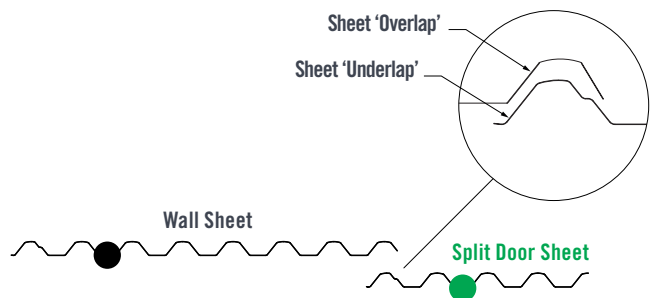

FIGURE 6.4

1. Fit the Vertical Door Channels over the side of the door sheets, then fit the **Top** and **Bottom Door Channels** over the door sheet ends. Ensure the lip of the **Top** and **Bottom Door Channels** fit over the **Vertical Door Channels** (Figure 6.5).
2. Fasten one 10x16 Wafer-Head Screw through the pilot holes in the corner of each **Top** & **Bottom Channel** and into the **Vertical Door Channels** (Figure 6.5).
3. Crest-fix two 10x16 Wafer-Head Screws through the pilot holes in the **Handle Mount** and into the **Split Door Sheet** (Figure 6.5).

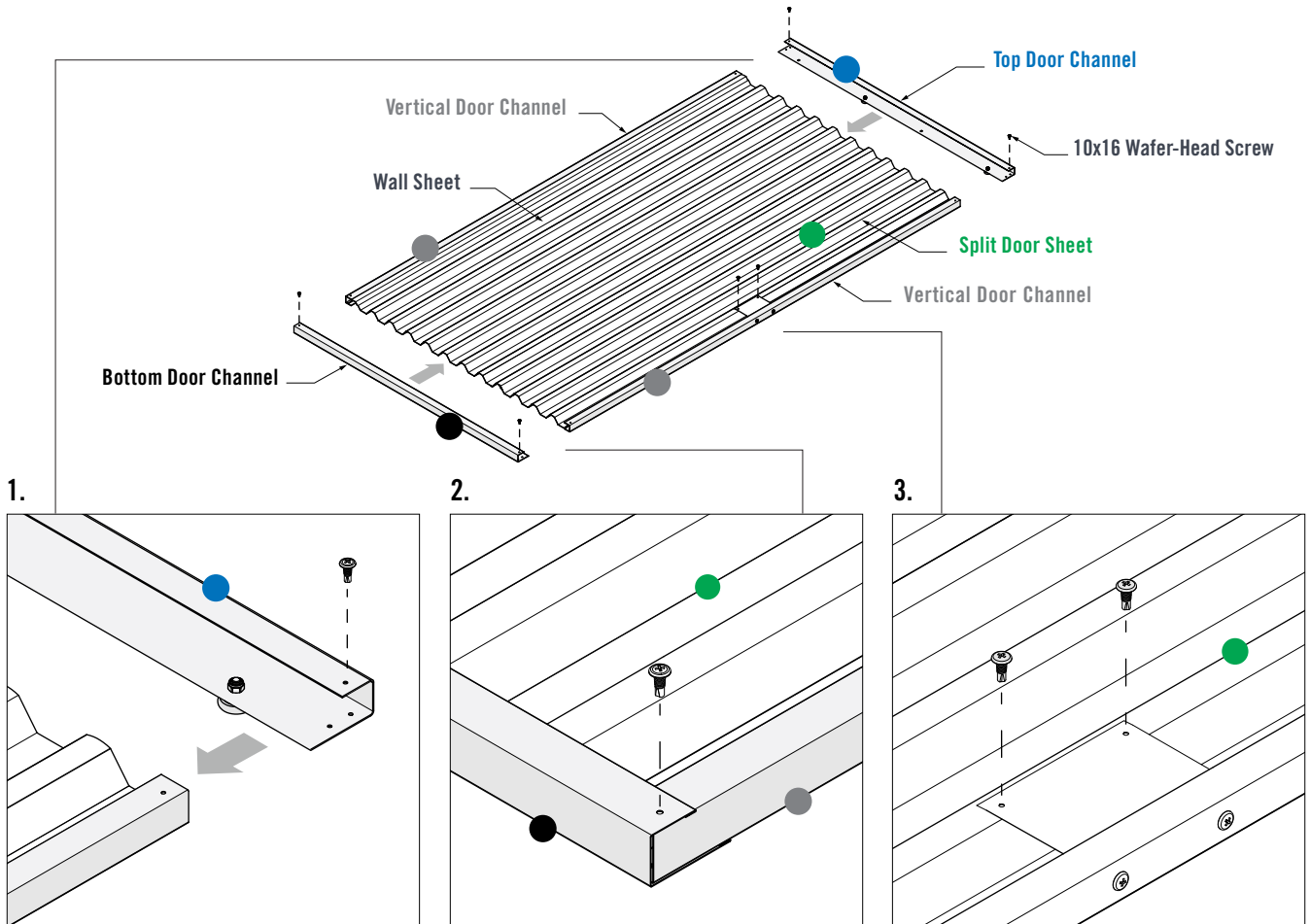

FIGURE 6.5

HANDI-MATE™ HML LOCKER SHED INSTALLATION GUIDE

1. Fasten a 10x16 Hex-Head Screw into the mid-point of the Bottom Door Channel. Ensure the screw is fastened approximately 10mm from the bottom face of the Channel. Fasten a 10x16 Hex-Head Screw near the Handle Mount end of the Bottom Door Channel. Flip over the Door Assembly so that the underside is now facing up. Fasten two more 10x16 Hex-Head Screws in the same manner on the opposite side of the Bottom Door Channel (Figure 6.6).
2. Fasten two 10x16 Wafer-Head Screws through pilot holes in the Top and Bottom Door Channels and into the Vertical Door Channels at all four corners (Figure 6.6).
3. Fasten a 10x16 Wafer-Head Screw through the Top Door Channel and into the two Sheet Crests on both sides of the Door Wheel (Figure 6.6).

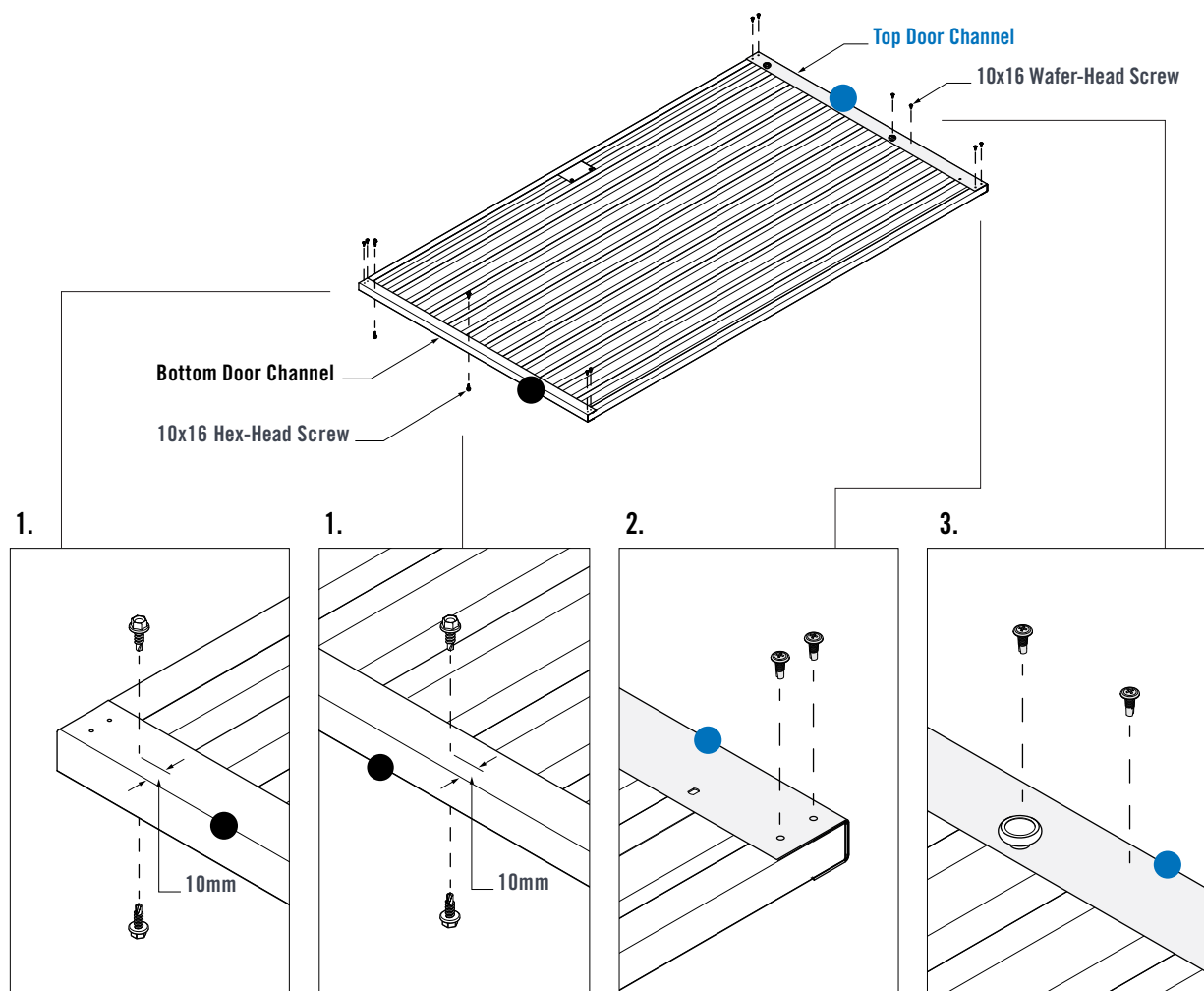

FIGURE 6.6

DOOR ASSEMBLY - RIGHT

The Door Assembly - Right is a mirrored copy of the Door Assembly - Left.

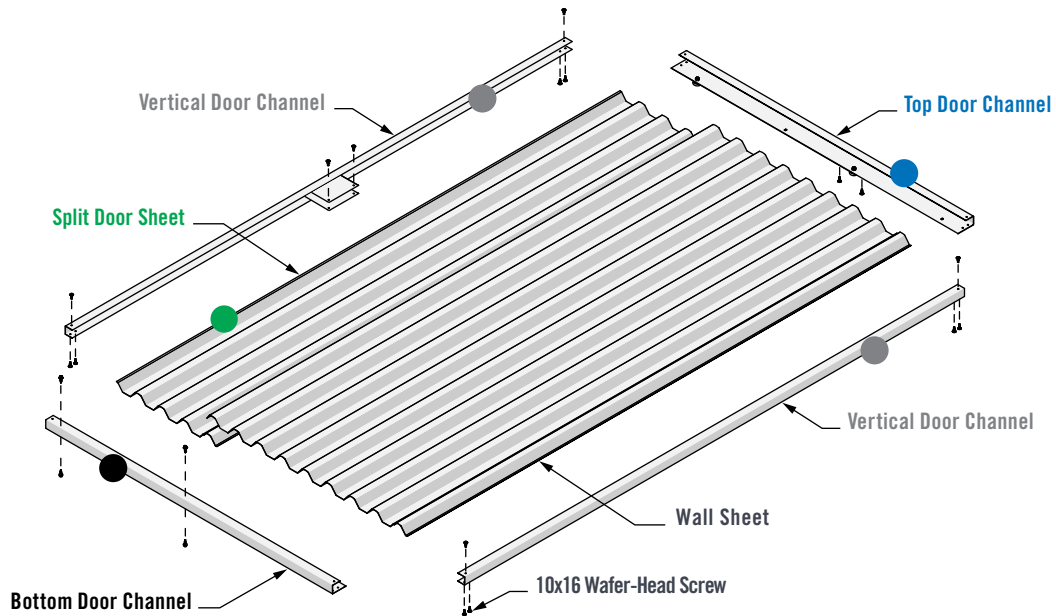

FIGURE 7.0

Fix the two Door Wheels to the **Top Door Channel** using the two Door Nuts (Figure 7.1).

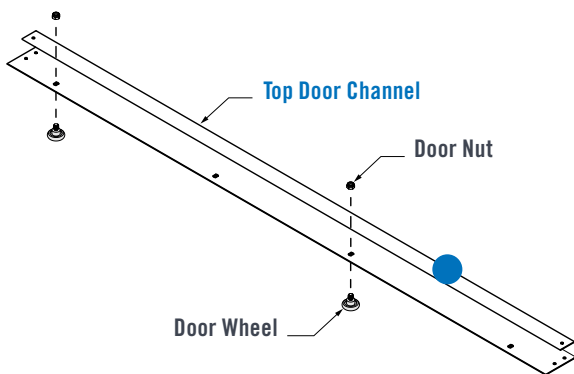

FIGURE 7.1

Fit the two Handle Mounts into the Vertical Door Channel (Figure 7.2). The two Handle Mounts are the same component, so can be installed in either order.

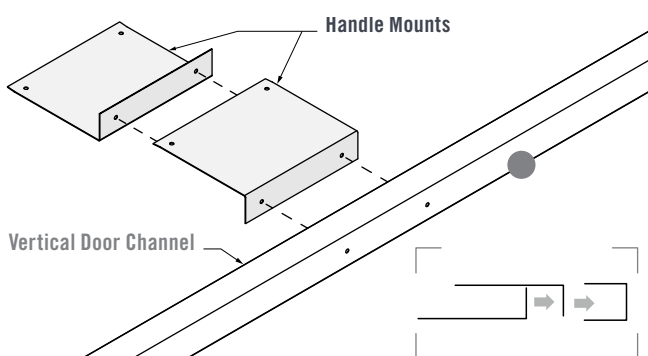

FIGURE 7.2

Fasten two 10x16 Wafer-Head Screws through the Vertical Door Channel and into the Handle Mounts (Figure 7.3).

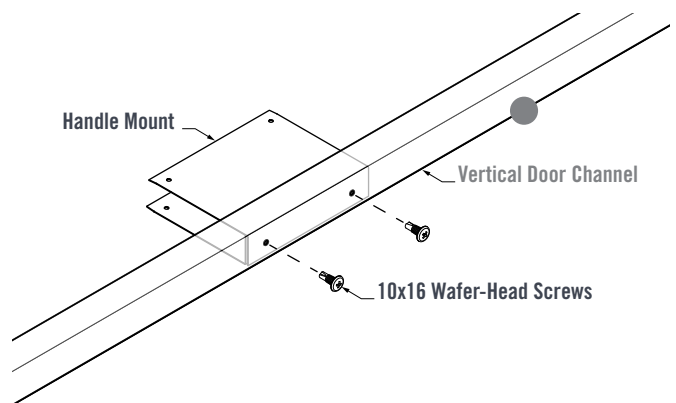

FIGURE 7.3

Using Trestles or Blocks to support the Sheets, lay down the **Split Door Sheet** and Wall Sheet. Pay attention to lapping details (Figure 7.4).

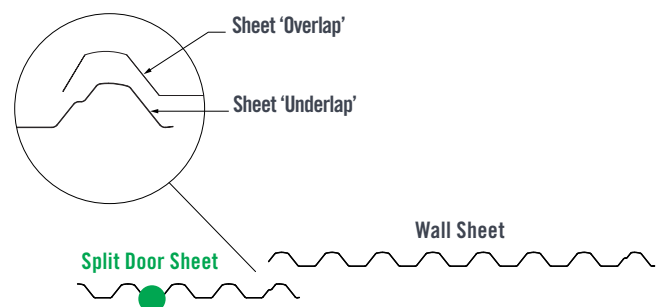

FIGURE 7.4

HANDI-MATE™ HML LOCKER SHED INSTALLATION GUIDE

1. Fit the Vertical Door Channels over the side of the door sheets, then fit the **Top** and **Bottom Door Channels** over the door sheet ends. Ensure the lip of the **Top** and **Bottom Door Channels** fit over the **Vertical Door Channels** (Figure 7.5).
2. Fasten one 10x16 Wafer-Head Screw through the pilot holes in the corner of each **Top** & **Bottom Channel** and into the **Vertical Door Channels** (Figure 7.5).
3. Crest-fix two 10x16 Wafer-Head Screws through the pilot holes in the **Handle Mount** and into the **Split Door Sheet** (Figure 7.5).

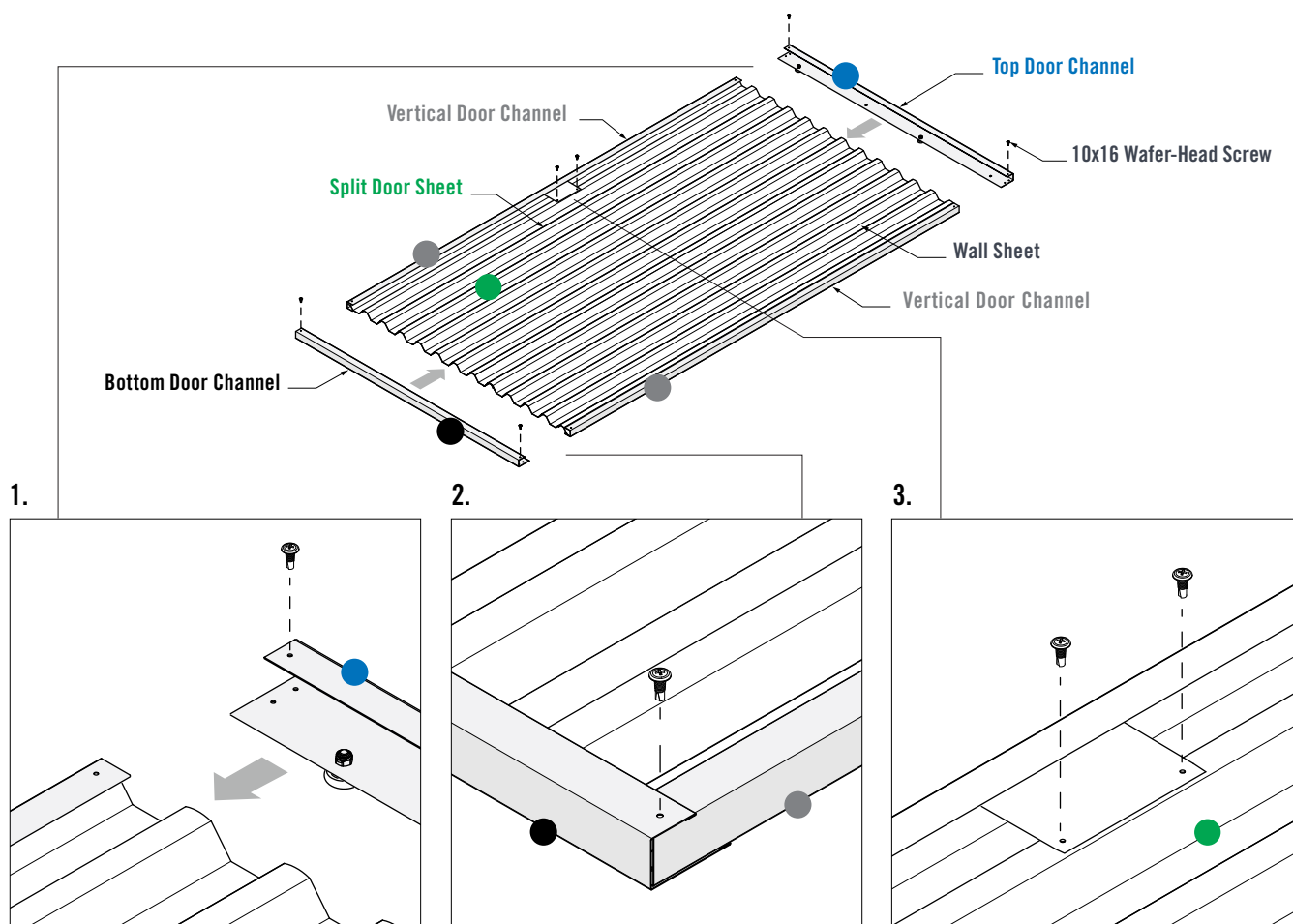

FIGURE 7.5

1. Fasten a 10x16 Hex-Head Screw into the mid-point of the Bottom Door Channel. Ensure the screw is fastened approximately 10mm from the bottom face of the Channel. Fasten a 10x16 Hex-Head Screw near the Handle Mount end of the Bottom Door Channel. Flip over the Door Assembly so that the underside is now facing up. Fasten two more 10x16 Hex-Head Screws in the same manner on the opposite side of the Bottom Door Channel (Figure 7.6).
2. Using the holes in the Handle Mounts as a guide, drill a $\varnothing 3.5$ mm pilot hole, then $\varnothing 12$ mm hole through the Wall Sheet (Figure 7.6).
3. Fasten two 10x16 Wafer-Head Screws through pilot holes in the Top and Bottom Door Channels and into the Vertical Door Channels at all four corners (Figure 7.6).
4. Fasten a 10x16 Wafer-Head Screw through the Top Door Channel and into the two Sheet Crests on both sides of the Door Wheel.

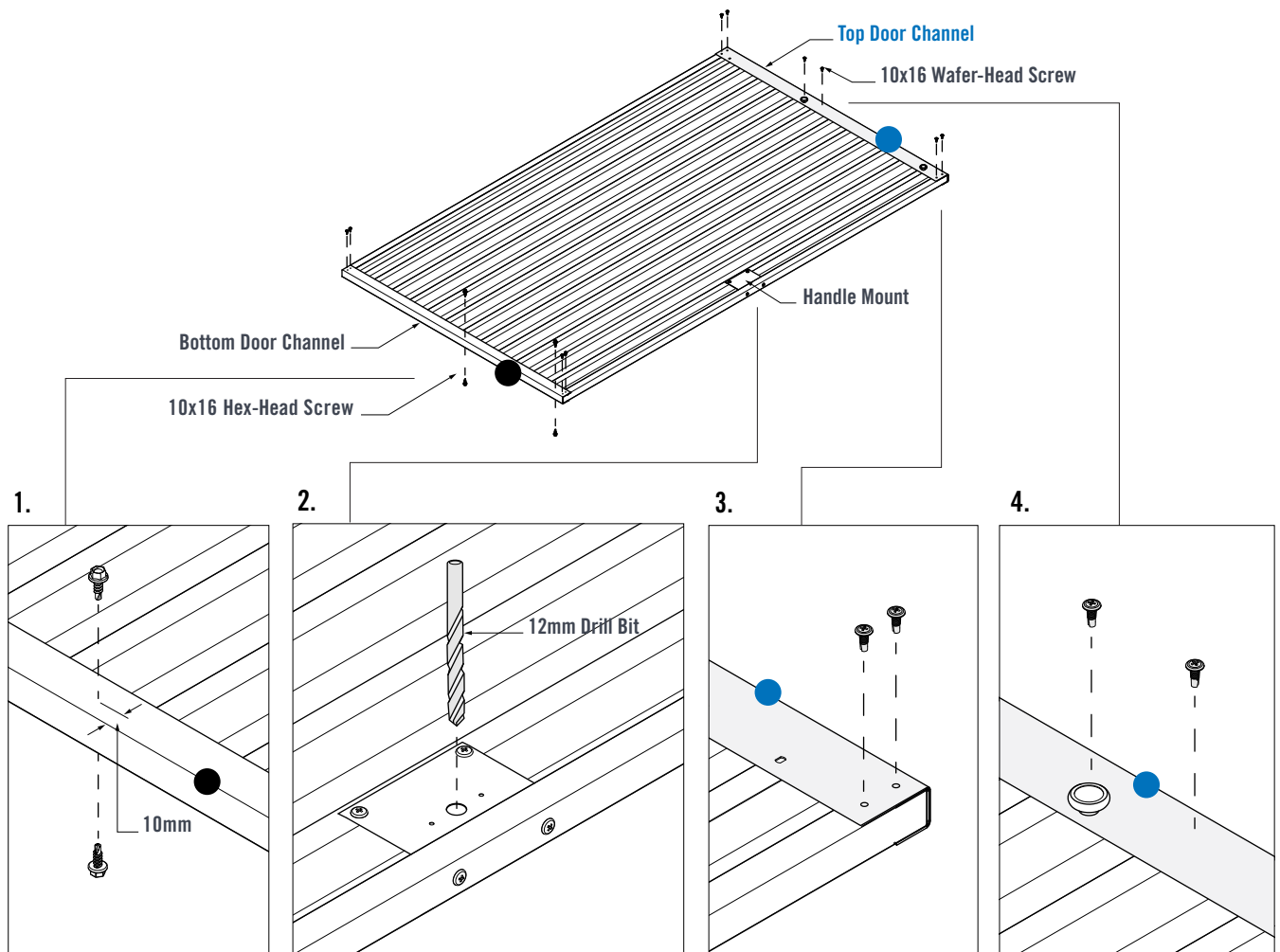

FIGURE 7.6

JOINING WALL ASSEMBLIES

The wall assemblies can now be joined together. Fit the Split [Corner Wall Sheet](#) of the Front Wall over the Side Wall Sheet. Ensure the Corner Sheet fits inside the Side Wall Channels.

1. Fit a Corner Bracket over the top Channels. Ensure the pilot holes of the Corner Bracket and Channels line up (Figure 8.0).
2. Fasten through the Corner Bracket pilot holes and into the top Channels using four 10x16 Hex-Head Screws (Figure 8.0).
3. Fit a Corner Bracket to the bottom Wall Channels. Fasten through the Corner Bracket pilot holes and into the bottom Wall Channels using four 10x16 Hex-Head Screws (Figure 8.0).

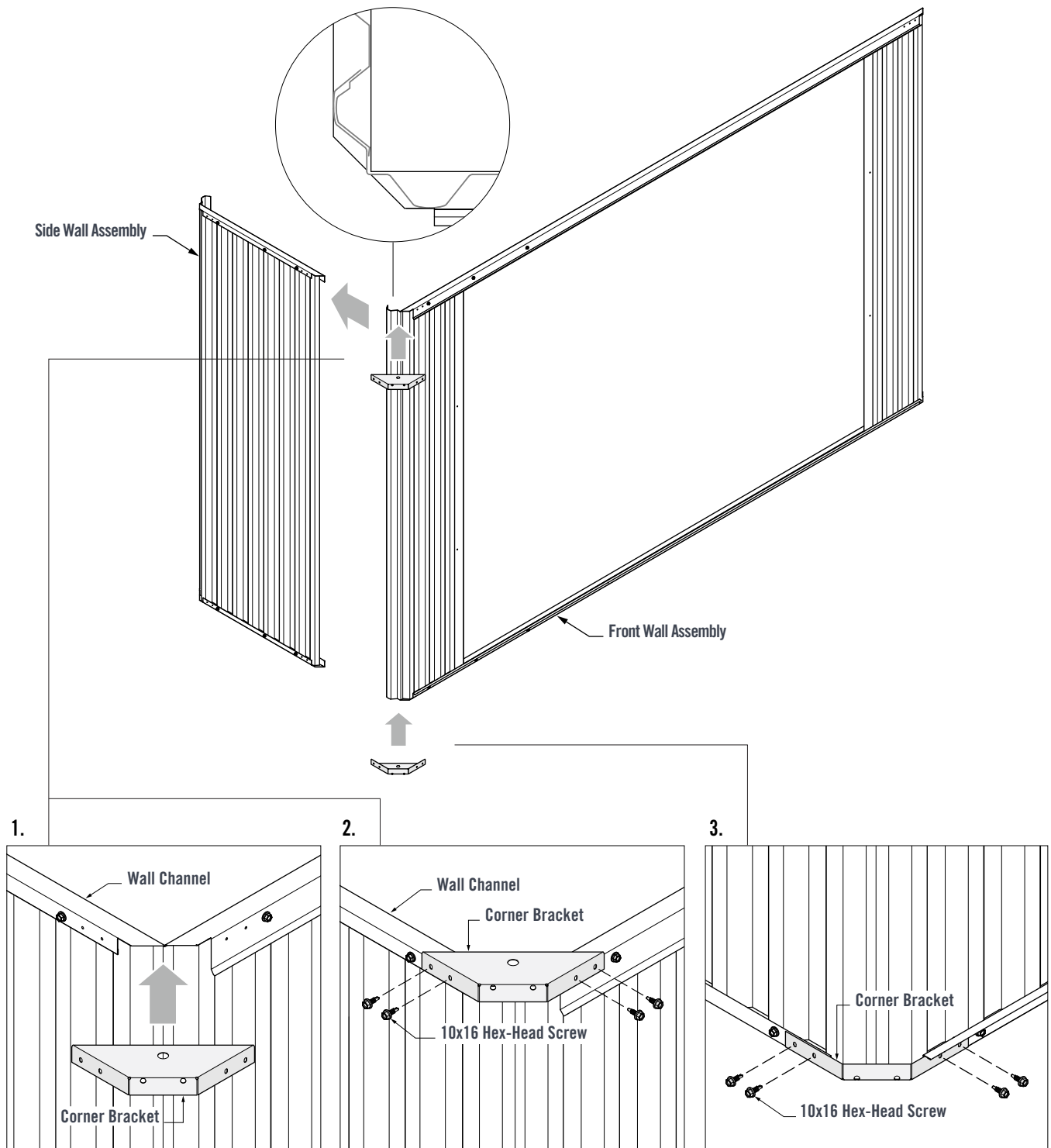

FIGURE 8.0

Fit the Remaining Wall Assemblies together with Corner Brackets as per Figure 8.0.

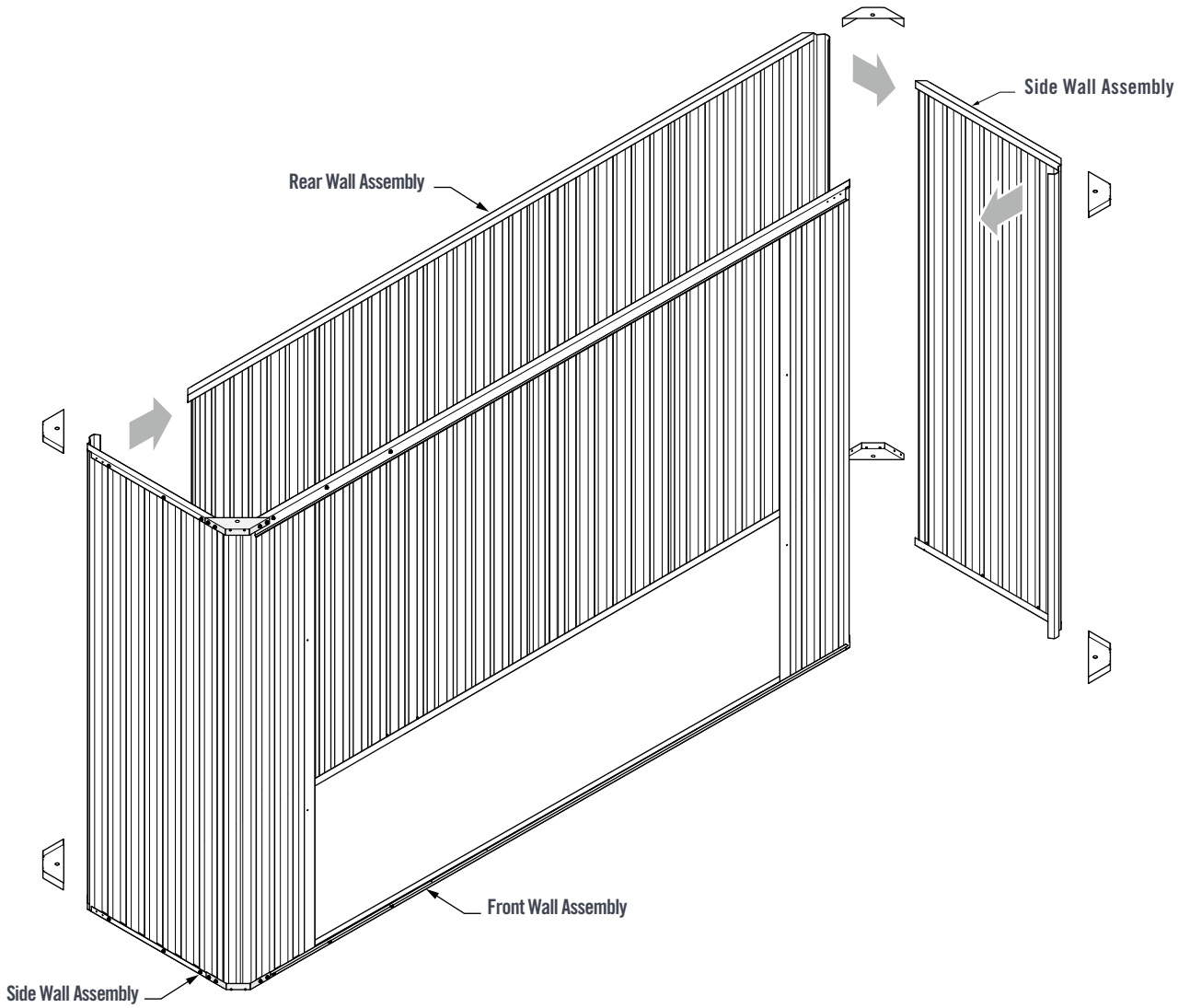

FIGURE 8.1

HANDI-MATE™ HML LOCKER SHED INSTALLATION GUIDE

1. Fit the two Barge Supports over the **Sliding Rail Assembly**. Fasten six 10x16 Hex-Head Screws through the pilot holes of the Barge Supports and into the **Sliding Rail Assembly** (Figure 8.2).
2. Fit the two Runner Rails over the **Bottom Channel Assembly**. Fasten six 10x16 Hex-Head Screws through the pilot holes of both Runner Rails and into the **Bottom Channel Assembly** (Figure 8.2).

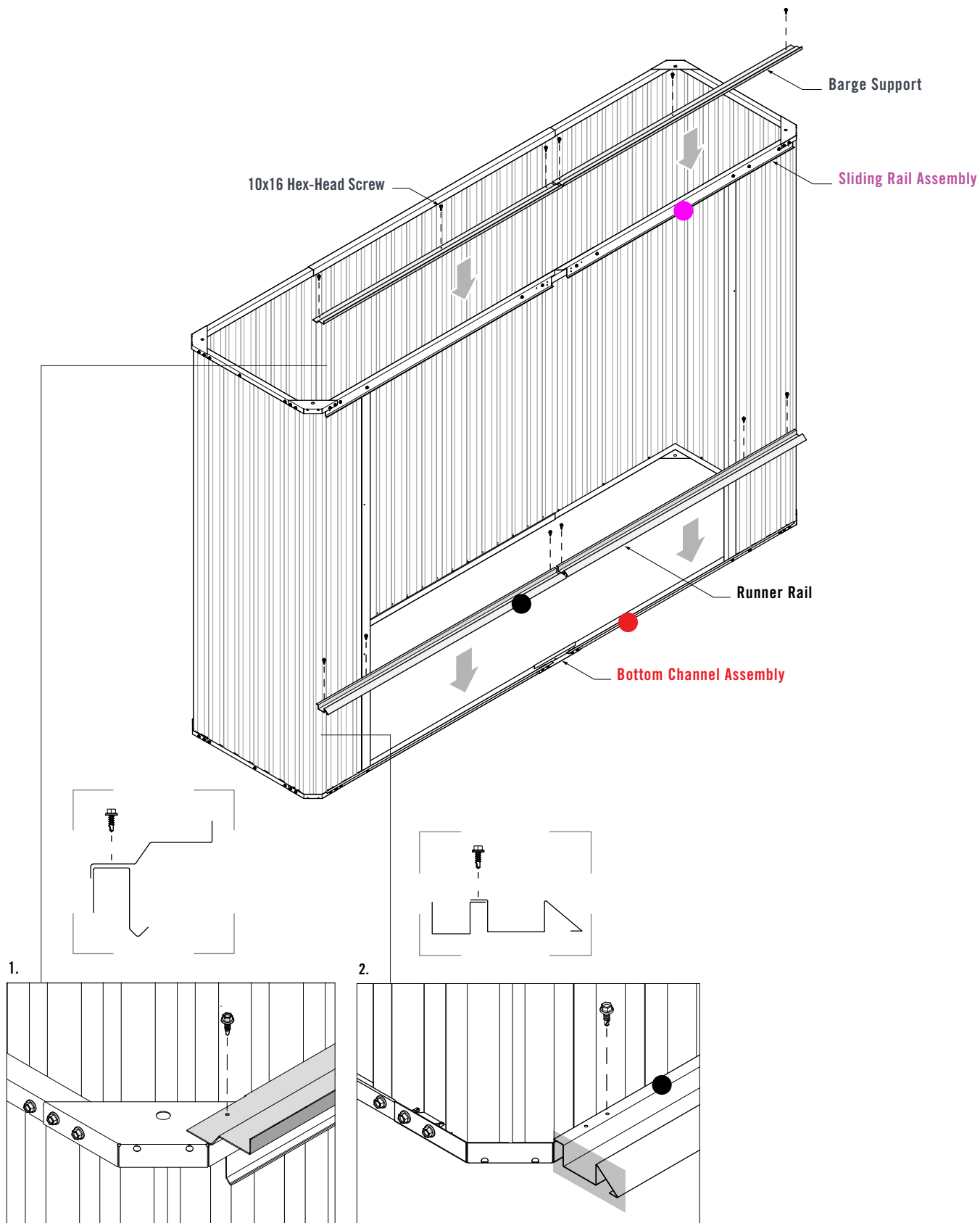

FIGURE 8.2

Check the walls are square. Check the diagonal measurements from corner to corner (dashed lines, Figure 8.3). The diagonal measurements should be equal for the walls to be square.

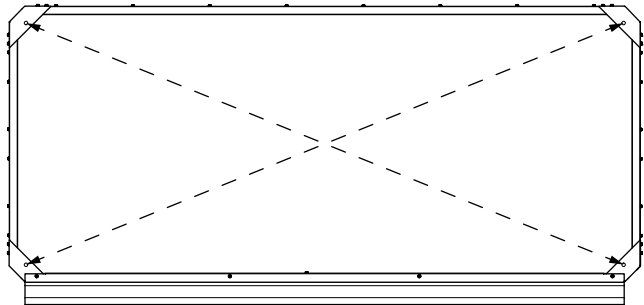

FIGURE 8.3

Note: Shed anchoring requirements are determined by the wind zone the Handi-Mate is installed in. Contact a Stratco store for further information or to determine your wind zone.

The recommended anchor spacing in Figure 8.4 below, where anchor points are no greater than 900mm apart, will satisfy engineering requirements for N1, N2 and N3 wind zones.

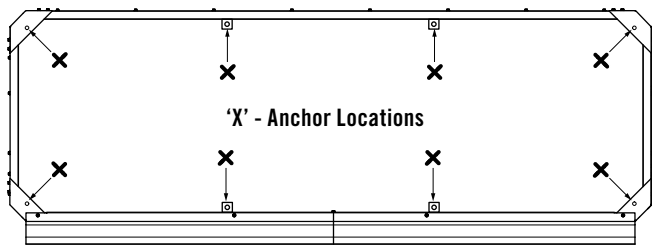

FIGURE 8.4

Using the Corner Bracket pilot holes as a guide, drill holes in all four corners with a 10mm masonry drill bit. Secure all four bottom Corner Brackets to the concrete base with M8x47 Masonry Anchors (Figure 7.5).

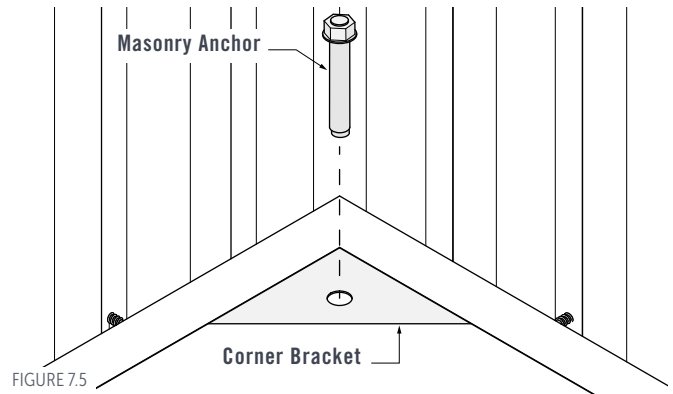

FIGURE 7.5

Fit a Hold Down Lug at the middle of both Long Wall Channels. Fasten one 10x16 Hex-Head Screw through each Hold Down Lug into the Wall Channel and Wall Sheet. Fix both Hold Down Lugs to the concrete base with M8x47 Masonry Anchors (Figure 7.6).

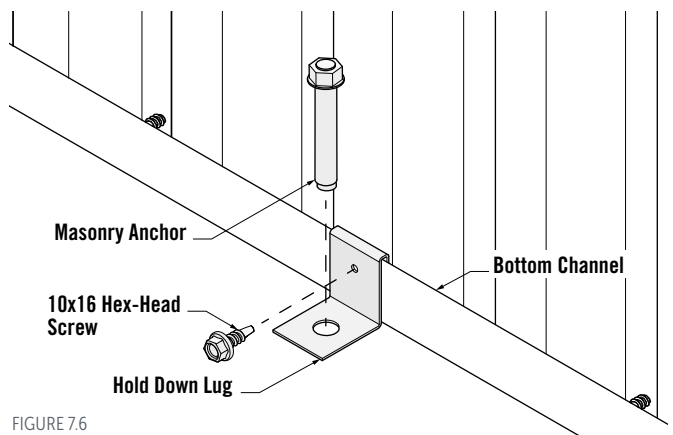

FIGURE 7.6

ROOF ASSEMBLY

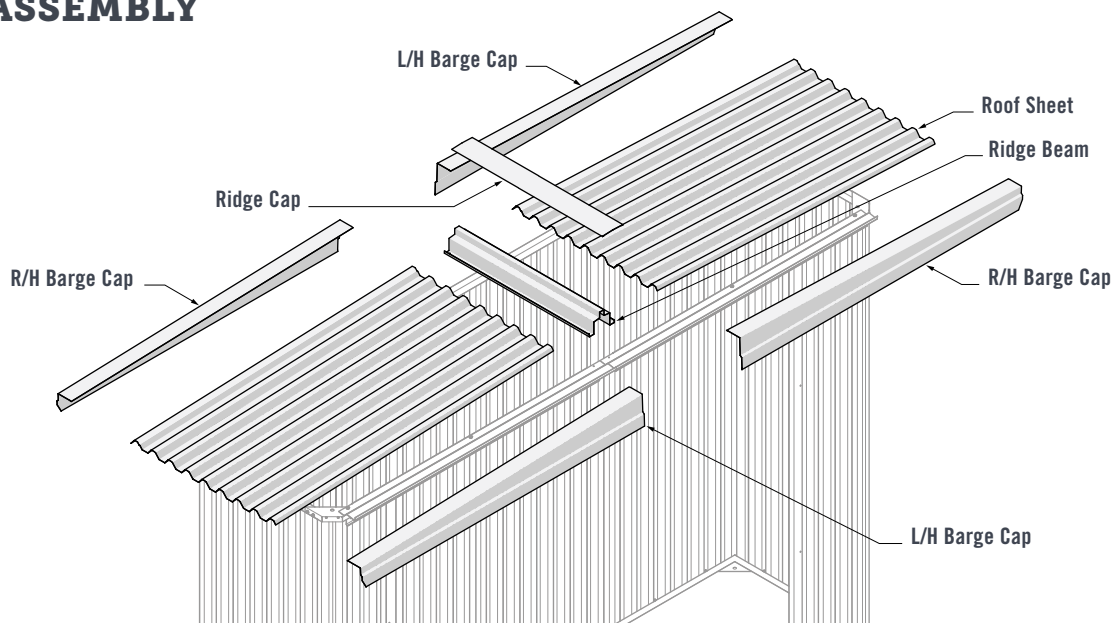

FIGURE 8.0

HANDI-MATE™ HML LOCKER SHED INSTALLATION GUIDE

Fit the Ridge Beam onto the top Wall Channel Assembly and Barge Support. Ensure 1355mm spacing between the edge of the shed and edge of the Ridge Beam (Figure 8.1).

1. Align the end of the Ridge Beam with the step of the Barge Support. Fasten two 10x16 Hex-Head Screws through the pilot holes in the Ridge Beam and into the Barge Support (Figure 8.1).

2. Fasten two 10x16 Hex-Head Screws through the pilot holes in the Ridge Beam and into the rear Wall Channel Assembly (Figure 8.1).

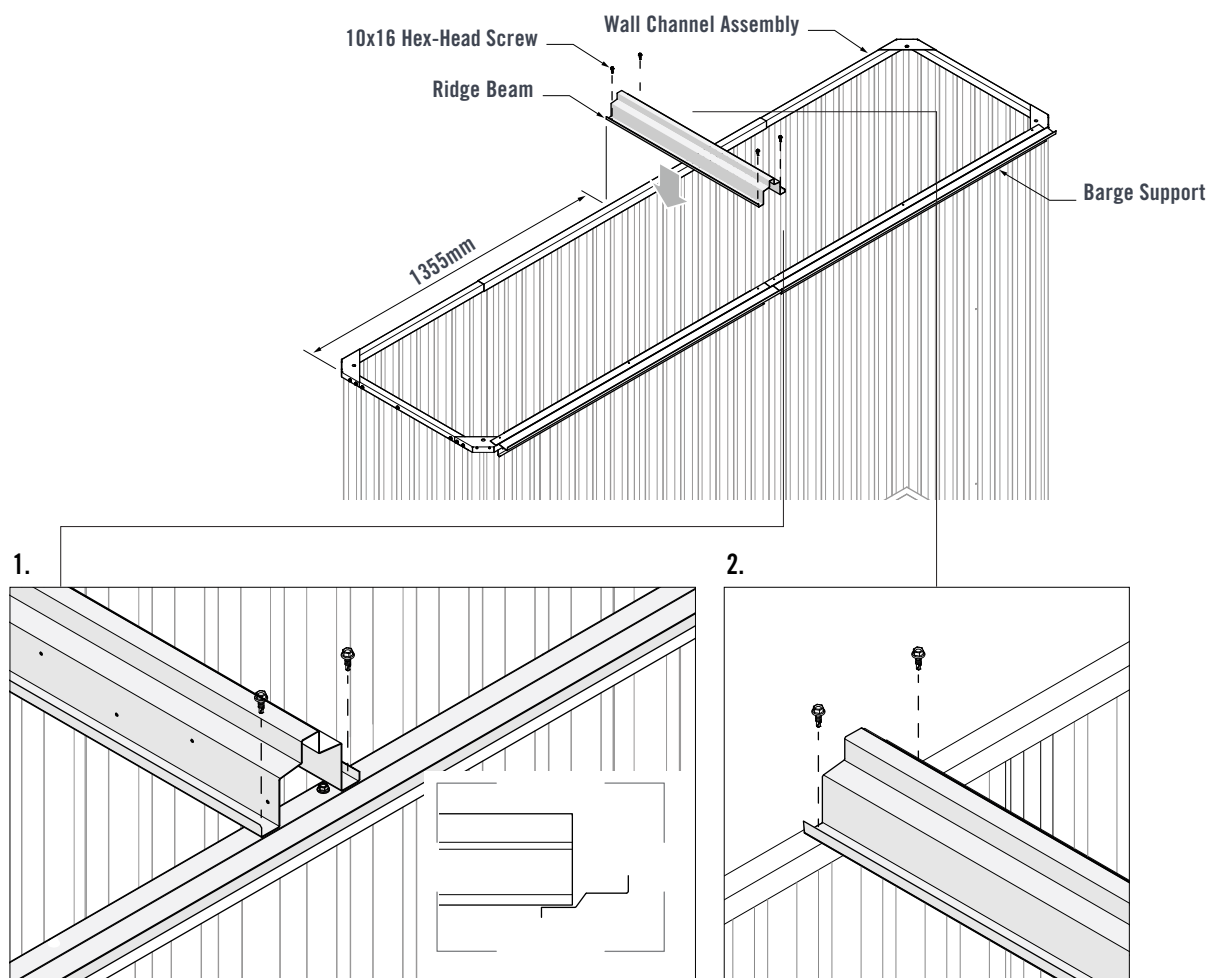

FIGURE 8.1

Use an adjustable spanner to turn up the pans at the ridge end of the Roof Sheets. This will prevent water flowing back under the sheet (Figure 7.2).

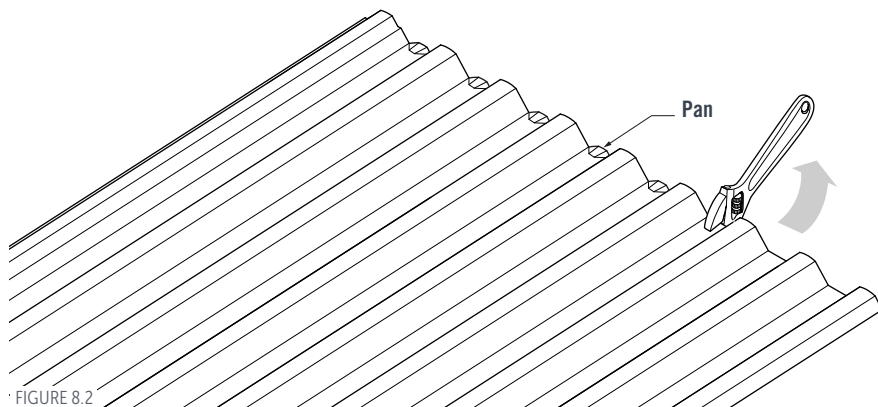

FIGURE 8.2

Lay a Roof Sheet onto the Ridge Beam and Wall channel (Short), ensuring the overlap end of the Roof Sheet is facing the front of the shed (Figure 8.2).

1. Ensure the middle of the Roof Sheet crest is in-line with the end of the Ridge Beam (Figure 8.2)
2. Ensure the Roof Sheet is hard against the step of the Ridge Beam. Fasten five 10x16 Hex-Head Screws with Neo Washers through the pans of the Roof Sheet and into the Ridge Beam (Figure 8.2).
3. Fasten five 10x16 Hex-Head Screws with Neo Washers through the pans of the Roof Sheet and into the Wall Channel (Figure 8.2).

Install the opposing side Roof Sheet in the same manner.

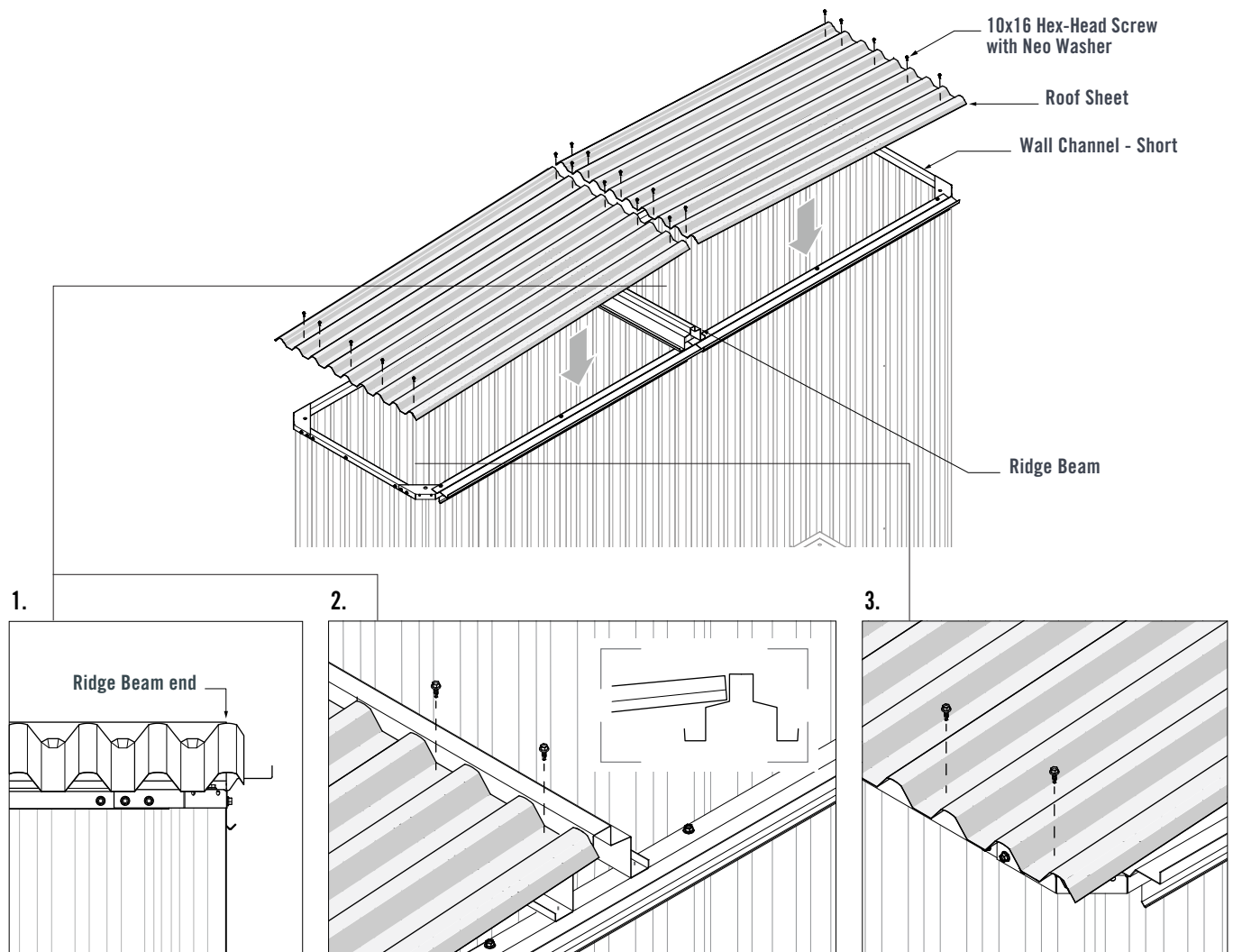

FIGURE 8.2

HANDI-MATE™ HML LOCKER SHED INSTALLATION GUIDE

Position the Ridge Cap over the Ridge Beam. The outside edge of the Ridge Cap should line up with the outer face of the Barge Support (Figure 8.3).

Fasten the Ridge Cap to the Ridge Beam using three 10x16 Hex-Head Screws with Neo Washers (Figure 8.3).

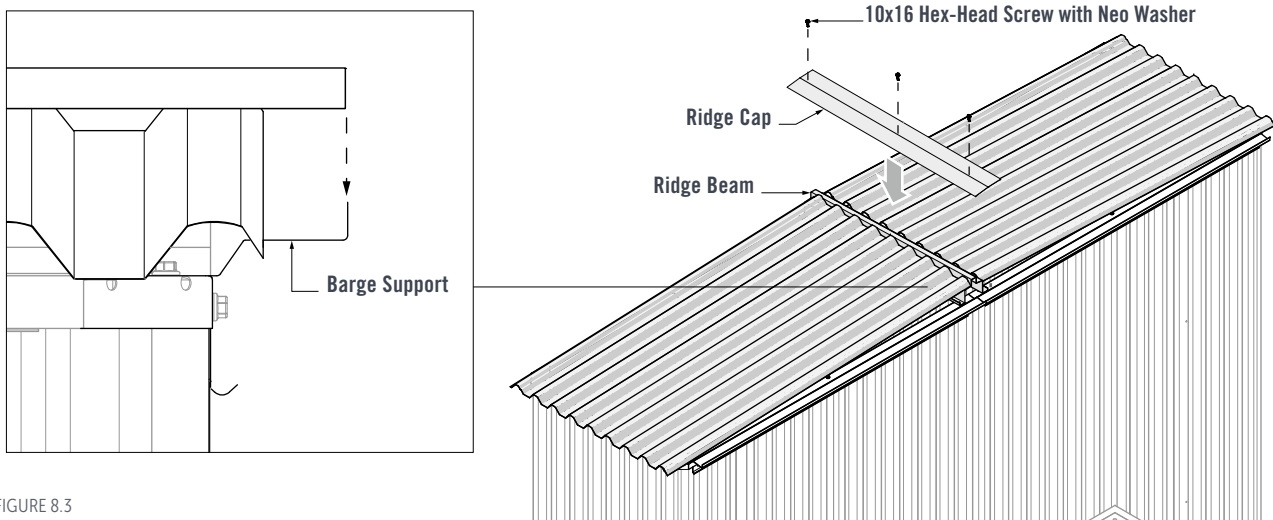

FIGURE 8.3

Fasten the Door Shroud to the back face of the Runner Rails with three 10x16 Hex-Head Screws (Figure 8.4).

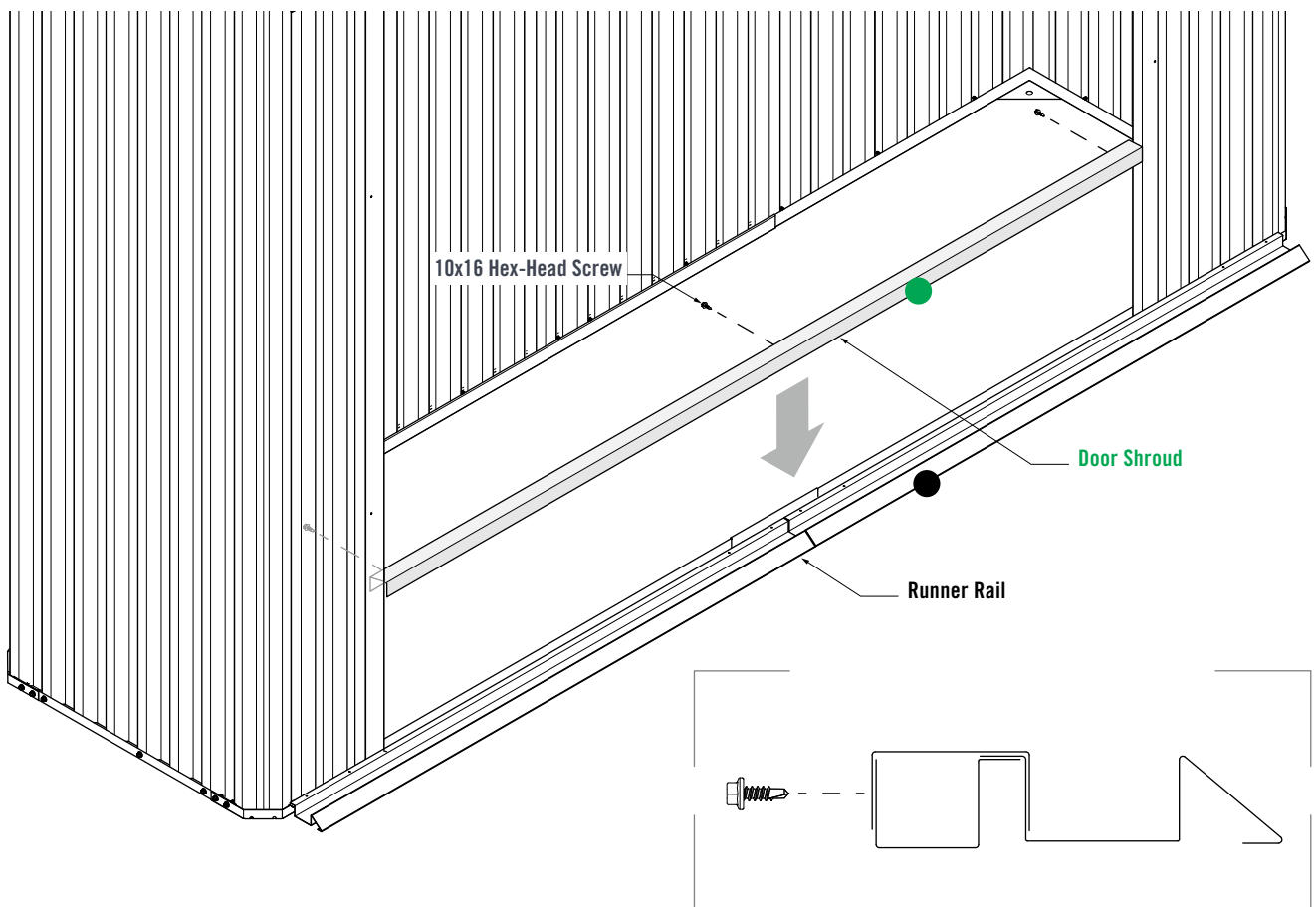

FIGURE 8.4

1. Slide the Left and Right Doors into the Sliding and Runner Rails. The Door Roller should fit into the Sliding Rail at the top. The bottom of the Door should fit into the Runner Rail at the bottom (Figure 8.5).

2. Fasten Door Stops through the pilot holes at both ends of the Sliding Rail with 10x22 Wafer-Head Screws. Fasten two more Door Stops to the other Sliding Rail, so that a Door Stop is installed at both ends of both Sliding Rails (Figure 8.5).

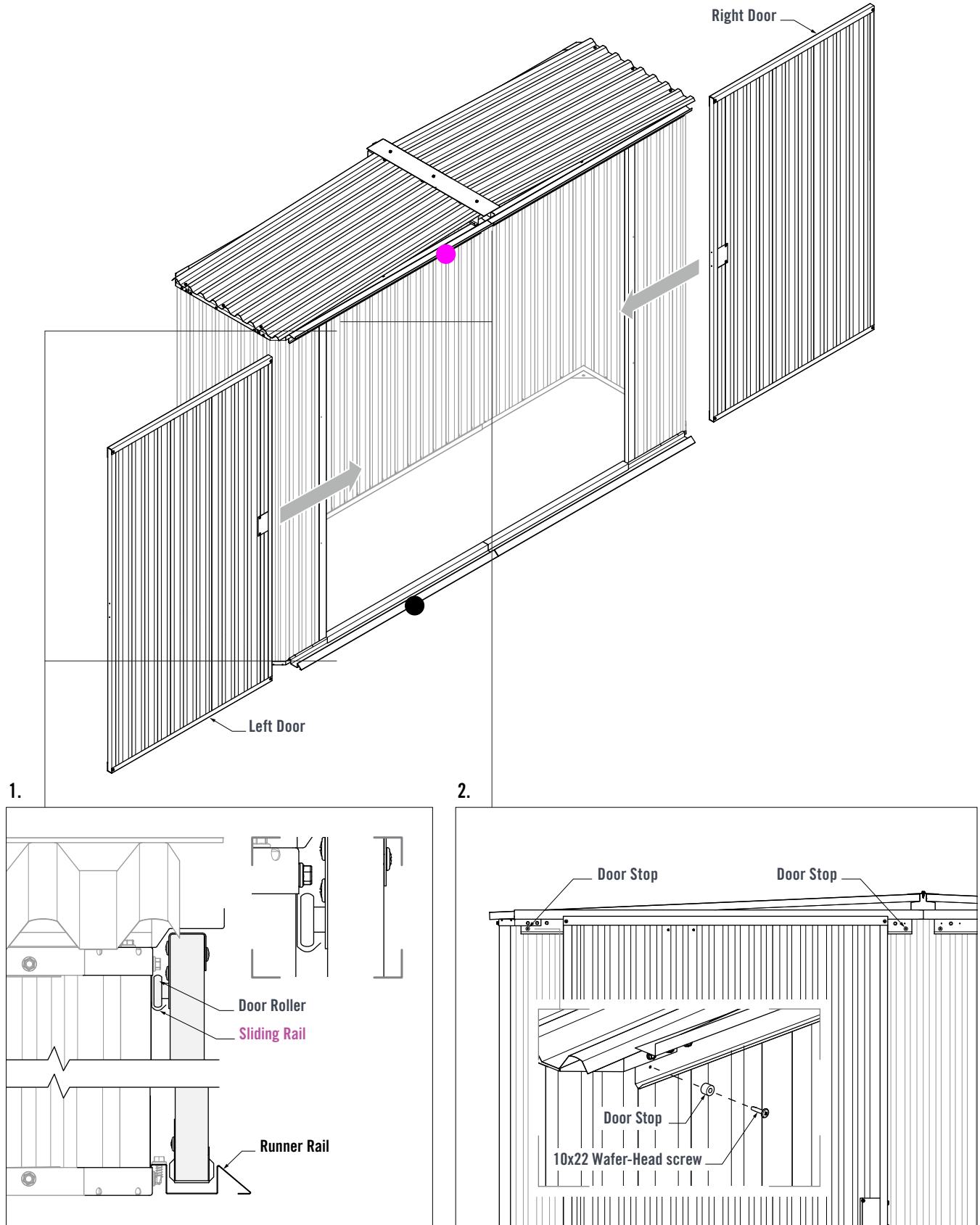

FIGURE 8.5

HANDI-MATE™ HML LOCKER SHED INSTALLATION GUIDE

On the inside of the shed, align the Padbolt along the Door edge. Fasten the Padbolt to the Door with two 10x16 Hex-Head Screws (Figure 8.6).

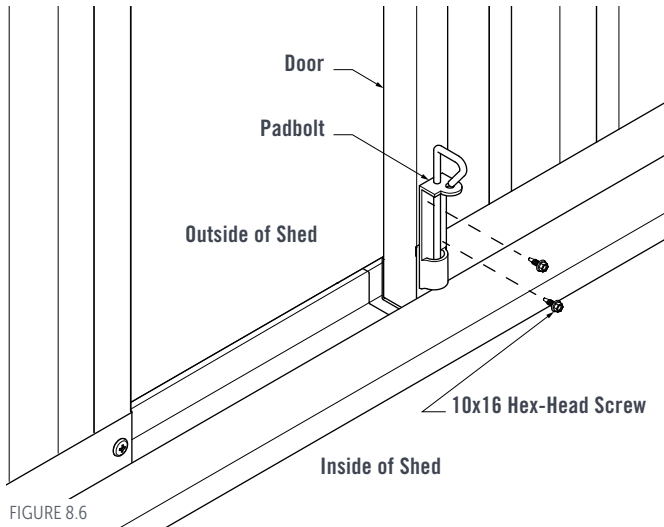

FIGURE 8.6

Align the Door edge with the meeting point of the Runner Rails (middle point of the shed). Mark the point where the Padbolt shaft touches the Door Shroud (Figure 8.7).

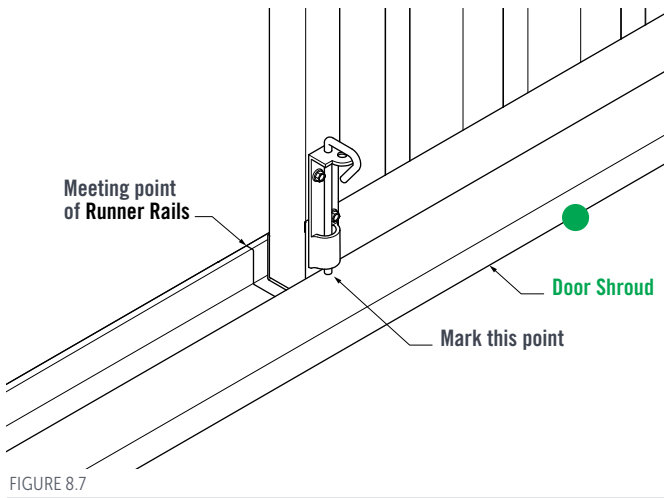

FIGURE 8.7

Drill a 3.5mm pilot hole through the Door Shroud and Runner Rail at the point marked in Figure 6.14. Then drill incrementally larger 6mm and 12mm holes (Figure 8.8).

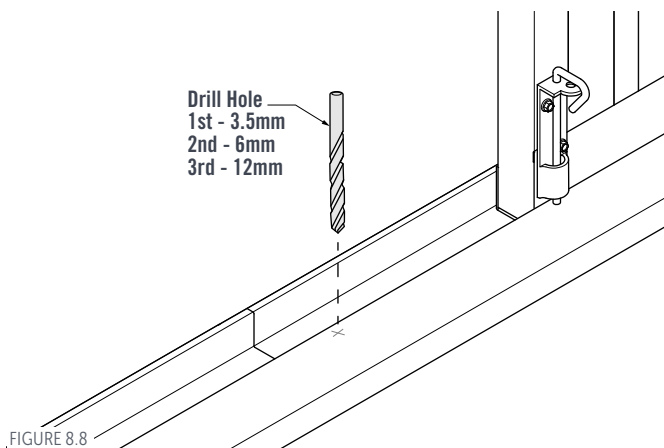

FIGURE 8.8

Position the Staple against the Handle Mount. Fix in place with four 10x16 Wafer-Head Screws (Figure 8.9).

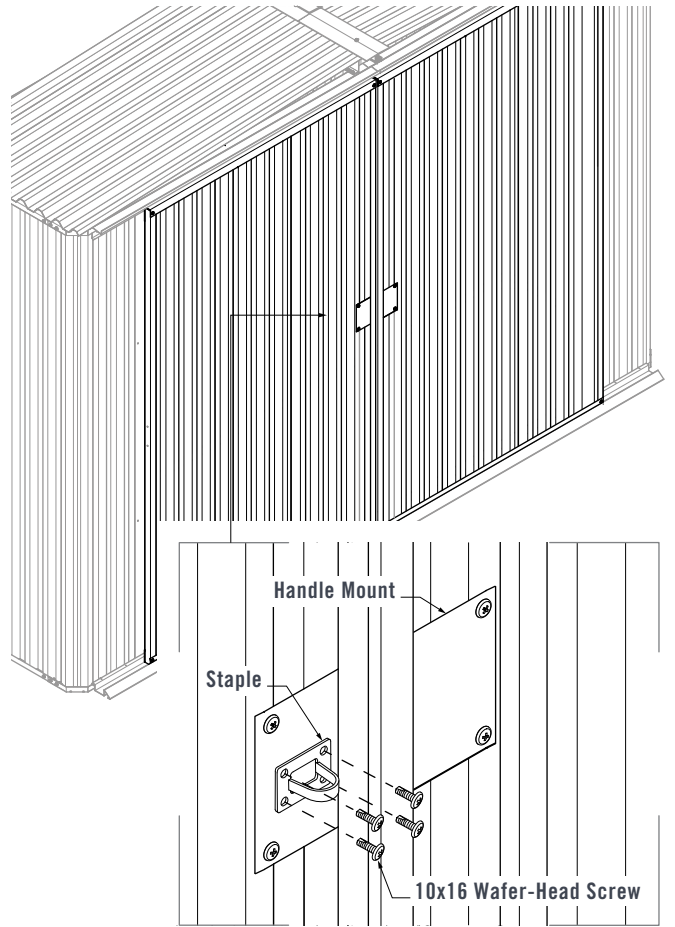

FIGURE 8.9

Locate the correct position of the Hasp by fitting the Hasp slot over the Staple. Position the Hasp against the Handle Mount. Fix the Hasp to the Handle Mount with three 10x16 Wafer-Head Screws (Figure 8.10).

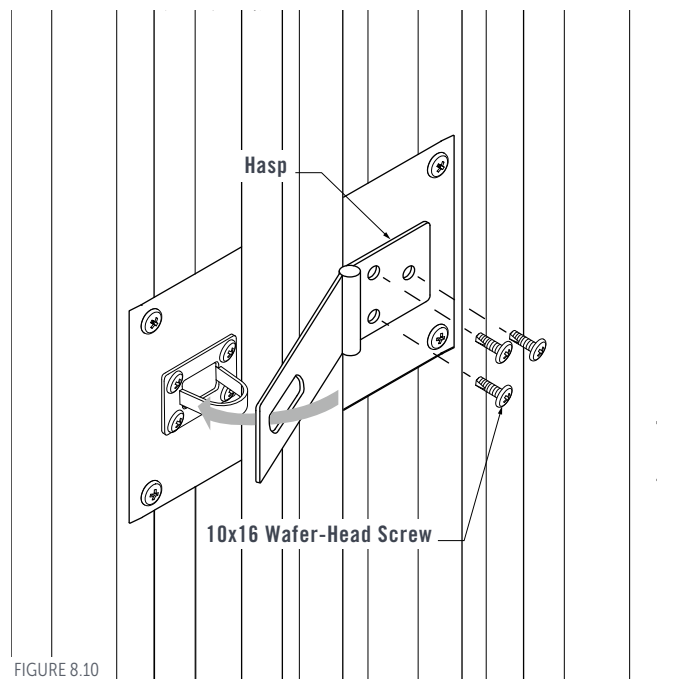

FIGURE 8.10

1. Place the L/H Barge Cap over the Roof Sheet at the front of the shed. The front face of the Barge Cap should fit up against the Barge Support. The ends of the Barge Cap should align with the end of the roof sheet (Figure 8.11).

Fasten two coloured 10x25 Hex-Head Screws with Neo Washers through the front face of the Barge Cap into the Barge Support. Fasten two coloured 10x25 Hex-Head Screws with Neo Washers through the top of the Barge Cap and into the crests of the Roof Sheets. Install the R/H Barge Cap in the same manner on the front right side of the shed (Figure 8.11).

2. Place the remaining L/H and R/H Barge Caps over the Roof sheets at the rear of the shed. Align the ends of each Barge Cap with the ends of the Roof Sheets (Figure 8.11).

Fasten two coloured 10x25 Hex-Head Screws with Neo Washers through the front face of each Barge Cap into the rear Wall Channel. Fasten two coloured 10x25 Hex-Head Screws with Neo Washers through the top of each Barge Cap and into the crests of the Roof Sheet (Figure 8.11).

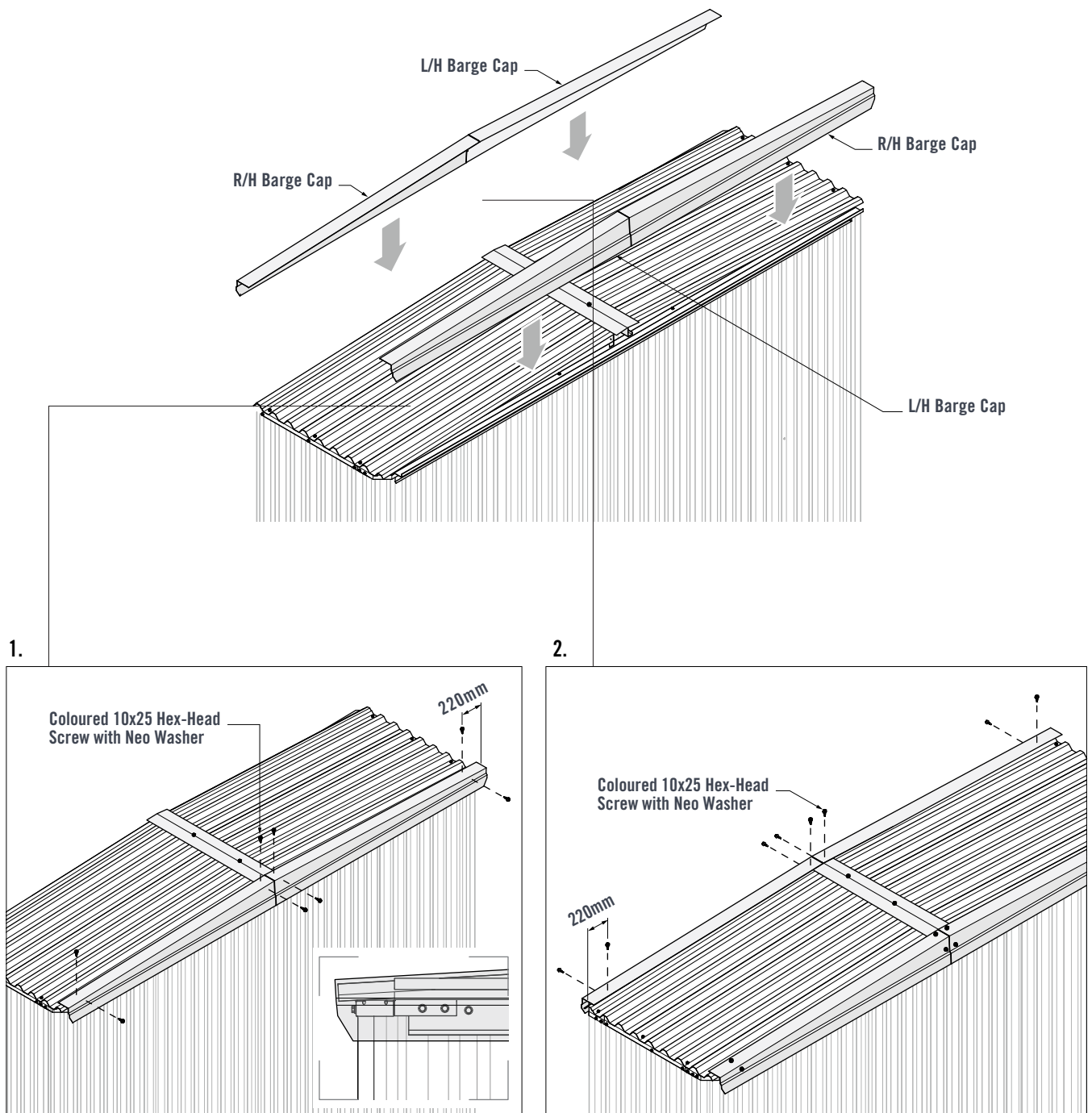

FIGURE 8.11

HANDI-MATE™ HML LOCKER SHED INSTALLATION GUIDE

A coloured Rivet should be installed at sheet laps in the rear wall, wall corners and door. Drill a 3.5mm hole through the centre of each sheet lap and install a coloured Rivet (Figure 8.12).

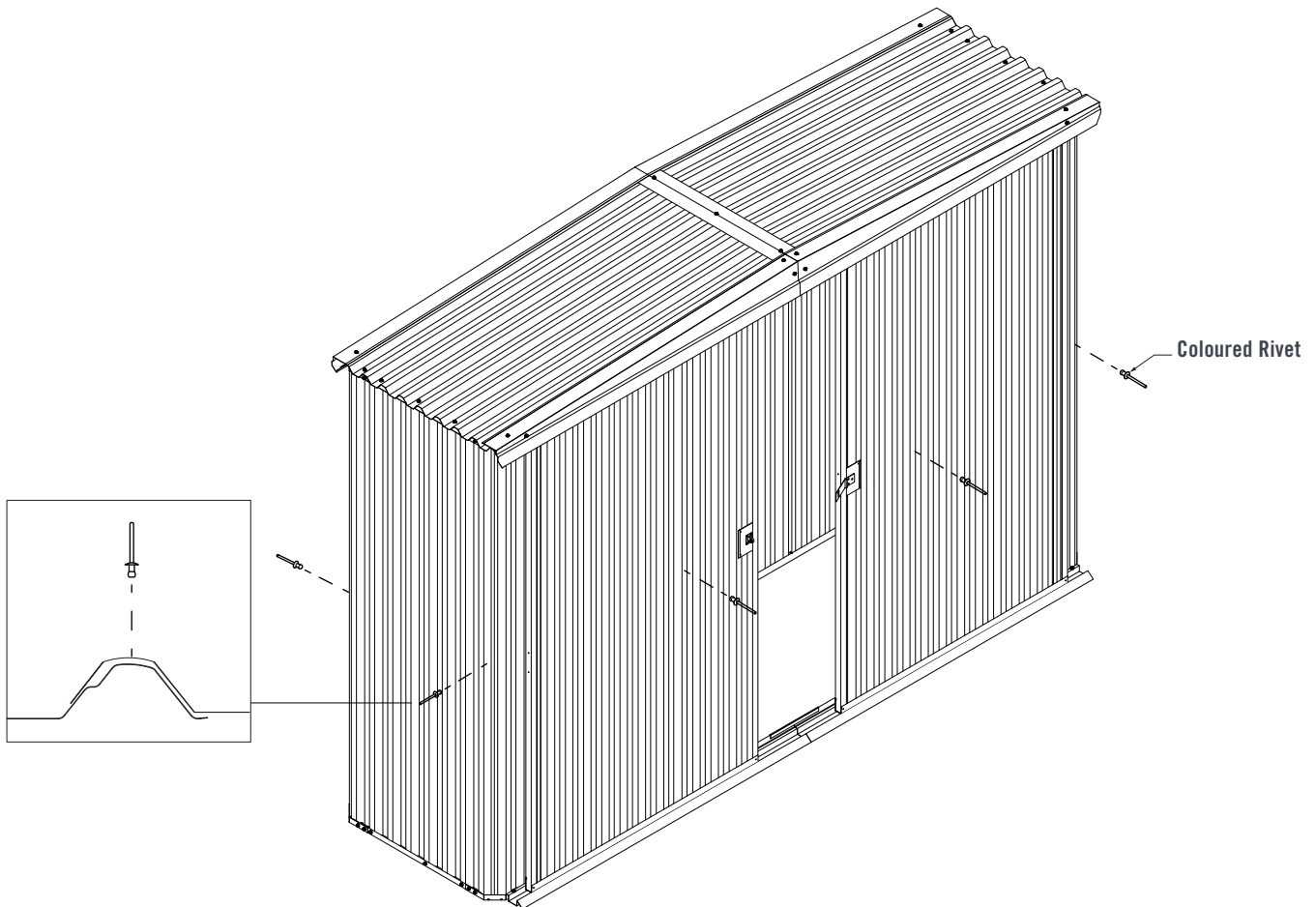

FIGURE 8.12

Water-Proofing the Floor (Optional)

Water may enter the Shed between the bottom Wall Channels and Floor. Water ingress can be mitigated by applying silicone to the gaps along the Floor. From the inside of the Shed, apply a bead of silicone along the entire perimeter of the Shed, including along the Corner Brackets and Wall Channel ends. Do not apply silicone to the outside of the Shed as this will not allow water to flow out and away from the Shed (Figure 8.13).

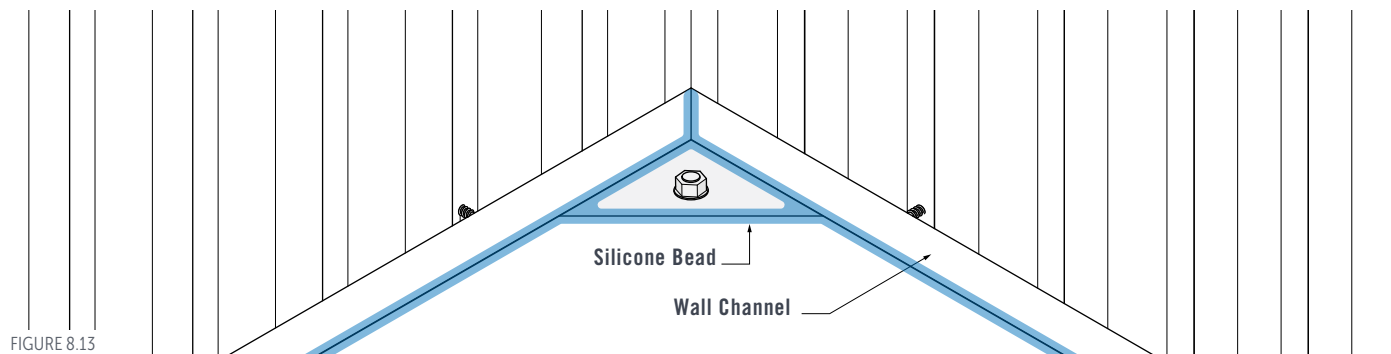

FIGURE 8.13

SHED MAINTENANCE

It is vital that all metal swarf and filings are removed from the shed as to prevent rust spots from forming. Your Stratco Handi-Mate™ Shed will maintain its good looks for even longer with a simple wash and wipe down. Cleaning should be performed as often as is required to remove any dirt, salt and pollutants.

Stratco Handi-Mate™ Sheds are produced from the highest quality materials and will provide many years of service. Refer to the 'Selection Use and Maintenance' brochure for more information on how to get the best out of your product.

WINDOW INSTALLATION

Stratco Shed Windows are an optional add-on, available in both Louvre and Sliding variations. Installation methods are identical for each window type. Windows can be installed only to the rear wall of the shed.

The Window must be installed during the assembly of the Rear Wall.

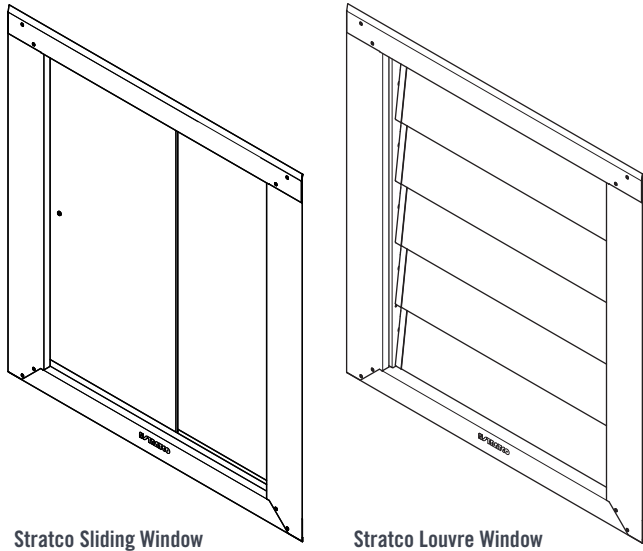

FIGURE 9.0

Lay a Wall Sheet on trestles or blocks. Mark and cut 750mm from the end of the Wall Sheet (Figure 9.1).

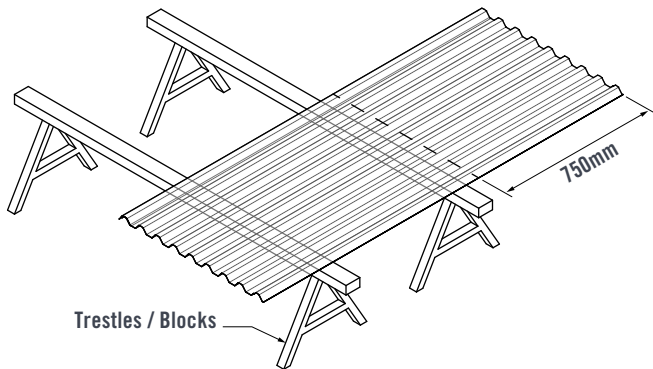

FIGURE 9.1

Assemble the Wall Assembly as per the "Rear Wall Assembly" section of the install guide using below sheet layout (Figure 9.2).

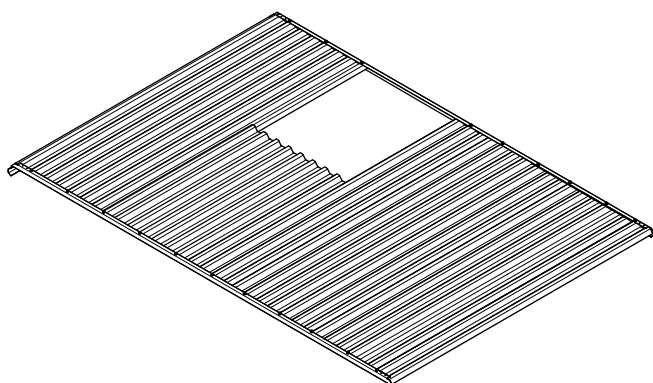

FIGURE 9.2

Fit the window within the opening. Ensure the top lip of the window is fitted between the Wall Channel and Wall Sheets. A minimum of four evenly spaced rivets must be used along each side of the window frame. All fasteners must be fixed through the crests of the Wall Sheets (Figure 9.3).

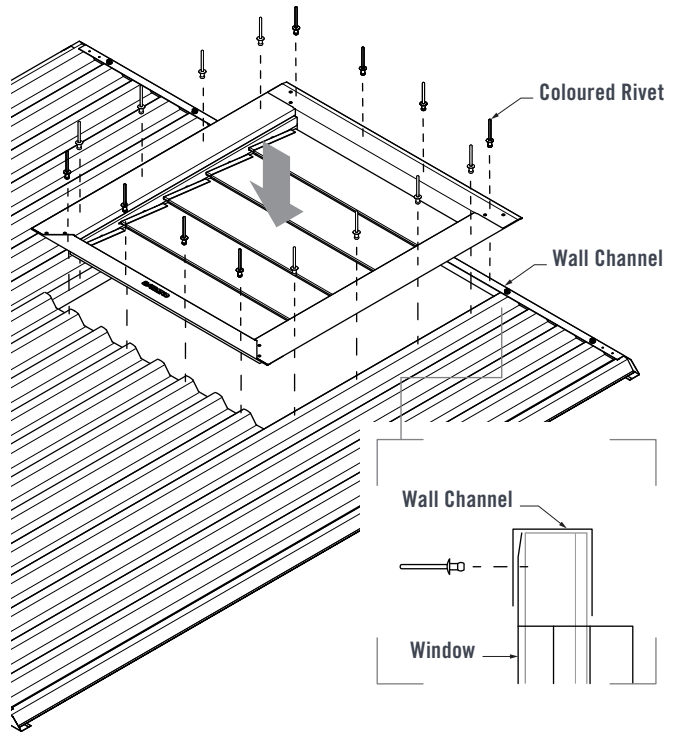

FIGURE 9.3

The Window Flashing must be fitted from the inside of the shed. Fit the short face of the Flashing between the window and the cut edge of the Wall Sheet. Secure the flashing to the Wall Sheet with four evenly spaced Rivets. Ensure all rivets are crest-fixed through to the sheets (Figure 9.4).

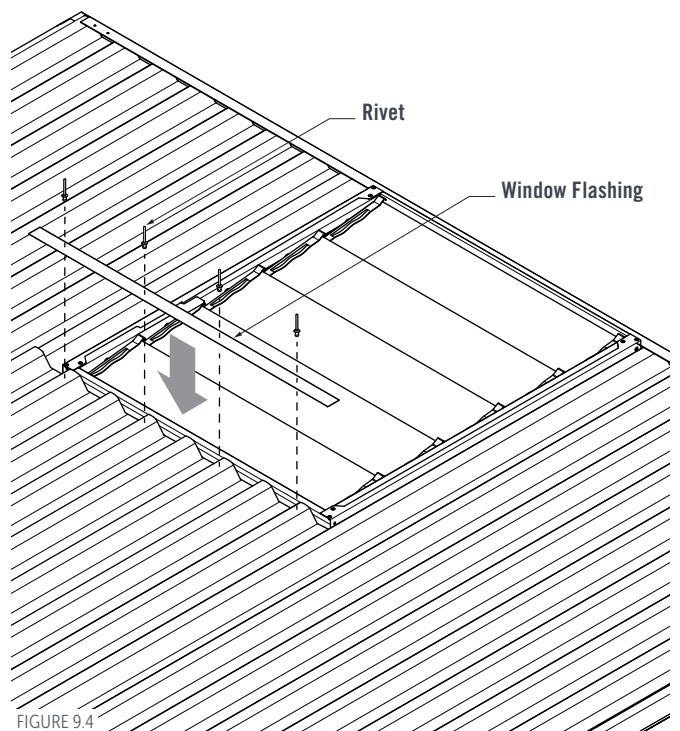

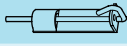



















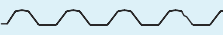

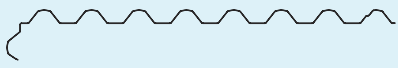













FIGURE 9.4

HANDI-MATE™ HML LOCKER SHED INSTALLATION GUIDE

COMPONENT INDEX

PROFILE	DESCRIPTION	PRODUCT CODE
	Hasp & Staple	PM-10873
	Pad Bolt	PM-10874
	Handle Mount	HMDM
	Corner Bracket	HMCB
	Door Jamb	HMDJ
	Door Shroud	HMDSHDRBO
	Top Door Channel	HMDCTO
	Bottom Door Channel	HMDCBO
	Vertical Door Channel	HMDCVE
	Wall Channel	HMWC
	Bottom Channel	HMBR
	Runner Rail	HMRRBO
	Sliding Rail	HMSR
	Sliding Rail Joiner	HSRJGA
	Ramp Channel Joiner	HRCJGA
	Barge Support	HMBS
	Barge Cap - Left Hand Side	HMBCHDRL
	Barge Cap - Right Hand Side	HMBCHDRR
	Ridge Cap	HMRC
	Ridge Beam	HMRB
	Roof Sheet	SSPHMRS
	Split Wall Sheet	SSPHMSW
	Split Door Sheet	SSPHMSD
	Split Corner Wall Sheet	SSPHMSWCNR
	Corner Wall Sheet	SSPHMWSCNR
	Wall Sheet	SSPHMWS



PROFILE	DESCRIPTION	PRODUCT CODE
	Hold Down Lug	HMHL
	Door Wheel	HMDW
	Door Stop	HMSS
	Door Nut	HMNN6
	Masonry Anchor	MAA847
	Rivet	RIV4-3
	16mm Wafer Head Screw	WTK1016
	22mm Wafer Head Screw	WTK1022
	16mm Self-Drilling Screw	TEKNNW1016
	16mm Self-Drilling Screw Neo Washer	TEK1016
	25mm Self-Drilling Screw Neo Washer	TEK1025
	Fasteners Kit	HMSKHSD



« SCAN THIS QR CODE TO FIND A STRATCO NEAR YOU

1300 155 155
stratco.com.au

All brands and logos/images accompanied by ® or ™ are trade marks of Stratco (Australia) Pty Limited. © Copyright July 2023

How To.

