



How To.

INSTALLATION GUIDE



BEFORE YOU START

It is important to check your Local Government Authority requirements before the installation of your new Stratco Outback® Flat Verandah. It is the builder's responsibility to ensure any existing structure that an Outback Flat is being attached to is adequately reinforced to accommodate the additional loads imposed by the verandah, patio or carport. Read these instructions thoroughly before starting your project and refer to them constantly during each stage of construction. Contact Stratco for advice if you do not have the necessary tools or information.

Before starting, lay out the main components in order of assembly on the ground and check them against the delivery note. The 'Components' section identifies each part of your Outback Flat Verandah and shows the relative location of the components.

Mark out the overall area of your verandah, patio or carport and ensure that it is free from obstructions. Beam to wall connections can cause difficulty if they coincide with door and window openings, so avoid these in your design. Ensure there is reasonable access for materials and working space and consider the disposal of run-off water. Check the column and beam positions on the ground; roughly check they are square by measuring the diagonals, then mark out the column locations. If columns are to be 'in ground', dig the holes to Stratco specifications.

If required, search the Stratco YouTube channel for our range of installation videos for additional guidance.

TOOLS REQUIRED

- Drill and Hex-Head Adaptor
- Rivet Gun
- Tape Measure
- Tin Snips
- Spirit Level
- Hacksaw
- Post Hole Digger
- Silicone Gun
- Spanners or Ratchet
- Adjustable Construction Props
- Concrete
- Ladder







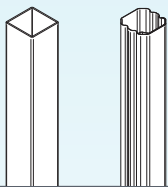
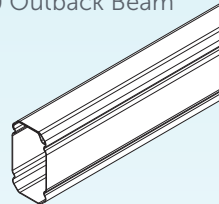
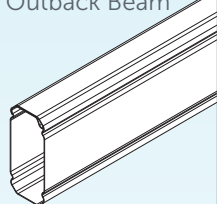
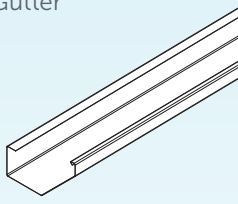
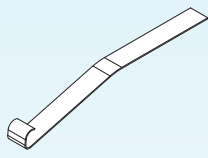
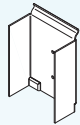
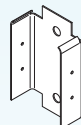
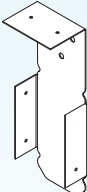
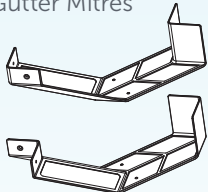
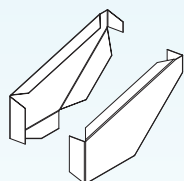

ADDITIONAL ITEMS

The components supplied do not include fixings to attach the unit to an existing structure or concrete/masonry anchors for the column installation. If required they must be purchased as additional items.

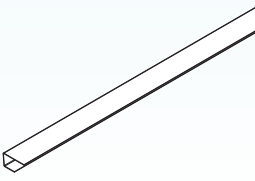
OUTBACK® FLAT ATTACHED

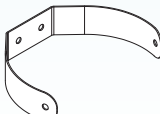
VERANDAH | PATIO | CARPORT - INSTALLATION GUIDE

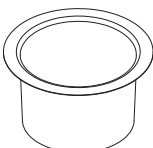
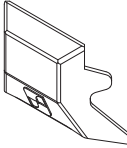
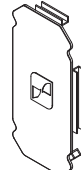
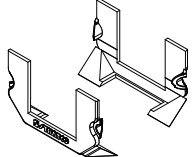
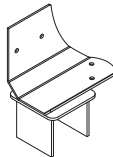
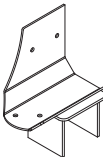
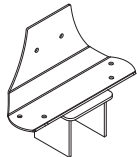
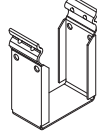
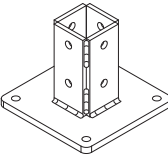
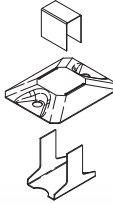
COMPONENTS

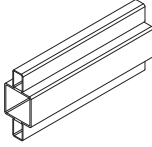
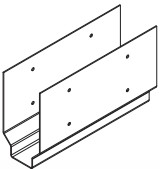
<p>Columns</p> 	<p>120 Outback Beam</p> 	<p>150 Outback Beam</p> 	<p>Gutter</p> 	<p>Universal Deck Strap</p> 
<p>Beam Bracket</p> 	<p>Wall Bracket</p> 	<p>Suspension Bracket</p> 	<p>External & Internal Gutter Mitres</p> 	<p>Gutter Stop Ends</p> 
<p>Roof Cladding</p> 	<p>Back Channel</p> 	<p>PVC Nitrile</p> 	<p>Downpipe Bracket</p> 	
<p>Downpipe</p> 	<p>Downpipe Outlet</p> 	<p>Post Cap</p> 	<p>Beam End Cap</p> 	<p>Beam Filler</p> 
<p>Notched Beam Filler</p> 	<p>Right Hand SHS Connector</p> 	<p>Left Hand SHS Connector</p> 	<p>Inline SHS Connector</p> 	<p>Post Beam Bracket</p> 
<p>SHS Footing Plate</p> 	<p>68 Bolted Footing Plate</p> 	<p>Outback Rooflite™</p> 	<p>Full Moment Beam Connector</p> 	<p>150 In-Line Beam Connector</p> 

COMPONENT DIAGRAM

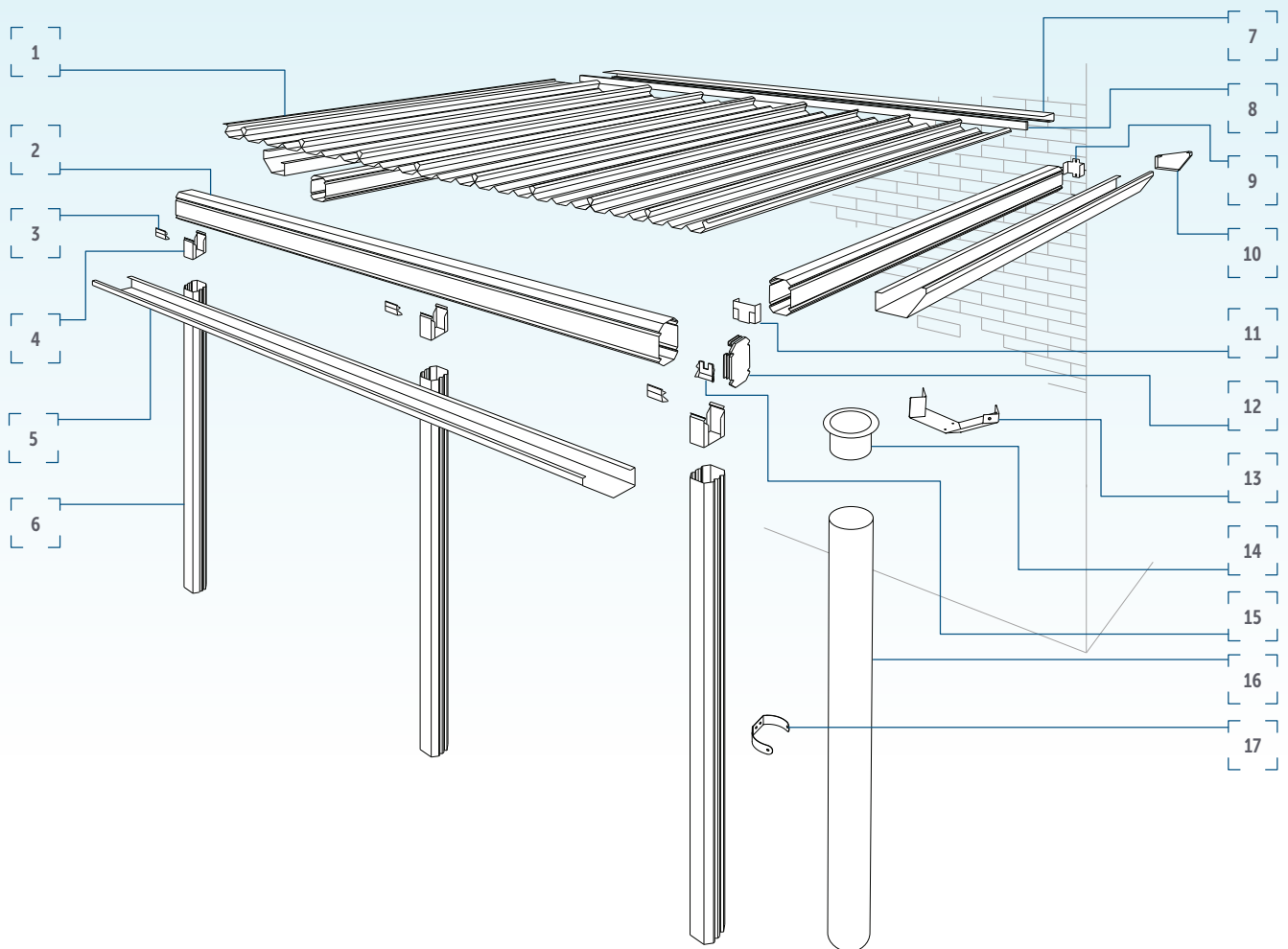

1. OUTBACK DECK
2. OUTBACK BEAM
3. POST CAP
4. POST BEAM BRACKET
5. OUTBACK EDGE GUTTER
6. 68 OUTBACK COLUMN
7. BACK CHANNEL
8. PVC NITRILE
9. WALL BRACKET

10. GUTTER END CAP
11. BEAM BRACKET
12. BEAM END CAP
13. GUTTER MITRE
14. DOWNPIPE OUTLET
15. BEAM FILLER
16. DOWNPIPE
17. DOWNPIPE BRACKET

BACK CHANNEL INSTALLATION

The short edge of the back channel is the underside. The back channel should extend 50mm past the end of the beam to allow for overflow into the gutter. If multiple lengths are required, butt the channels together and waterproof with silicone.

Determine what type of fascia you are attaching your unit to and what type of fixings and brackets you require (refer to "Attaching to a Structure" section). Pre-drill the back channel on the ground. Locate the first hole 100mm from the edge of the back face of each length of channel. Drill the other holes at 500mm centres for timber and brickwork or 250mm centres for steel fascia. Run two beads of silicone along the back of the back channel, with one near the top edge to ensure a water tight seal.

FASCIA ATTACHMENT

When fixing the back channel to fascia the roofing above each rafter must be removed to give adequate space to install the fascia strengthening brackets. M10 Bolts connect the fascia strengthening brackets to the rafter and fascia (the number of brackets required is determined by the builder, but the spacing should not exceed 1200mm). Silicone as shown in the diagrams. When fixing to timber fascia (Figure 1.0) attach the back channel using 12x25mm hex head timber fixing screws through the pre-drilled holes. When fixing to steel fascia (Figure 1.1) attach the back channel using 12x20mm hex head self drilling screws through the pre-drilled holes. The back channel is bolted through the fascia to the fascia brackets with one M10 bolt per bracket. Insert BIP foam into the back channel to act as a weather seal when the roof sheets are pressed into it.

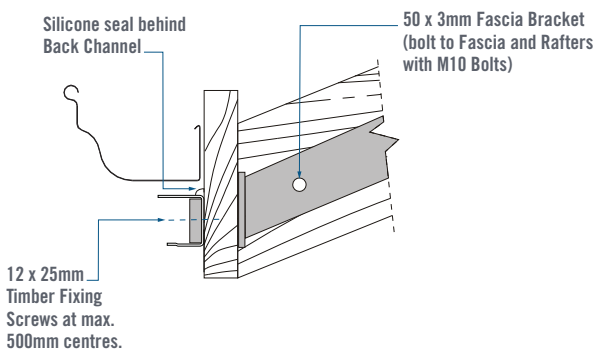

FIGURE 1.0

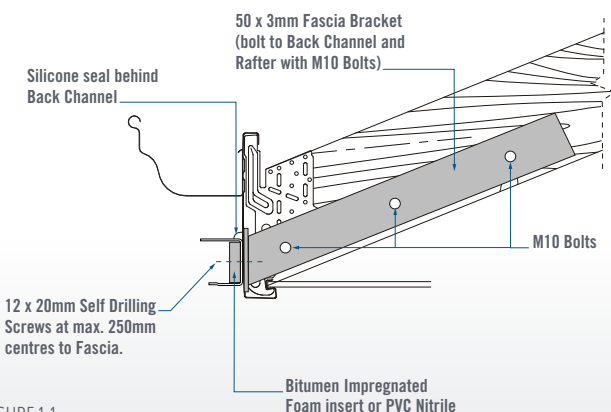

FIGURE 1.1

ATTACHING TO A BRICK WALL

When fixing the back channel to a brick wall, pre-drill the anchor holes using a masonry drill bit. Attach the back channel using M6x65mm masonry anchors through the pre-drilled holes (Figure 1.2). Insert the BIP foam into the back channel to act as a weather seal when the roof sheets are pressed into it.

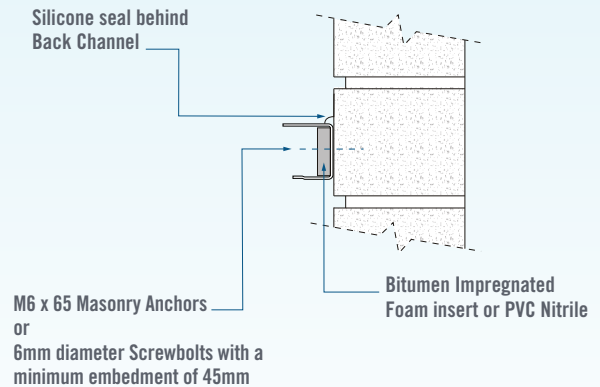

FIGURE 1.2

STEEL HOUSE FRAME ATTACHMENT

When fixing the back channel to the steel fascia on a steel framed house, the roofing above each rafter must be removed to allow enough room to install the rafter strengthening brackets.

Attach angle brackets to 75x25x1.6mm RHS reinforcement using 12x20 self drilling screws. Place the brackets above the first web or truss connection at least 900mm from the wall, and directly over the wall. Fasten with four 12x20 self drilling screws to the chord or rafter (Figure 1.3).

Attach the extended fascia strengthening bracket to the reinforcing RHS using 12x20 self drilling screws at 200mm centres. It is the builder's responsibility to determine the adequacy of the fascia and rafters and the frequency of the brackets for each individual situation (Figure 1.3).

For additional bracing, fix a tie down brace to the adjacent studs. Use two 12x20 self drilling screws to fix the tie down to the to chord, and on each stud use two 12x20 self drilling screws on either side of the truss or rafter. Fix the back channel to the fascia as previously mentioned.

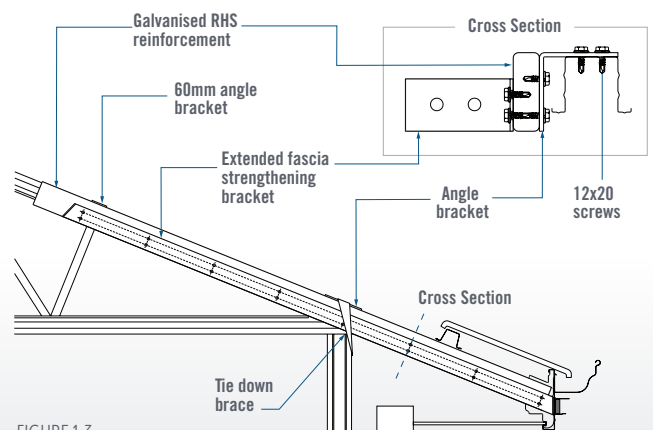

FIGURE 1.3

ATTACHING TO A STRUCTURE

WALL ATTACHMENT

For units attached to a wall, position the wall brackets where the beams meet the wall. The folded section on the tabs of the bracket is located at the top. The highest point of the wall bracket will be 15mm below the top beam. Mark the holes and drill using an 8mm masonry bit. Fasten the bracket to the wall with two M8 masonry anchors to a minimum 65mm embedment. The beam is slid into position and fastened with four 12x20 self drilling screws (Figure 2.0).

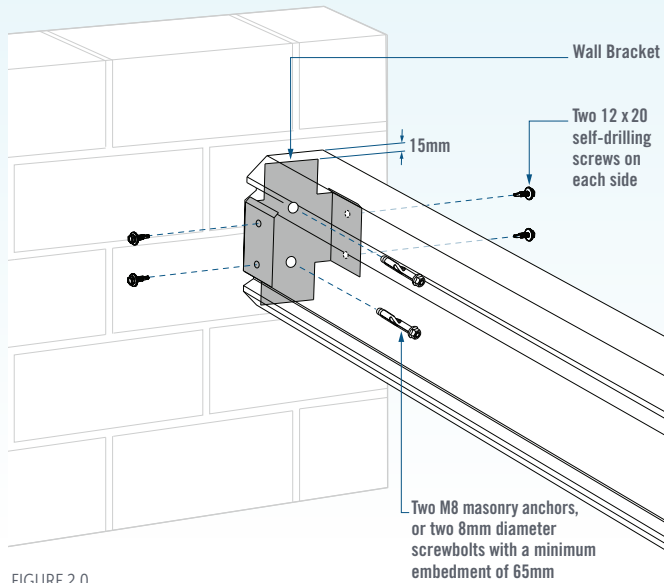

FIGURE 2.0

SUSPENSION BRACKET ATTACHMENT

A suspension bracket is used when a beam is suspended from the fascia. The top tab of the bracket must be located under and over the back channel. Use silicone to seal behind the suspension bracket and fascia. For steel fascia a minimum of three 12x20 hex head screws are fixed through the back channel, suspension bracket and fascia (Figure 2.1). For timber, three 12x25 type 17 screws are used to fix through the back channel, suspension bracket and timber. The rafter is slid into position and fastened using four 12x20 self drilling screws (Figure 2.1).

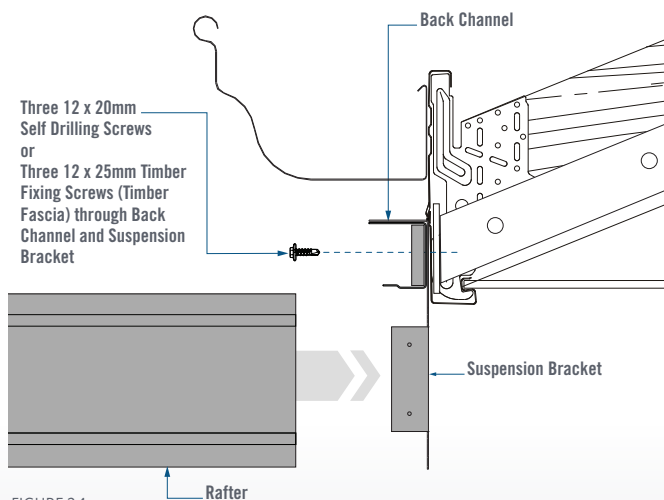

FIGURE 2.1

FLYOVER ATTACHMENT

Refer to the Outback Flyover Installation Guide document for specific Flyover attachment details.

FRAMEWORK ERECTION

END FASCIA BEAM

When installing all beams, ensure the double thickness of the beam is on top. Install the end fascia beam furthest from the downpipe first. Lift the back channel end of the beam up into the wall or suspension bracket while supporting the other end on an adjustable construction prop. Adjust the construction prop to allow for the required deck fall minimum of one degree (or one and a half degrees for deck spans over 4000mm). Fasten the end fascia beam to the bracket using two 12x20 hex head screws either side in the holes provided (Figure 3.0).

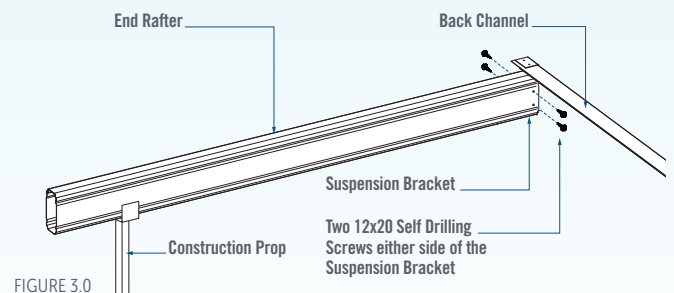

FIGURE 3.0

BRACKET AND FILLER CONNECTIONS

Measure the front fascia beam. Mark where the end fascia beams, intermediate beams (if required) and columns meet. Clip the post brackets onto the bottom of the front fascia beam where the columns will sit. Fasten through the holes in the post bracket with two 10x25 countersunk screws each side into the flute of the beam (Figure 3.1).

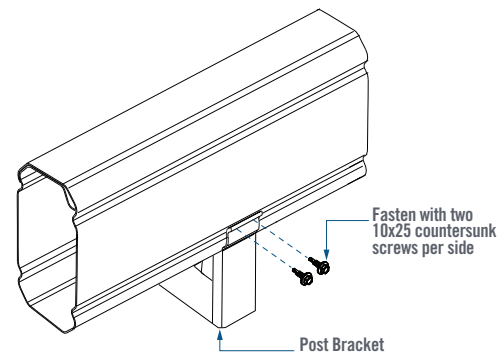

FIGURE 3.1

Place the beam brackets on the inside face of the front fascia beam, aligning their curved flange with the top groove of the beam so that they clamp the beam fillers (notched beam filler if over a post bracket) in place, fasten using two 12x20 self drilling screws (Figure 3.2).

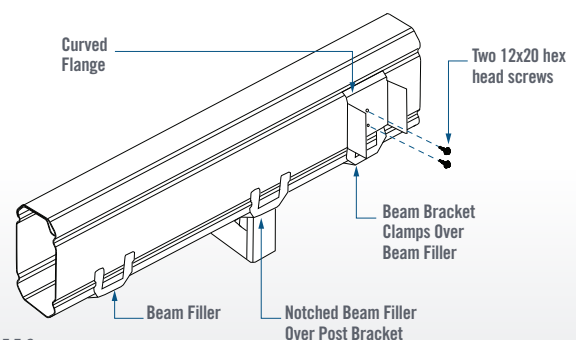

FIGURE 3.2

FASCIA BEAM TO RAFTER CONNECTION

Lift the front fascia beam and slide the rafter bracket onto the end of the rafter beam so that the end of the rafter is butted up against the back of the bracket. Support the front fascia beam on construction props allowing for a 1 in 500 fall. Fasten the rafter beams either side with two 12x20 self drilling screws (Figure 3.3).

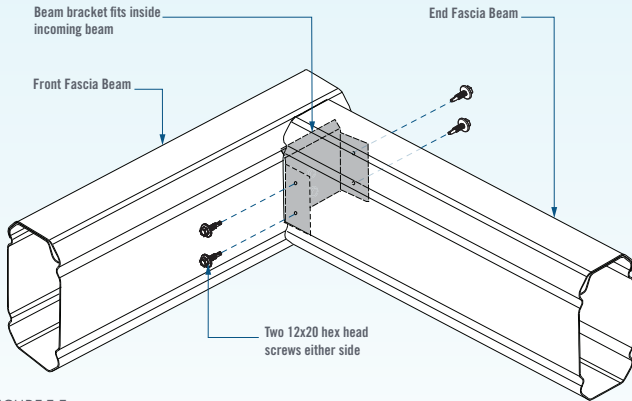

FIGURE 3.3

IN-LINE BEAM CONNECTION

To butt join beams together an in-line beam connector is used. The connector is placed so the join is in-line with the centre of a column. On the ground, slide the connector into the end of the beam. Fix using four 12x20 hex head screws either side. Push the exposed half of the in-line connector into the other beam until both beams meet flush and fasten as previously described (Figure 3.4).

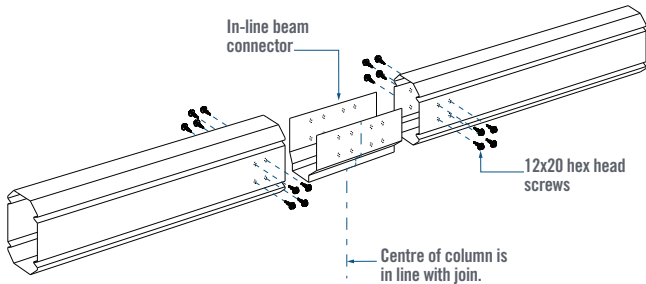

FIGURE 3.4

FULL MOMENT BEAM CONNECTION

If the beams must be joined at a location other than over a post, a full moment beam connection is required (Figure 3.5). Slide the connector halfway inside the beam while it is still on the ground. Fix the connector in place using six 12x20 self drilling screws; two either side of the beam and two on top of the beam. Push the exposed half of the in-line connector into the other beam and fasten using six 12x20 self drilling screws.

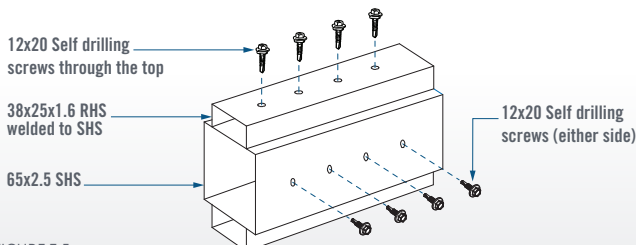

FIGURE 3.5

INTERMEDIATE BEAMS AND PURLINS

Intermediate beams and purlins may be fitted at this stage or following installation of the columns. Work progressively from the first end of the unit. Locate the rafter brackets and suspension brackets in the correct positions and fasten as previously described. Lift the first intermediate rafter into place and support on adjustable construction props (Figure 3.6). Secure all connections using two 12x20 hex head screws either side of each bracket. Continue this process along the Outback unit until the final end rafter beam is fixed in place.

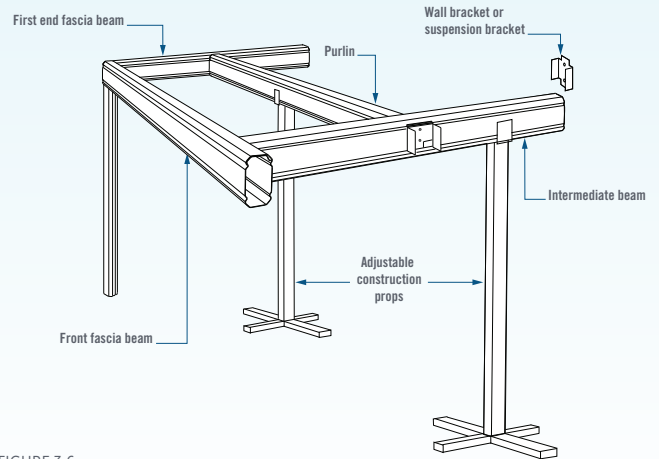

FIGURE 3.6

FRAMEWORK CHECK

Check that the basic framework is square by ensuring the diagonal measurements are the same. Recheck the falls are correct for the roof and gutter (Figure 3.7).

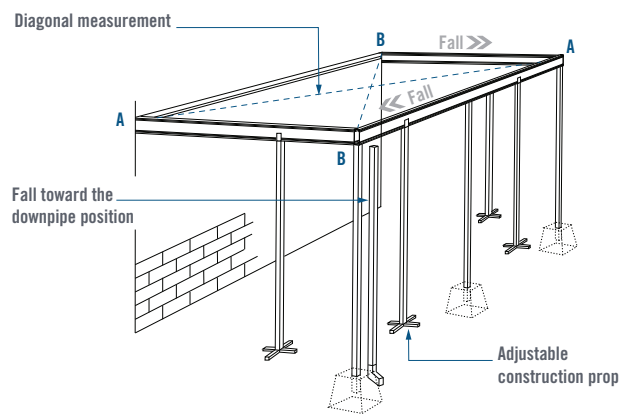

FIGURE 3.7

COLUMNS AND FOOTINGS INTO CONCRETE

If fixing the columns into the ground, dig the holes to the specified size. Place a half brick in the bottom of the hole (Figure 4.0).

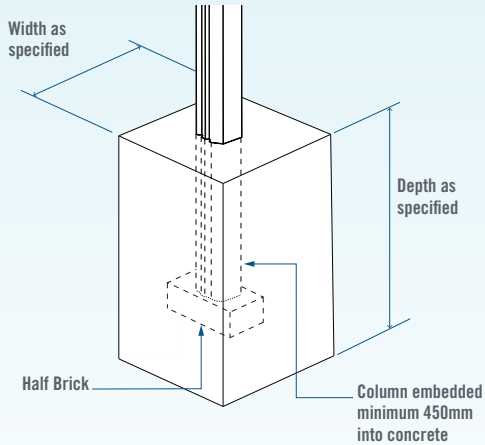

FIGURE 4.0

Measure from the underside of the beam to the top of the half brick and cut posts to this length at each post location.

Use construction props or bracing to hold columns in position, but do not concrete in place at this stage.

FOOTING ONTO CONCRETE

Footing brackets are available if the posts are to be fixed to an existing concrete slab. Establish the column lengths by measuring the distance from the underside of the fascia beam to the concrete slab (less the thickness of the footing plate or 20mm for Outback footing plate).

68 OUTBACK FOOTING PLATE

For non-reinforced 68 Outback posts, cut the columns to length, and assemble the footing bracket by sliding the legs of the footing upstand through the slots in the footing plate (Figure 5.0). The upstand bracing must be located between the legs of the upstand.

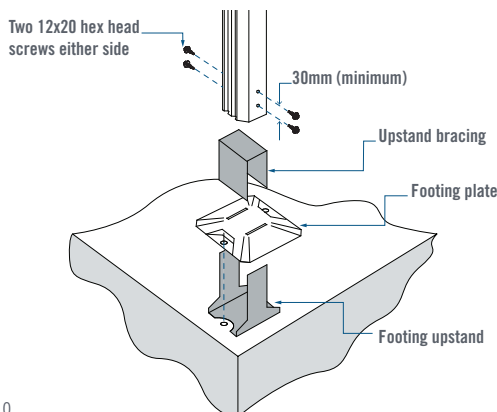

FIGURE 5.0

Slide the assembled footing bracket and bracing into the bottom of the column, and fasten with two 12x20 hex head screws either side ensuring the top screws are located at least 15mm from the top of the upstand with screws being a minimum 30mm apart (Figure 5.0).

Slide the top of the column over the post bracket and align

the column and footing bracket. (Note: It may be necessary to lift the fascia beam slightly to slide the column over the post bracket). The unfluted faces of the column should be aligned with each face of the post to beam bracket. Fasten using two 12x20 hex head screws either side (Figure 5.0).

Use construction props or bracing to hold columns in position but do not bolt to the concrete slab at this stage.

SHS COLUMN FOOTING PLATE

Slide the SHS column footing bracket into the bottom of the column, and fasten with two M10 bolts through the post (Figure 5.1).

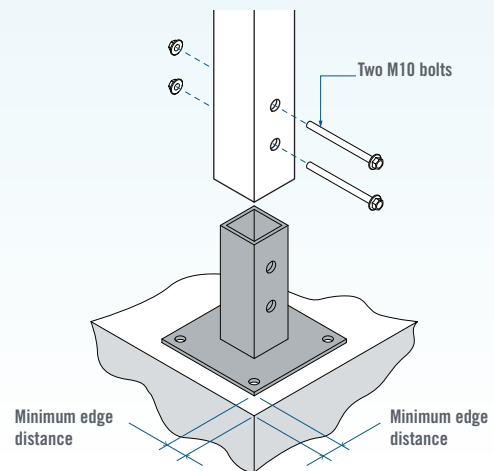

FIGURE 5.1

Screw the corner connector or inline connector to the top of the SHS post with two 12x20 hex head self drilling screws on either side of the column (Figure 4.2). Stand the post in position and screw the connector to the outside face of the beam with 12x20 self drilling hex head screws (Figure 5.1).

Use construction props or bracing to hold columns in position, but do not bolt to the concrete slab at this stage.

SHS INTERNAL UPSTAND

Position SHS over the internal upstand and ensure the upstand mounting holes are at least 75mm from the edge of the concrete (Figure 5.2). Do not fix the SHS column to the upstand at this stage.

Use construction props or bracing to hold columns in position but do not bolt to the concrete slab at this stage.

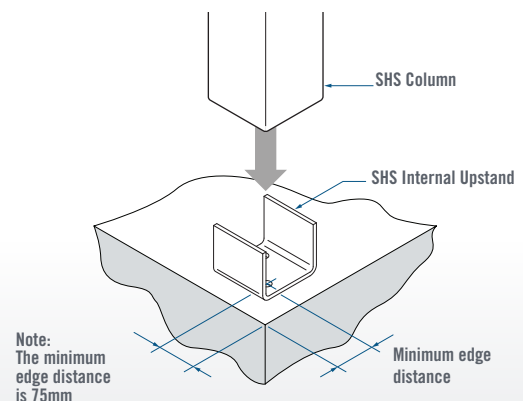

FIGURE 5.2

ATTACH COLUMN TO POST BRACKET

Slide the top of the column over the post bracket and align the column and footing bracket if applicable. It may be necessary to lift the fascia beam to slide the column over the post bracket. The un-fluted faces of the column should be aligned with each face of the post to beam bracket. Fasten with two 12x20 hex head screws either side (Figure 5.2). Post caps are used to cover the screw heads, press firmly into position, silicone can be used to provide a better fixing.

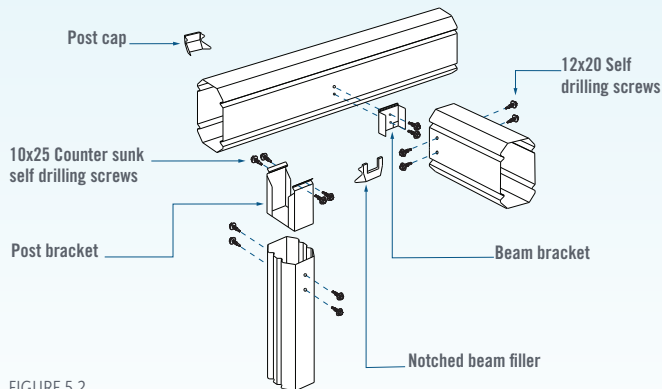

FIGURE 5.2

SQUARE HOLLOW SECTION (SHS) COLUMNS

If 65x65mm or 75x75mm square hollow sections (SHS) have been supplied, an alternative post to beam connection method is used.

Measure from the underside of the beam to the top of the half brick and cut posts to this length. Screw the corner connector or inline connector to the top of the SHS post with two 12x20 hex head self drilling screws on either side of the column (Figure 5.3).

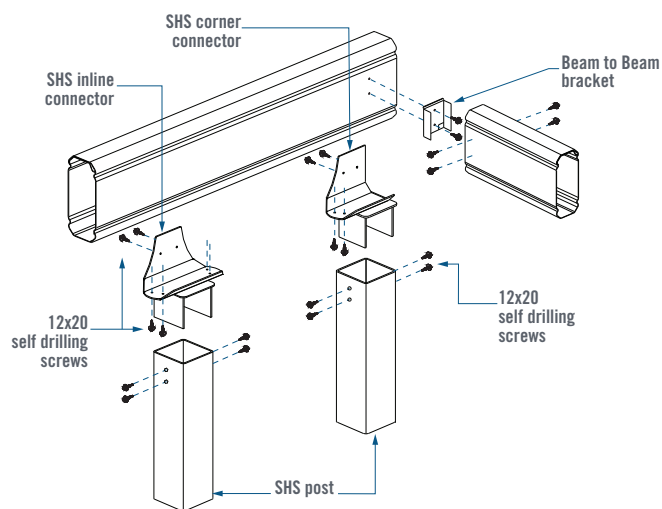

FIGURE 5.3

Stand the post in position. Screw the connector to the outside face of the Outback beam with 12x20 self drilling hex head screws (Figure 5.3).

Use construction props or bracing to hold columns in position but do not fix in place at this stage.

DECKING

TURNING THE DECKING ENDS

While still at ground level the ends of the decking need to be turned up or down approximately 30 degrees using a turn up/down tool to aid in weather proofing. Turn the ends of the decking up at the back channel end and down at the gutter end (Figure 6.0).

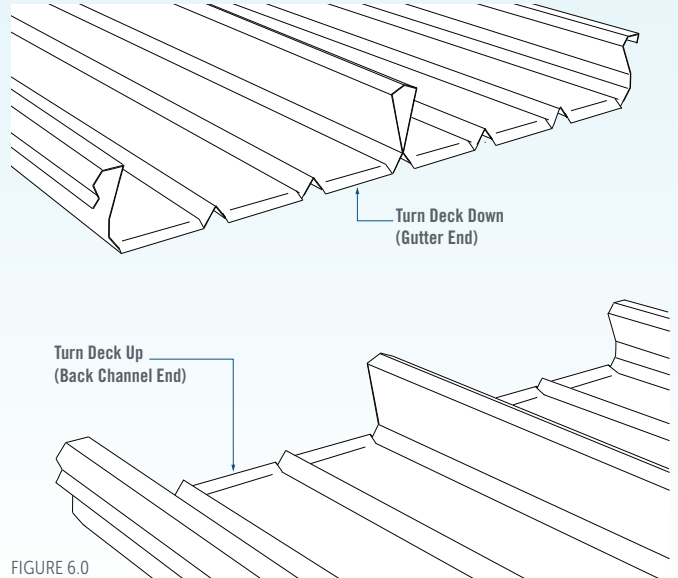

FIGURE 6.0

LAYING AND INSTALLING THE DECKING

Decking should have a 50mm overhang into the gutter and is laid with the overlapping rib facing away from the prevailing wind (Figure 6.1). Ensure all of the sheets have locking ribs on the same side. Mark the back channel and front fascia beam every 1000mm to check the decking is laid square.

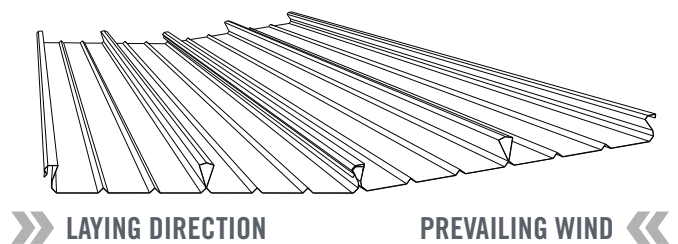

FIGURE 6.1

Lift the first sheet into place and push it firmly into the BIP foam in the back channel to weather proof it. Check the sheet is square against the back channel and side fascia beam. At the back channel end, rivet the decking from underneath through the raised edge on the bottom of the back channel with two 3.2mm rivets per pan (Figure 6.2). Seal the rivets with silicone. At each supporting beam, fix the sheet with two 12x20 hex head self-drilling screws per pan (Figure 6.2) (In cyclonic conditions use three 12x20 hex head self drilling screws per pan on supporting beams and three rivets per pan at the back channel). Remove any swarf.

Lay the next sheet of decking over the previous sheet's side lap (Figure 6.1). At the back channel end press down on the lap until the sheets clip together, continue working along the length of the sheet using a timber block (to avoid damaging the sheet) and rubber mallet. Finish by sliding the roof sheet firmly into the BIP foam in the back channel. For larger spans you may need to temporarily support the underside of the roof sheeting while clipping the laps together. Continue this process until all the roof decking is installed.

DECKING PARALLEL TO BACK CHANNEL

If the decking runs parallel to the back channel, slide the first roof sheet sideways into the BIP foam in the back channel for a weather proof seal. The sheeting is secured to the back channel with rivets at 200mm centres (150mm centres for cyclonic conditions), and it is secured to the beams running parallel with the decking using hex head screws at 500mm centres. The roof sheets are fixed as standard to the supporting beams (Figure 6.2).

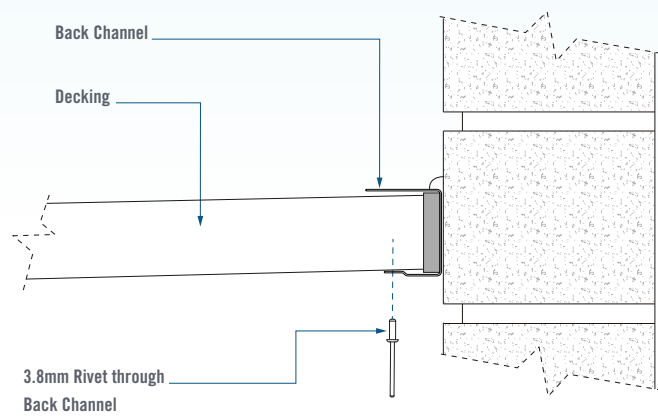

FIGURE 6.2

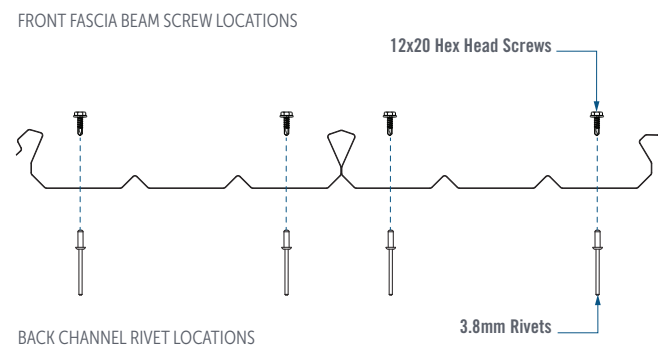

FIGURE 6.3

OUTBACK ROOFLITE™ INSTALLATION

An Outback Rooflite can be used to add natural light. The polycarbonate Rooflite overlaps the deck by snapping or sliding over the already installed sheets that have been spaced 250mm apart. Note: the profile of the Rooflite is different on each side, and therefore must align with the correct connection on the deck (Figure 7.0).

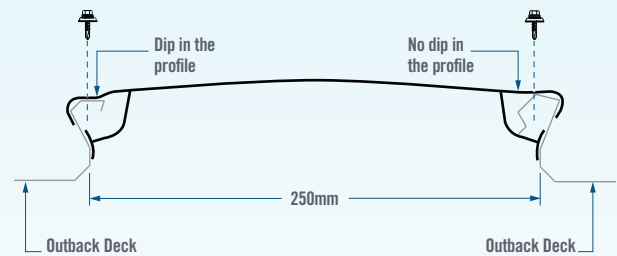

FIGURE 7.0

Ensure the lower tab of the Rooflite touches the Outback deck at the points shown (Figure 7.0) and all sheeting is pushed firmly into the back channel. 9mm holes must be pre-drilled through the Rooflite at all of the fastener locations prior to fixing to allow for thermal expansion. The Rooflite is fastened using 12x20mm hex head self-drilling screws with domed washers at maximum 2000mm centres. Fix through the groove located along the top of the Rooflite connectors (Figure 7.1).

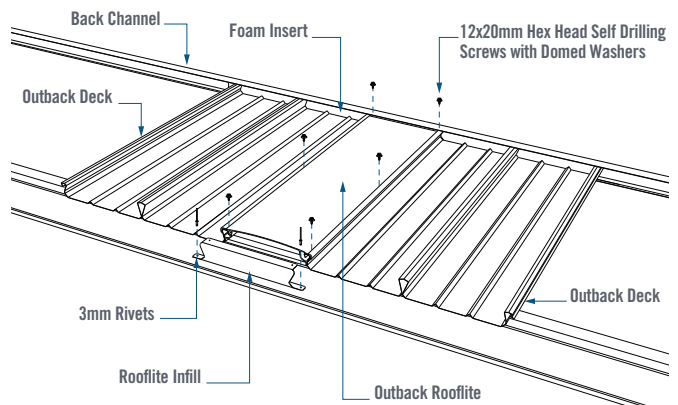

FIGURE 7.1

To finish the exposed end of the Rooflite an infill is required. Fasten the infill over the Rooflite with 12x20mm screws and domed washers on both sides through the pre-drilled holes. Connect the infill to the underside of the decking with 3mm rivets, seal the rivets with silicone. Finally, a foam insert is placed into the back channel end of the Rooflite.

CAPPING

BEAM CAPS

To prevent moisture from entering the beams and for aesthetics, any beams with exposed ends require end caps to be fitted. Align the end cap and push into the exposed beam end (Figure 8.0).

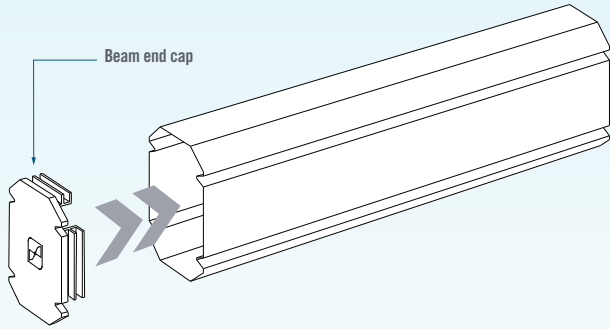

FIGURE 8.0

POST CAPS

If Outback columns are used, the post caps can be fitted over the post-beam connection. Apply a small amount of silicone to back of post cap, align the two lugs with the two exposed holes of the post bracket and push firmly (Figure 8.1).

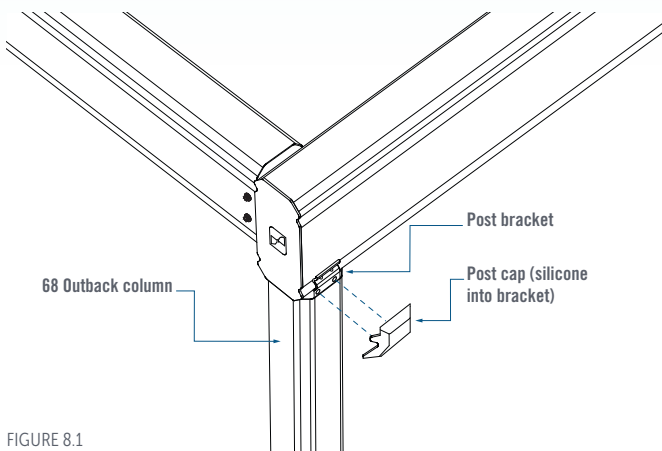

FIGURE 8.1

BEAM FILLERS

If a downpipe is to run flush with a column, place a notched beam filler over the exposed post bracket and use silicone to hold it in place (Figure 8.2).

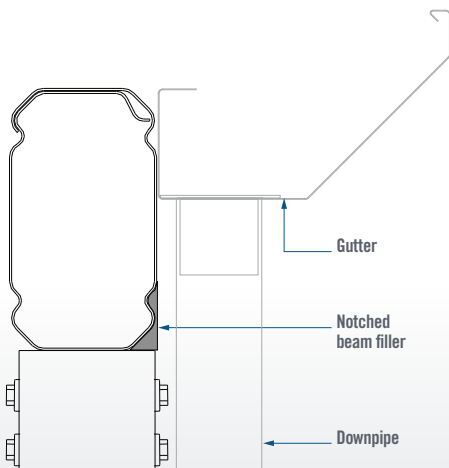

FIGURE 8.2

GUTTER ASSEMBLY

GUTTER PREPARATION

To establish the inside gutter length 'A' (Figure 8.0), measure from the back of the back channel to the outside of the front fascia and subtract 5mm for the mitre bracket. To establish the inside gutter length for units with a deck overhang, subtract 55mm from the total roof sheet length. To establish inside gutter length 'B' for the front gutter, measure the length of the front fascia beam and subtract 5mm for each mitre bracket.

Attach the stop ends to the side gutters with four rivets per stop end (Figure 9.0). Remove any swarf and waterproof with silicone.

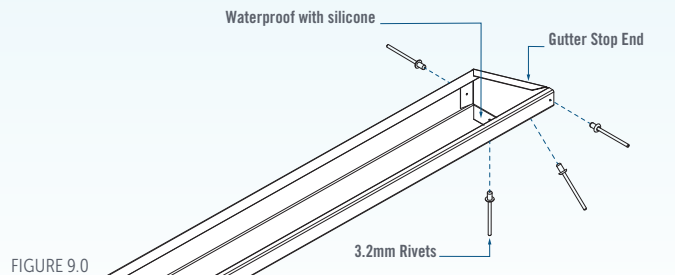

FIGURE 9.0

On the gutter ends that will form a corner, using the template provided at the back of this book, mark out and cut a 45 degree mitre (Figure 9.1). Fit the mitre brackets using 3.2mm sealed rivets to fasten the mitre to the gutter, then waterproof with silicone.

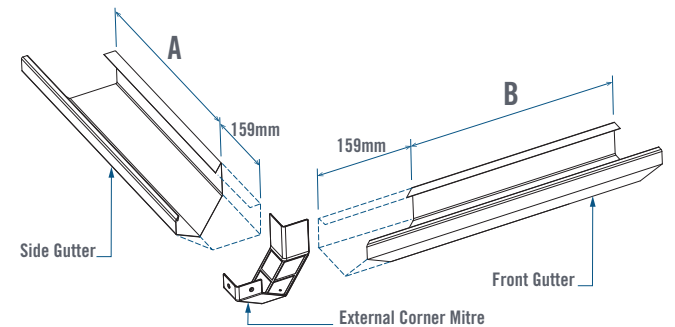

FIGURE 9.1

GUTTER OUTLET ASSEMBLY

Before attaching the gutter mark the position of the outlet. Place the downpipe in line with the column and mark and cut a 75mm diameter hole in the base of the gutter near the back edge. Insert the downpipe outlet from the inside of the gutter and waterproof with silicone (Figure 9.2).

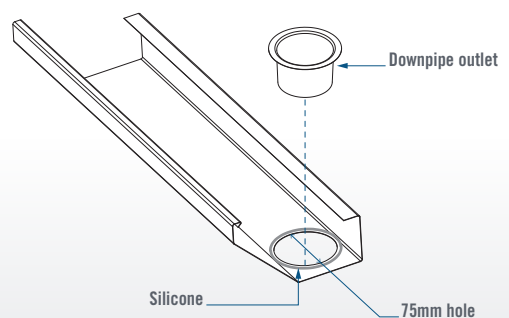

FIGURE 9.2

FIRST SIDE GUTTER ASSEMBLY

After fixing a gutter mitre bracket to the corner of the first side gutter, lift the gutter into place so the stop end slides up behind the back channel. Use rivets to fasten the gutter's back lip to the roofing at the maximum spacing of one metre (Figure 9.3). Waterproof the rivets with silicone. Ensure the front face of the gutter remains vertical and even.

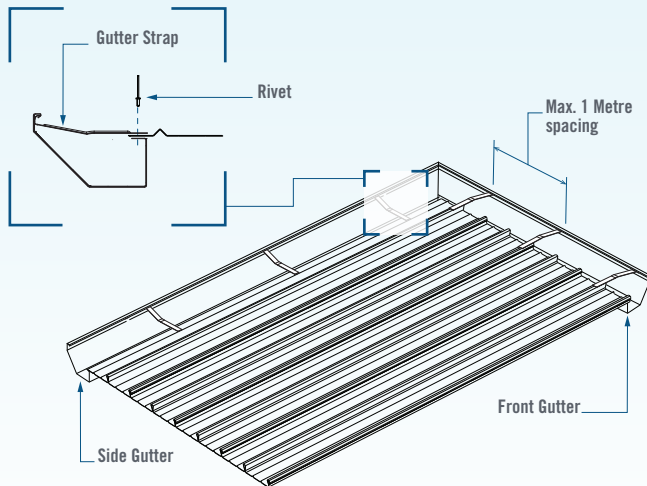

FIGURE 9.3

FRONT GUTTER ASSEMBLY

On the front gutter, attach a gutter mitre to the end opposite the side gutter. Slide the flat end of the gutter straps inside the rib of the roof sheets every metre. Hang the front gutter on the gutter straps and using a rolling action, lift the back of the gutter into the corner mitre of the side gutter. Check the roof sheets overhang into the gutter by 50mm and the gutters are square in relation to the framework. Fix the front gutter with rivets at one metre spacings through the end of the roof sheets into the gutter's back lip. For units with a deck overhang, fix the gutter to the roof sheets with two rivets per pan. Rivet and seal the front gutter to the mitre and the gutter straps to the roof sheets. Lift the final side gutter so that its front end slides into the mitre and the stop end slides up behind the back channel. Fix the gutter in position as previously described and waterproof with silicone.

DOWNPIPES

Before attaching the downpipes, rivet the downpipe brackets to the column. Slide the downpipe over the downpipe outlet and rivet into position. Rivet the downpipe to the brackets. Weatherproof all the fasteners with silicone.

FINAL FIXING

FIXING INTO THE CONCRETE FOOTING

Thoroughly check the posts with a spirit level. When plumb, fill the post hole with approximately 150mm of concrete and use a shovel or pole to agitate the concrete to remove any air pockets. Repeat this process until the hole is full, continually checking the posts as you go. The concrete must have a slight slope that runs away from the column to ensure any water does not pool around the base (Figure 10.0). Once the concrete is set remove any temporary bracing or props.

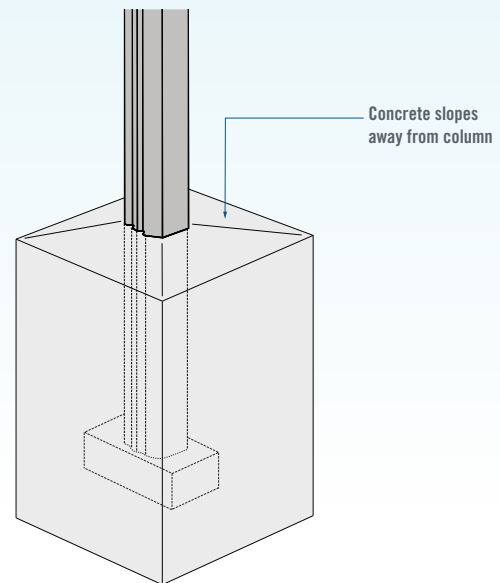

FIGURE 10.0

FIXING ONTO EXISTING CONCRETE

68 OUTBACK COLUMN

If the 68 Outback Columns are to be fixed to an existing concrete slab with a footing plate, each plate must be fixed to the concrete with two M12x75 masonry anchors or two M12x75 screwbolts (Figure 10.1).

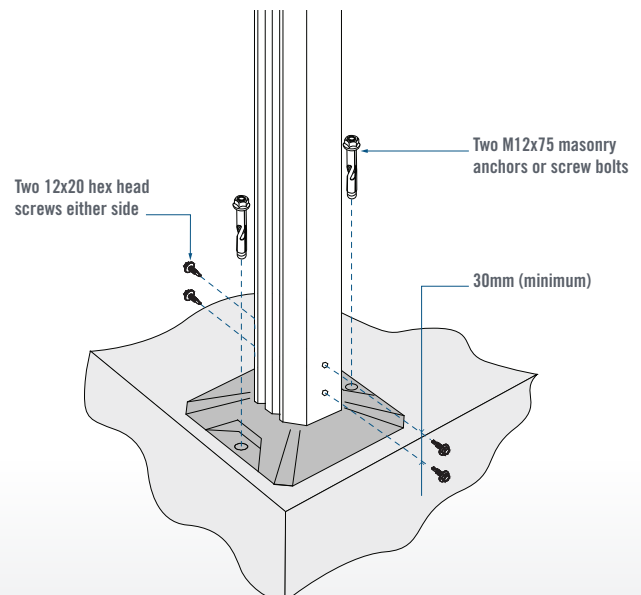

FIGURE 10.1

SHS COLUMN

If using SHS columns, the footing plate is to be fixed to the concrete slab with four M12x75 masonry anchors or screw bolts (Figure 10.2).

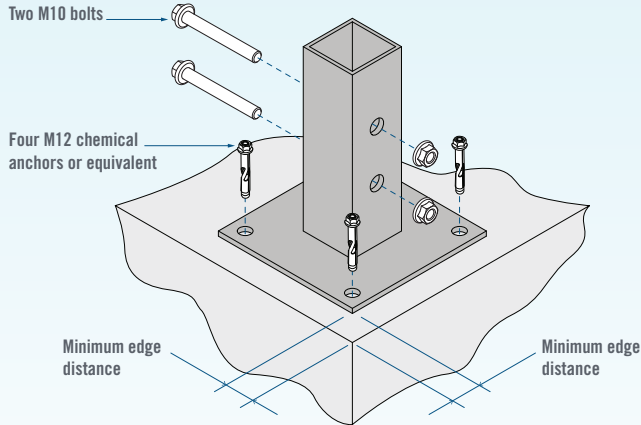

FIGURE 10.2

SHS REINFORCED OUTBACK COLUMN

Reinforced Outback Columns are to be fixed to the concrete slab with four M12x75mm masonry anchors or screw bolts (Figure 10.3).

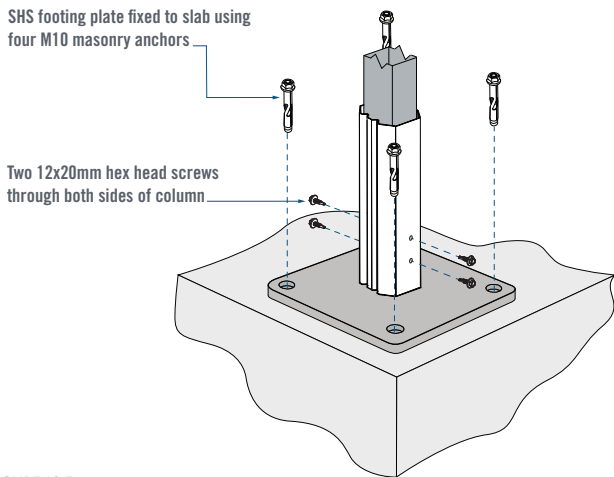

FIGURE 10.3

Note: Anchors to be installed in accordance with manufacturer's specifications with appropriate concrete edge distance as per manufacturer's requirements.

SHS INTERNAL UPSTAND

Ensure the column is plumb and mark out the footing position on the concrete. Lift the column off the internal upstand and position the upstand on the markings.

Fix the SHS internal upstand to the concrete slab using one M12 Chemical Anchor (Chemset 101 or greater) for 65mm & 75mm SHS Upstand, or two M10 Chemical Anchors (Chemset 101 or greater) for 90 & 100mm SHS Upstands (Figure 10.4).

One M12 Chemical Anchor for 65mm & 75mm Upstands (Chemset 101 or greater) or Two M10 Chemical Anchors for 90mm & 100mm Upstands (Chemset 101 or greater)

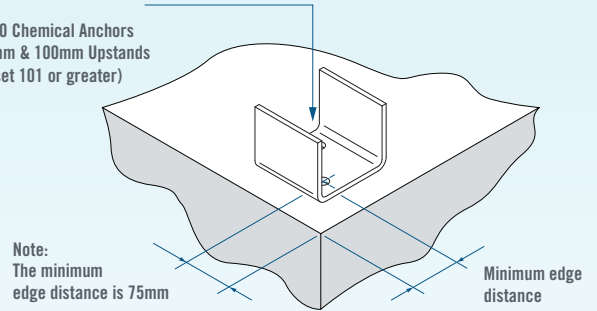

FIGURE 10.4

Position the SHS column over the Internal Upstand.

- For **65mm and 75mm SHS columns** pre-drill two 3.5mm holes through both the SHS and the Upstand legs at a minimum of 20mm spacing on each side of the column.
- For **90mm and 100mm SHS columns** pre-drill four 3.5mm holes through both the SHS and the Upstand legs at a minimum of 20mm spacing on each side of the column.

Fix the SHS to the upstand through the pre-drilled holes using 12x20mm self drilling screws (Figure 10.5).

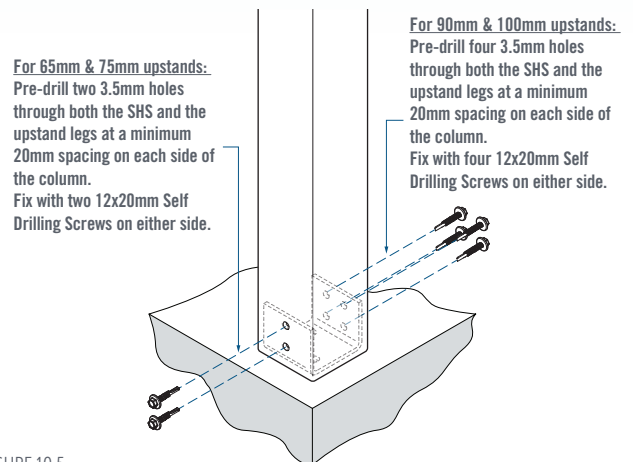

FIGURE 10.5

Seal around the base of the column with an elastic sealant. Pooling of water around the base of the column must be prevented.

IMPORTANT NOTE

Do not allow soil to remain in permanent contact with the columns as corrosion will result in the base of the column. Refer to the 'Selection, Use and Maintenance of Stratco Steel Products' brochure for complete details of the maintenance requirements.



MAINTENANCE

Regular maintenance is essential to maintain the good looks of all Stratco steel products and to ensure you receive the maximum lifespan possible. Washing with clean water must be frequent enough to prevent the accumulation of dust, salts, and pollutants that may reduce the life of the product. Stratco steel products that are regularly washed by rain require no additional maintenance. No Stratco steel structure or materials are recommended for use over, or in close proximity, to swimming pools or spas. No material that retains water (such as dirt or paving sand) should be placed against the columns. Care must be taken when determining the location of Stratco steel products so that they are not placed in close contact with sources of pollution or environmental factors that could affect the life of the steel. Refer to the 'Selection, Use and Maintenance' brochure for more information.



« SCAN THIS QR CODE TO FIND A STRATCO NEAR YOU

1300 155 155
stratco.com.au

All brands and logos/images accompanied by ® or ™ are trade marks of Stratco (Australia) Pty Limited. © Copyright November 2021

How To.



EDGE 160 EXTERNAL MITRE FLAT PATTERN TEMPLATE

CUT-OUT TEMPLATE FOR MARKING-UP GUTTERS

FLIP TEMPLATE FOR LEFT & RIGHT VARIATIONS

ENSURE TEMPLATES ARE PRINTED AT "ACTUAL SIZE"

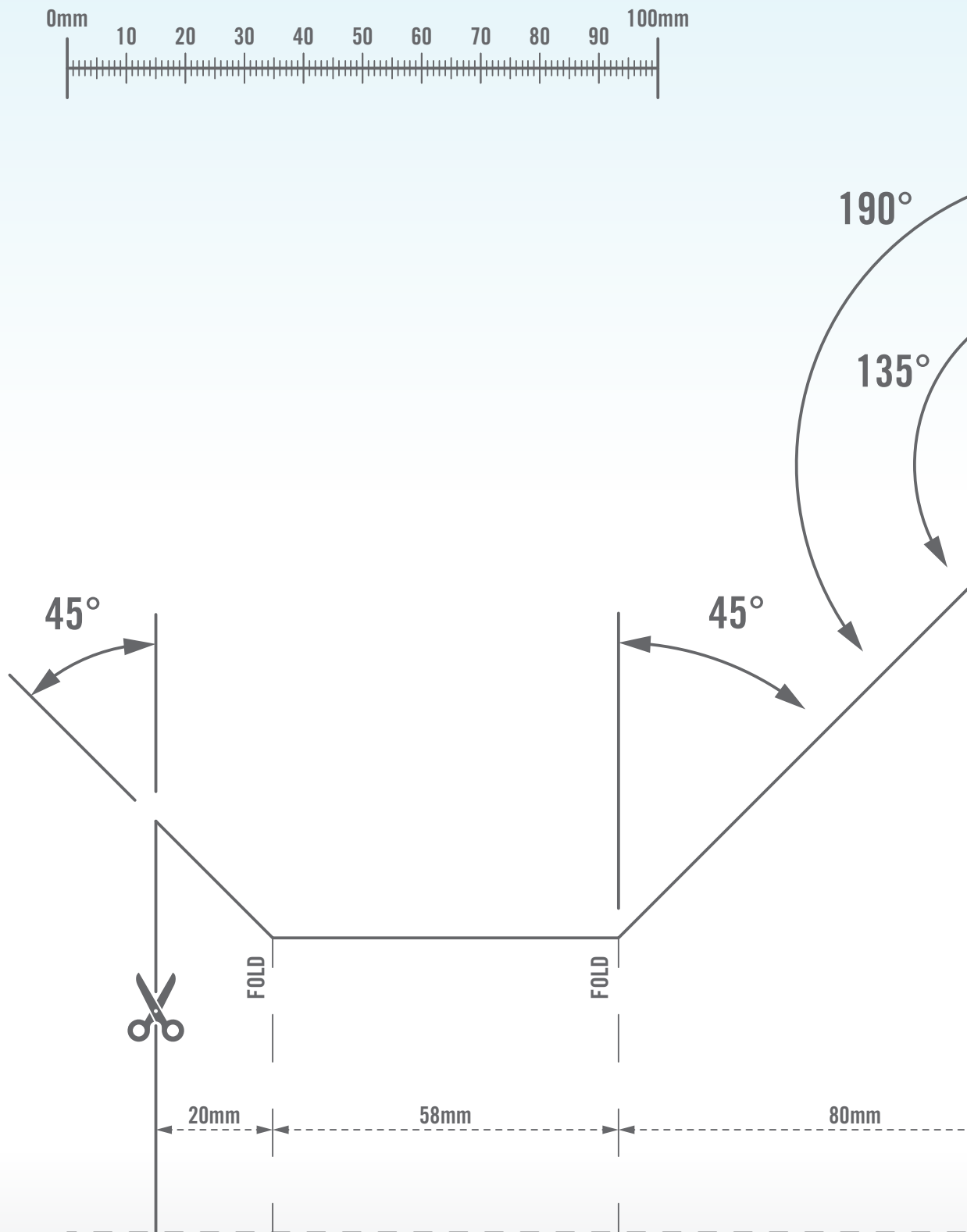

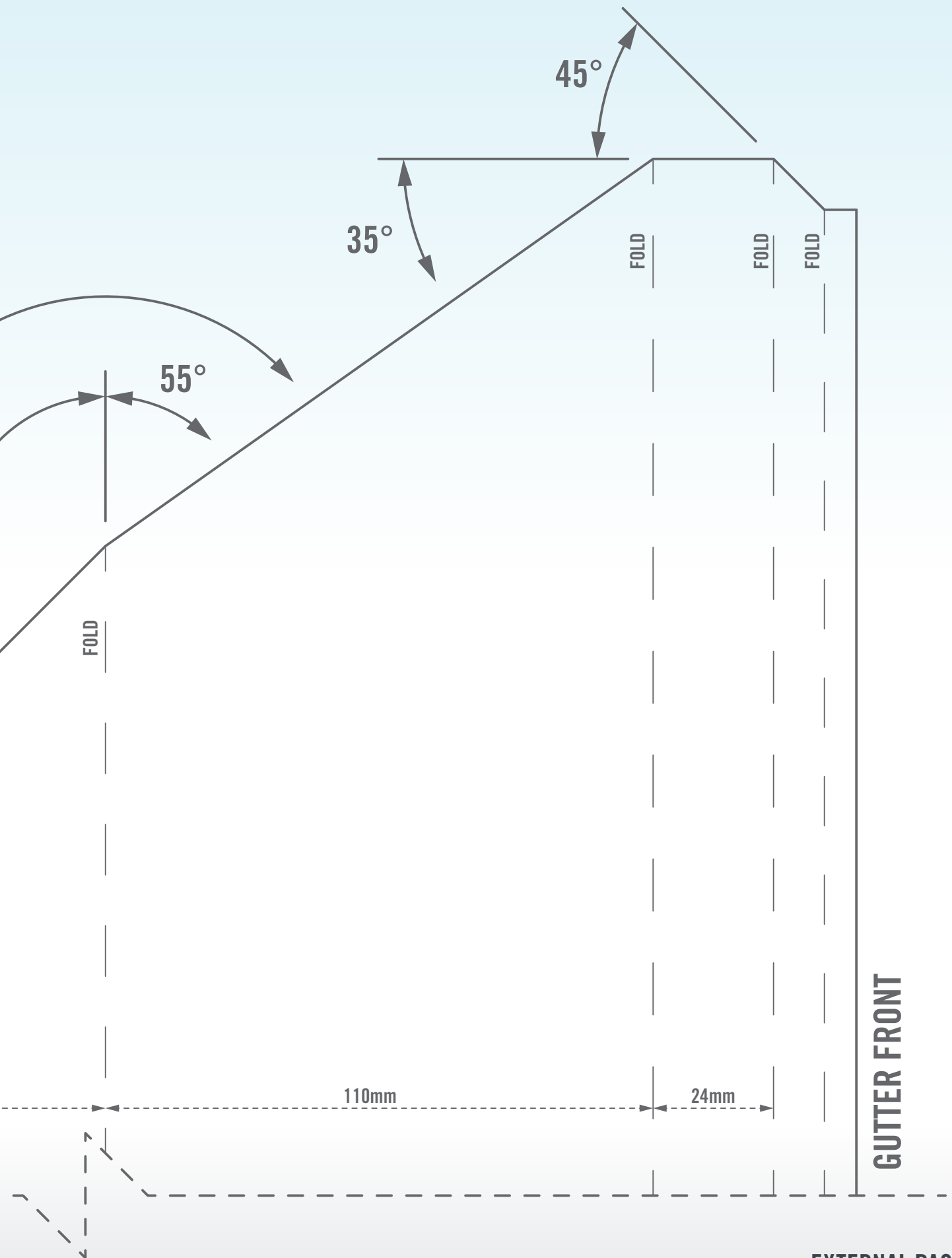

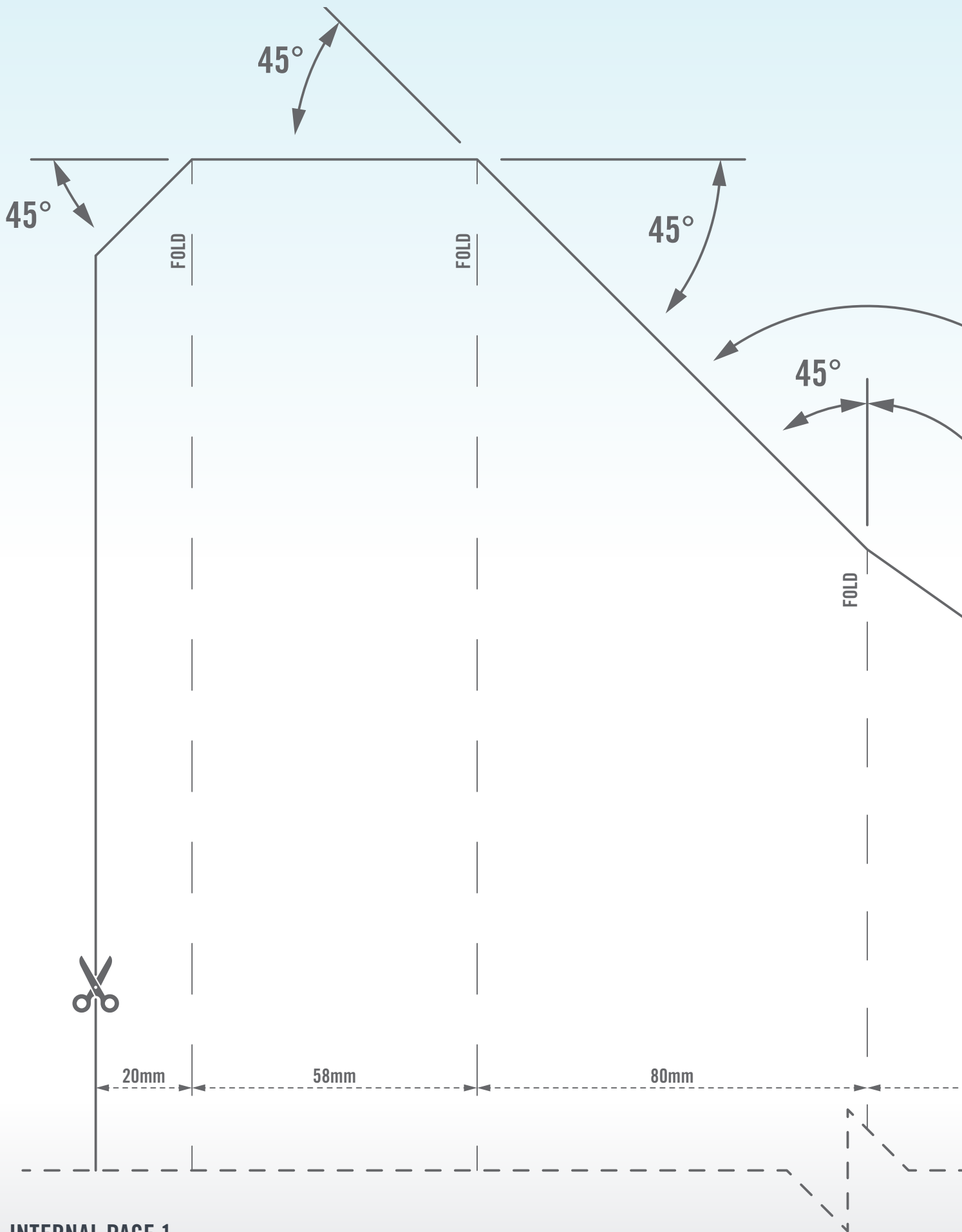

EDGE 160 INTERNAL MITRE FLAT PATTERN TEMPLATE

CUT-OUT TEMPLATE FOR MARKING-UP GUTTERS

FLIP TEMPLATE FOR LEFT & RIGHT VARIATIONS

ENSURE TEMPLATES ARE PRINTED AT "ACTUAL SIZE"

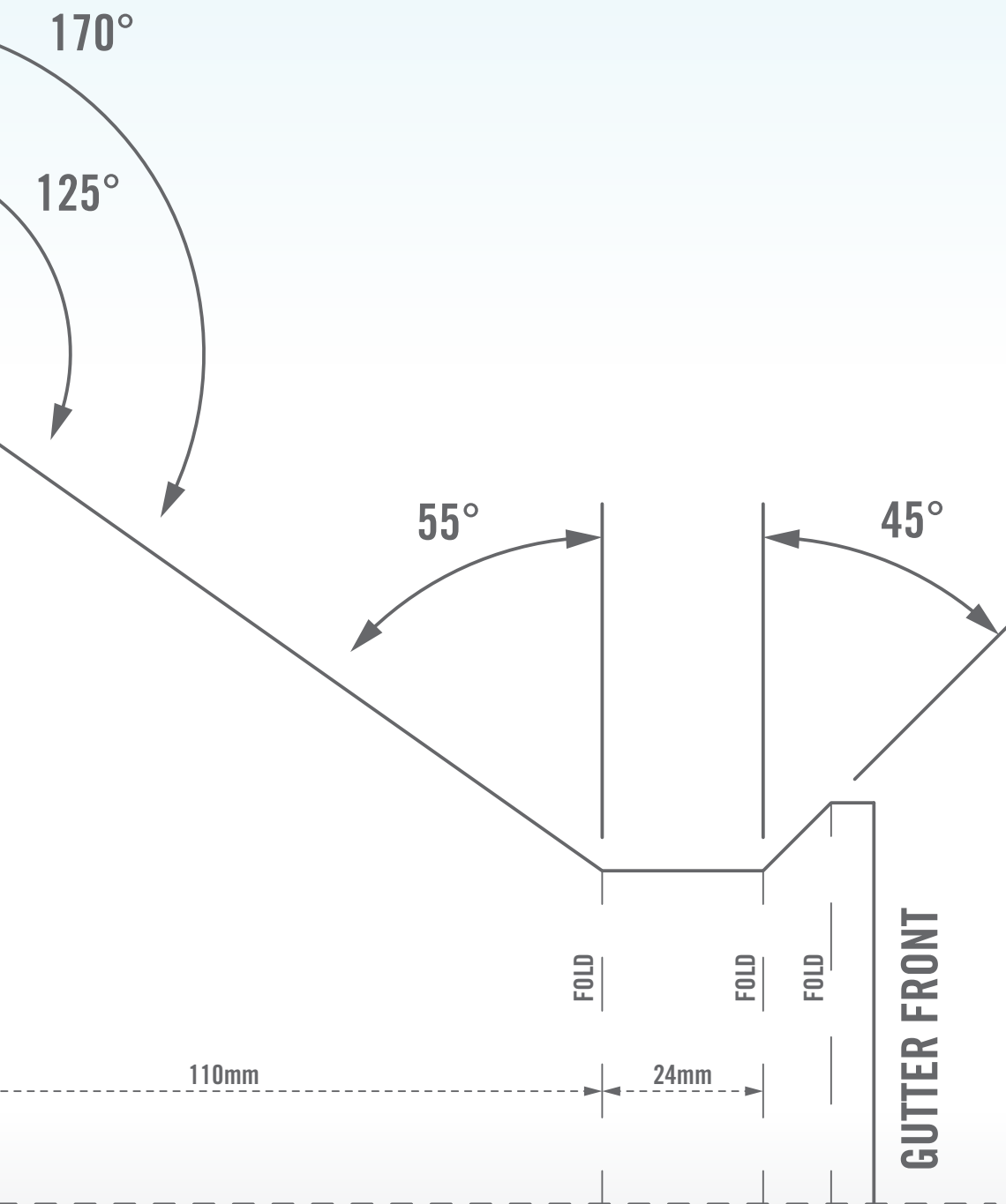

EDGE 160 135° EXTERNAL MITRE FLAT PATTERN TEMPLATE (A)

CUT-OUT TEMPLATE FOR MARKING-UP GUTTERS

FLIP TEMPLATE FOR LEFT & RIGHT VARIATIONS

ENSURE TEMPLATES ARE PRINTED AT "ACTUAL SIZE"

PAIR BELOW TEMPLATE (135° EXTERNAL A) WITH 135° EXTERNAL B (SEE OVER)

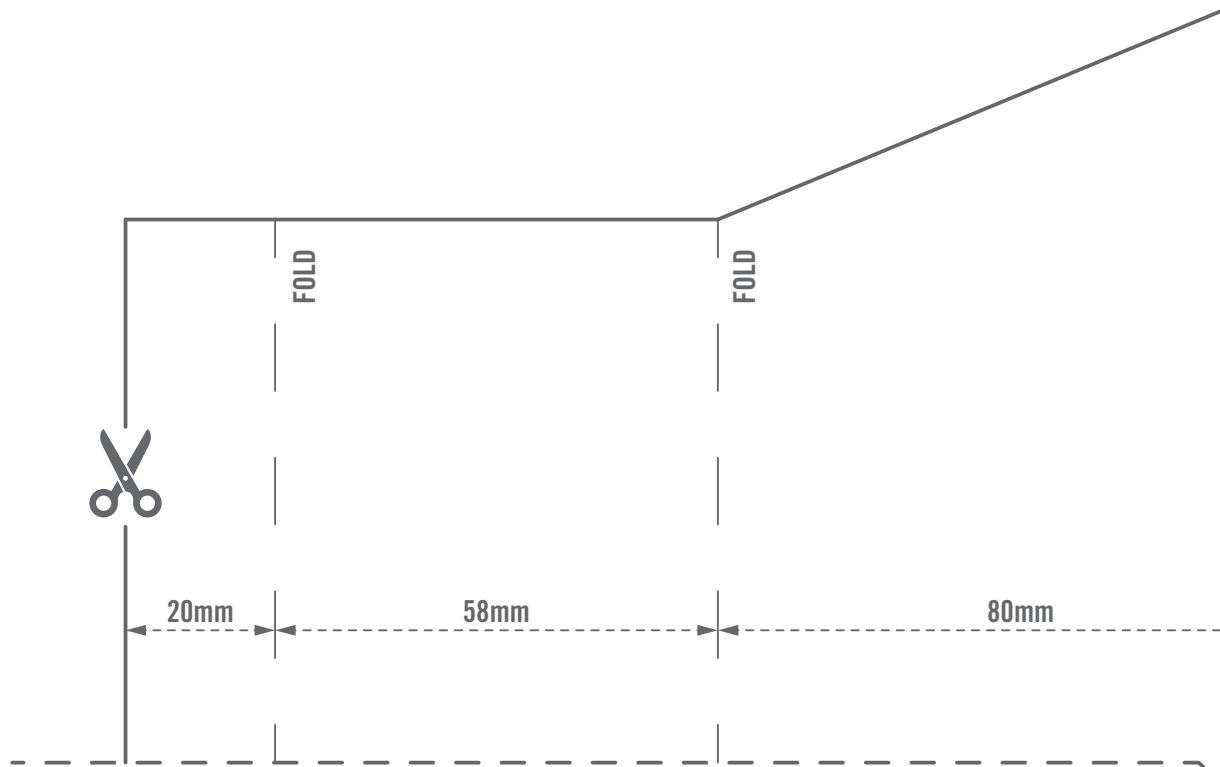
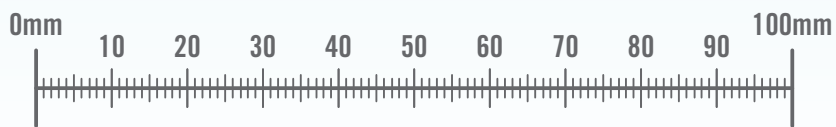

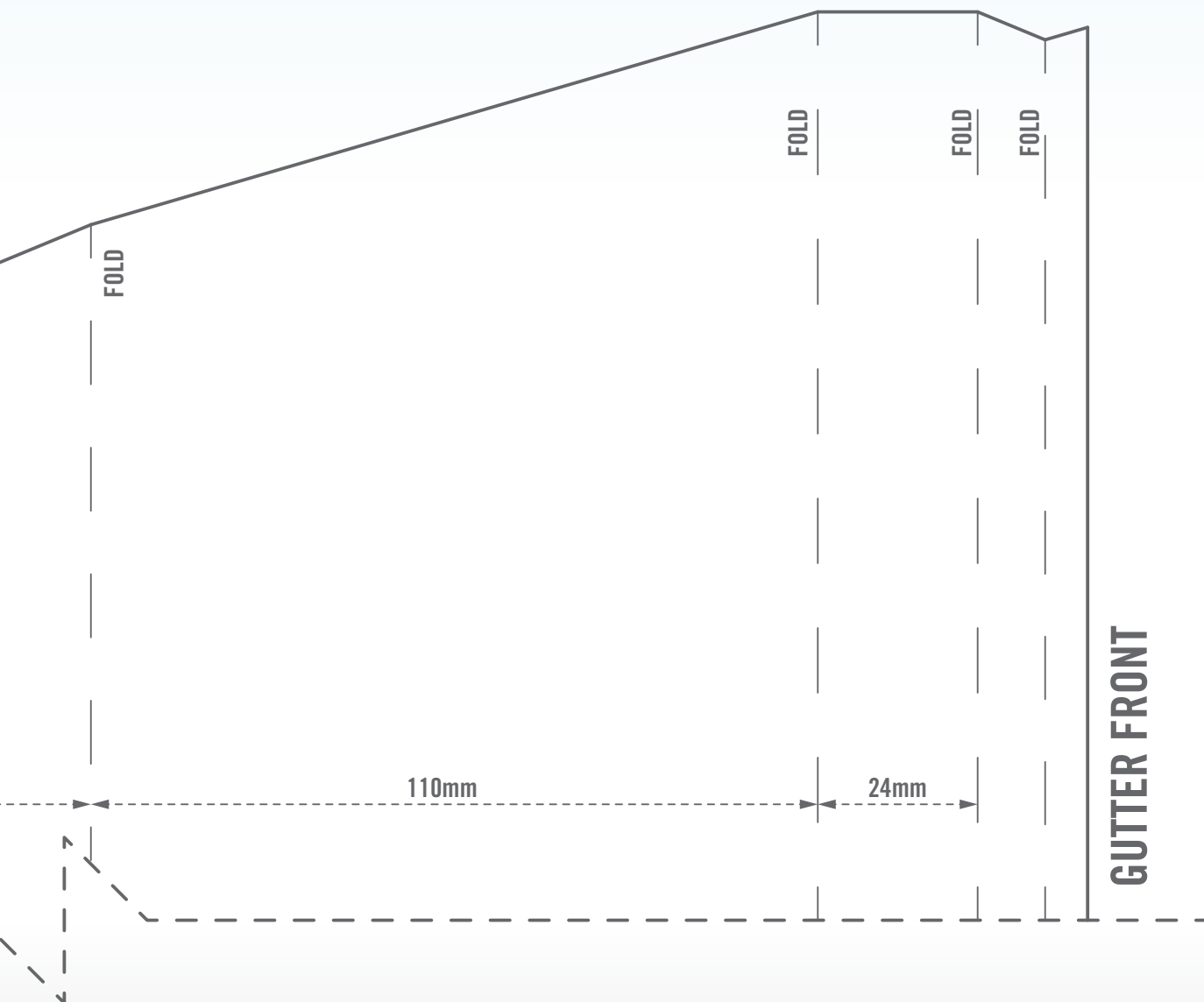
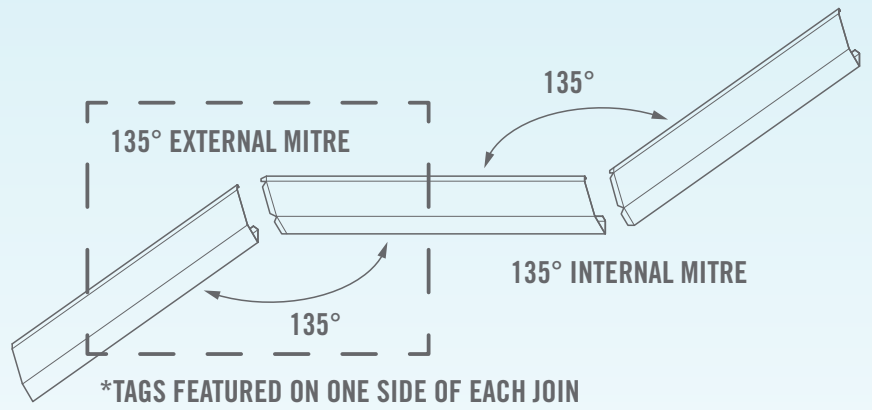

EDGE 160 135° EXTERNAL MITRE FLAT PATTERN TEMPLATE (B) (WITH TAGS)

CUT-OUT TEMPLATE FOR MARKING-UP GUTTERS

FLIP TEMPLATE FOR LEFT & RIGHT VARIATIONS

ENSURE TEMPLATES ARE PRINTED AT "ACTUAL SIZE"

PAIR BELOW TEMPLATE (135° EXTERNAL B) WITH 135° EXTERNAL A

FOLD TAGS TO FEED INSIDE ADJOINING GUTTER

RIVET MITRE SIDE A TO THE INTERNAL TAGS OF MITRE SIDE B ONCE NEATLY JOINED

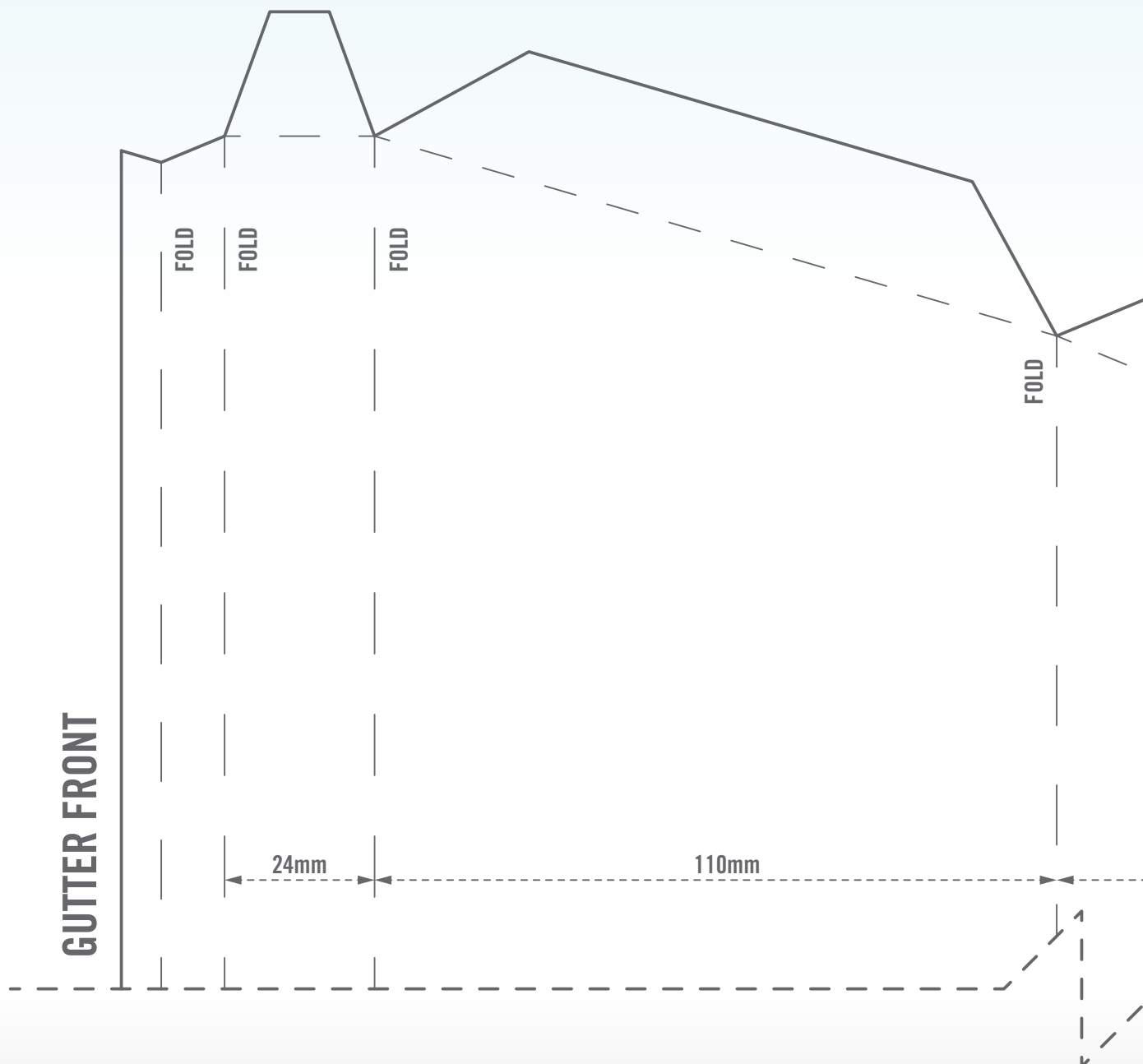

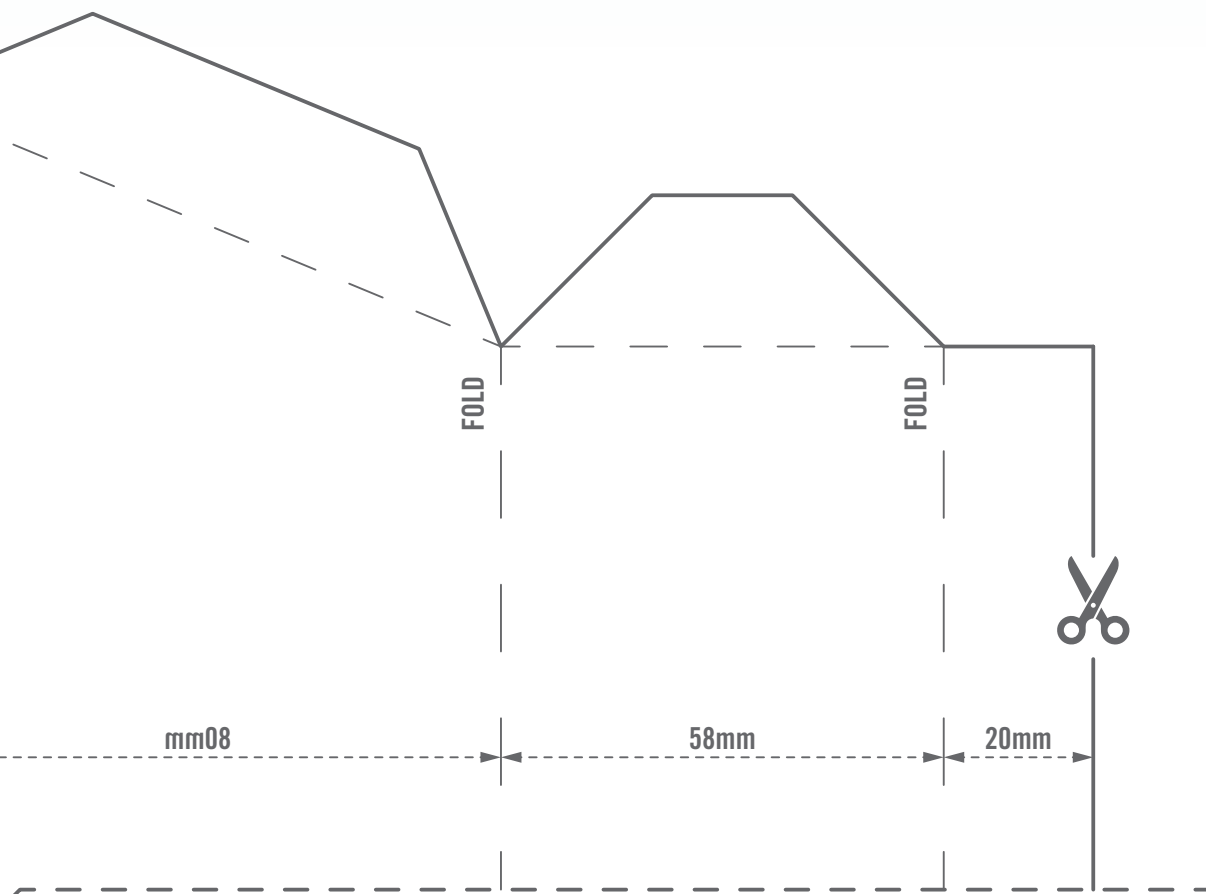
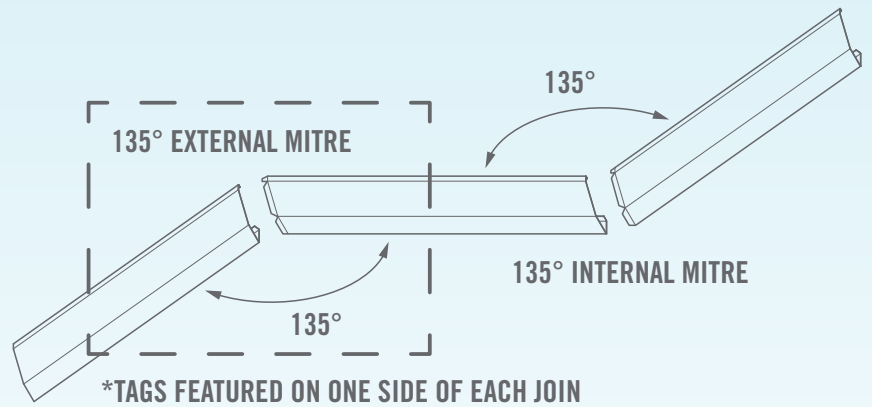

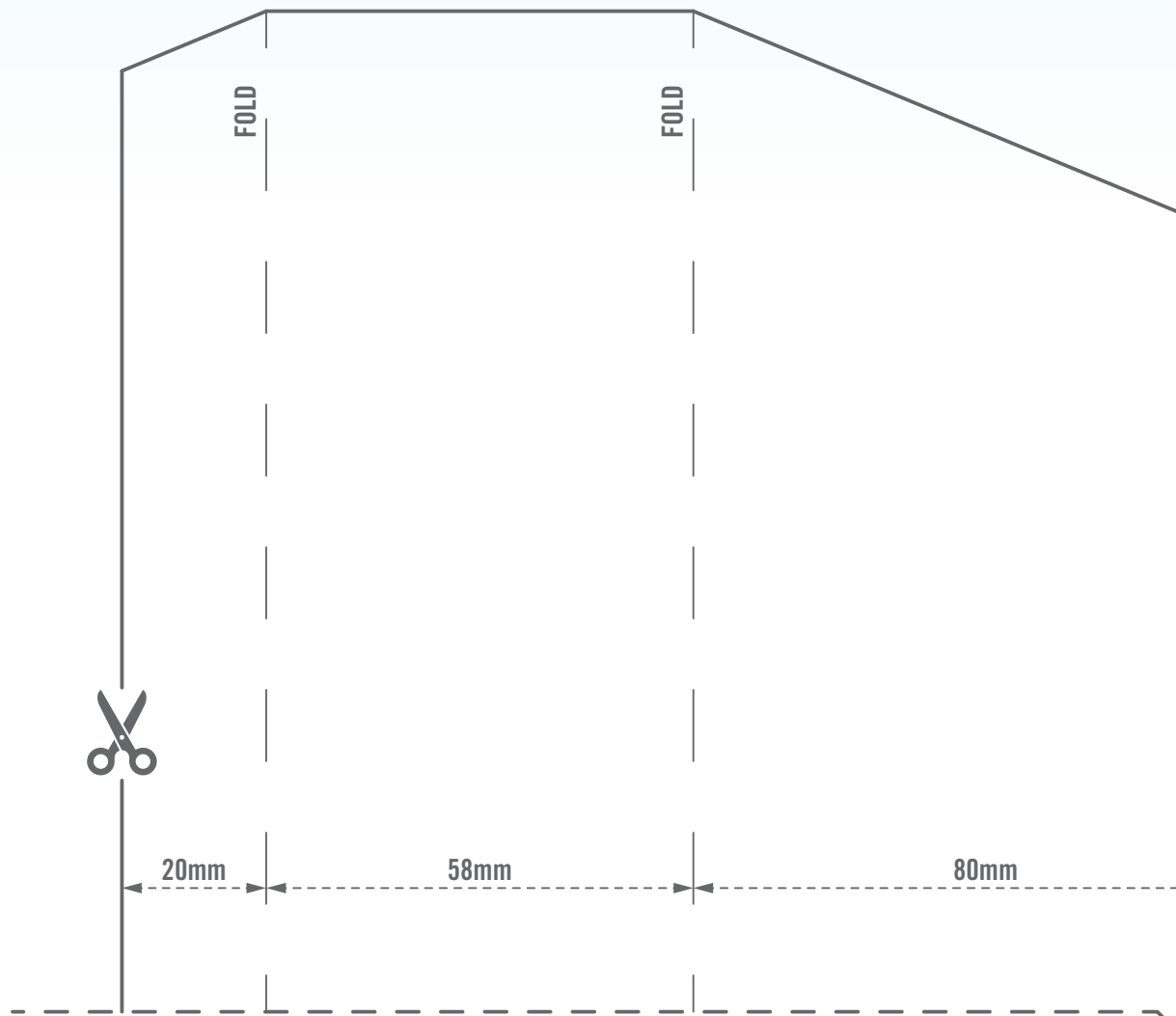
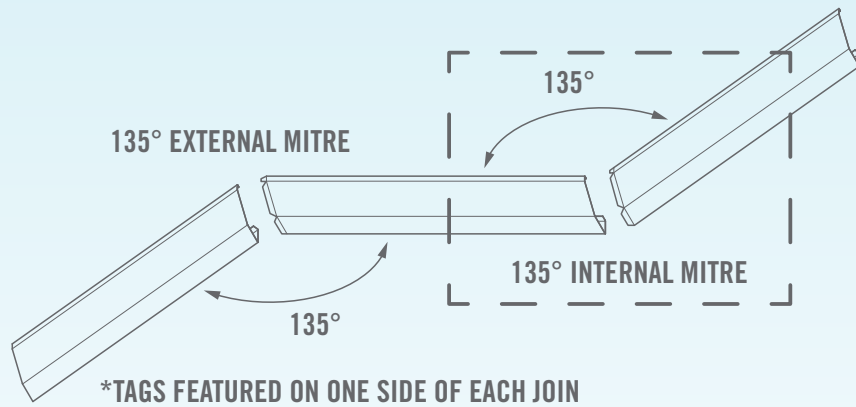

EDGE 160 135° INTERNAL MITRE FLAT PATTERN TEMPLATE (A)

CUT-OUT TEMPLATE FOR MARKING-UP GUTTERS

FLIP TEMPLATE FOR LEFT & RIGHT VARIATIONS

ENSURE TEMPLATES ARE PRINTED AT "ACTUAL SIZE"

PAIR BELOW TEMPLATE (135° INTERNAL A) WITH 135° INTERNAL B (SEE OVER)

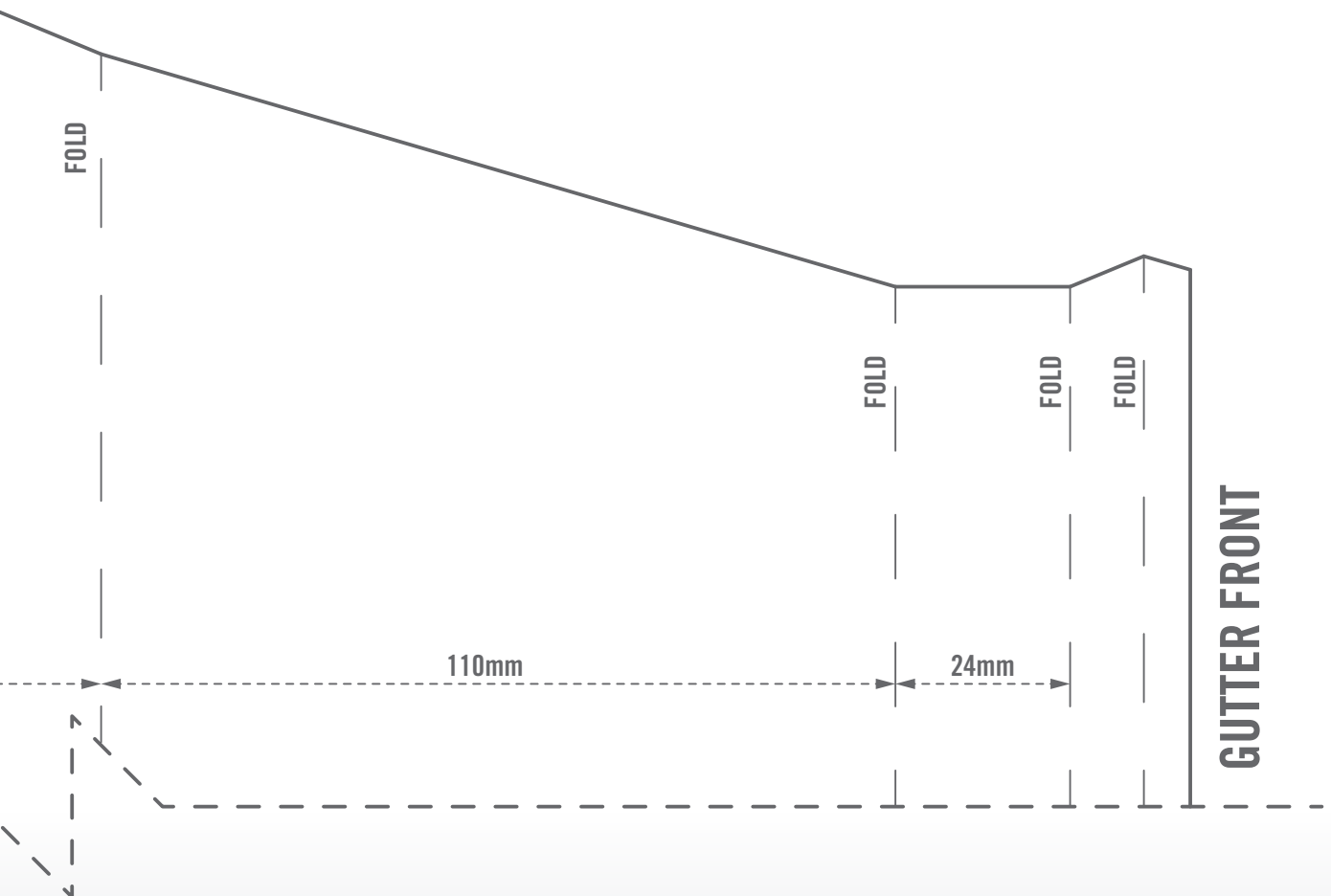
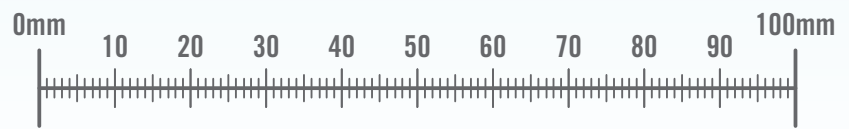

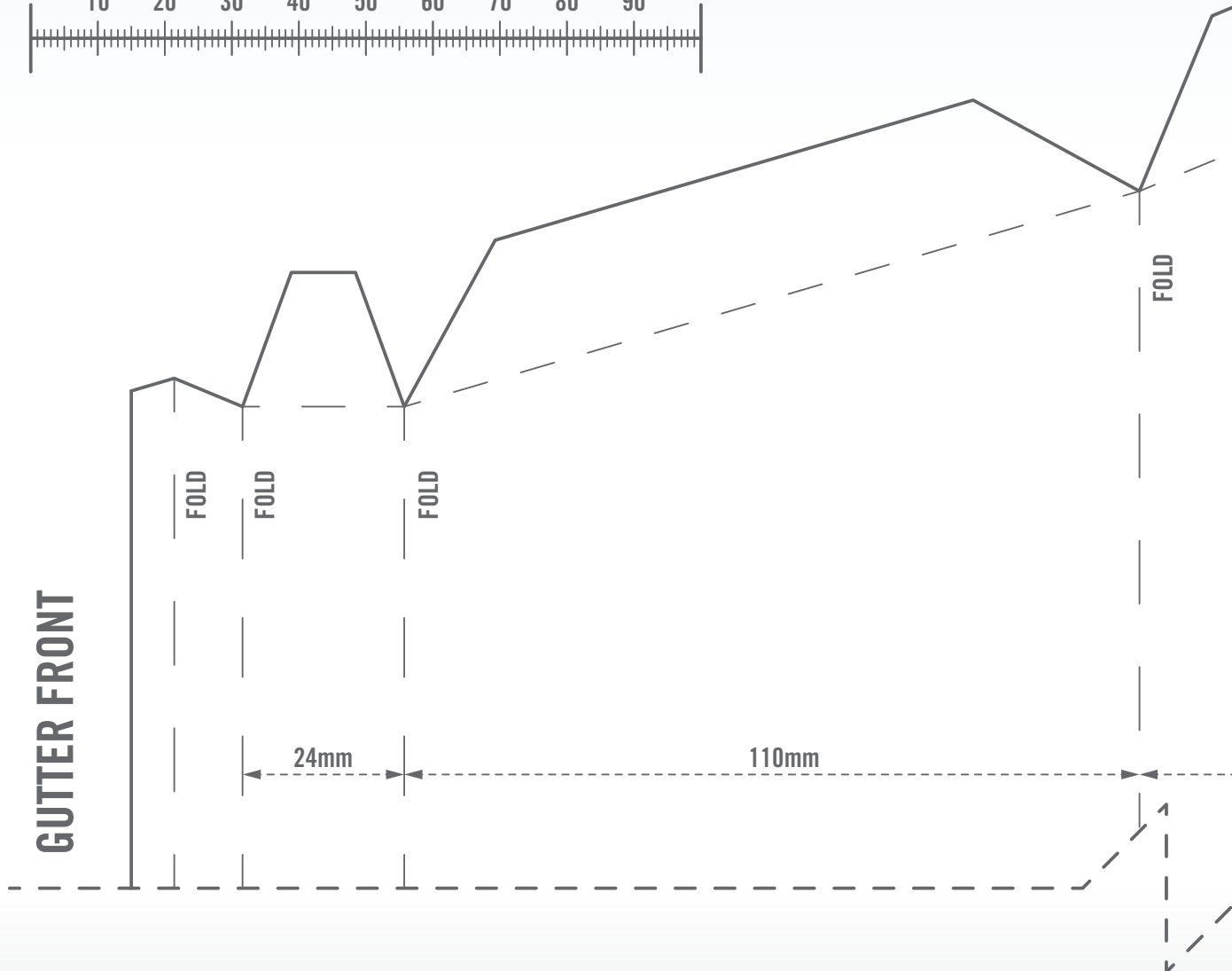
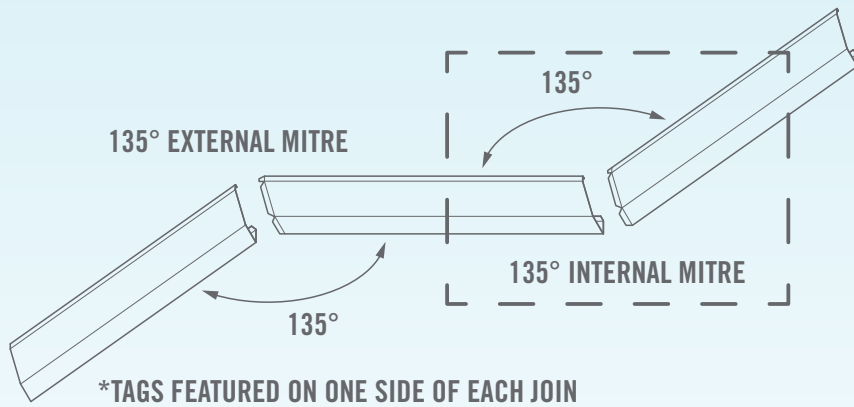

EDGE 160 135° INTERNAL MITRE FLAT PATTERN TEMPLATE (B) (WITH TAGS)

CUT-OUT TEMPLATE FOR MARKING-UP GUTTERS

FLIP TEMPLATE FOR LEFT & RIGHT VARIATIONS

ENSURE TEMPLATES ARE PRINTED AT "ACTUAL SIZE"

PAIR BELOW TEMPLATE (135° INTERNAL B) WITH 135° INTERNAL A

FOLD TAGS TO FEED INSIDE ADJOINING GUTTER

RIVET MITRE SIDE A TO THE INTERNAL TAGS OF MITRE SIDE B ONCE NEATLY JOINED

