

CLEARSPAN GABLE WITH HIP END ATTACHED PATIO

STRATCO OUTBACK® ASSEMBLY INSTRUCTIONS.

Your supplementary guide to building an ATTACHED CLEARSPAN GABLE VERANDAH or PATIO WITH HIP END



This set of instructions should be used in conjunction with the Stratco instruction brochure 'Flat Verandahs Attached - Your complete guide to building an Attached Outback® Verandah, Patio or Carport'.

BEFORE YOU START

Carefully read these instructions, along with the Stratco Flat Verandahs Attached Instructions. If you do not have all the necessary tools or information, contact Stratco for advice. Before starting lay out all components and check them against the delivery docket. The parts description identifies additional gable parts, and the component layout diagram indicates their fastening position.



RIDGE KNUCKLE
Slots inside the gable rafters to form connection at the ridge.

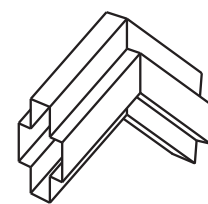

RAFTERS
Gable Rafters consist of pre-cut 120 Outback® beam.

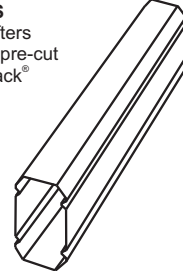

RAFTER TO VALLEY BRACKET
This bracket fastens the rafter to the valley beam.

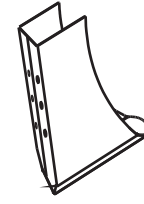

SPACERS
Are used to prevent the 150 attachment beam from crushing.

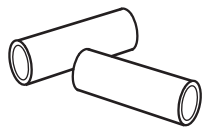

SOAKER FLASHING
The soaker flashing water proofs the rear of the gable and conceals the existing house gutter.

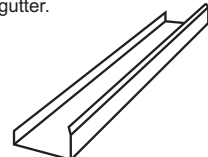

BEAM CAPPING
Fixed to top of the valley beam to provide support for outback deck.

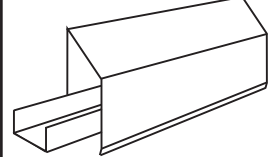

END STRUT
The gable infill is supported by the end strut, which consists of a section of post.

22° or 30° END STRUT PLATE
Secures the end strut at the ridge.



HEADER BEAM BRACKET
Connects end strut to header beam on an infill gable.

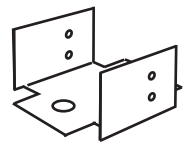

RIDGE CAP
This flashing covers the roof sheets at the gable ridge and the Gazebo End hips.

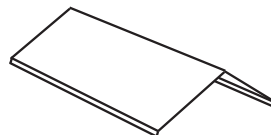

BARGE CAP
The barge cap covers the area where the deck finishes at portal frame.

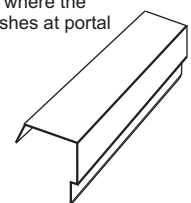

SCREWS AND RIVETS
Fastener types vary depending upon the connection, ensure correct fixings are used.

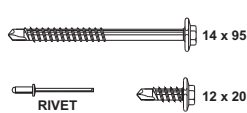

BOLTS
Fastener types vary depending upon the connection, ensure correct fixings are used.

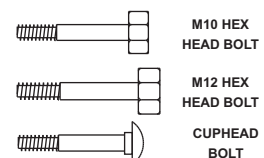

PERIMETER BRACKET
This bracket fastens the rafters to the hip fascia beam.

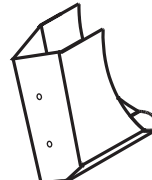

GABLE BEAM BRACKET
Connects rafters to header beam on an infill gable.

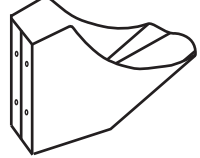

TWO PIECE CLEARSPAN BACK CHANNEL
Secures deck over hip rafters.

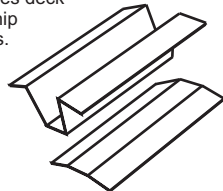

BEAM TO BEAM BRACKET
Connects horizontal beams.

BEAM FILLER
Fills gap between intersecting beams.

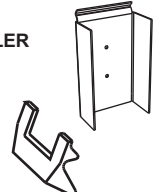

HIP END BEAM CAPPING MITRE
Covers the gap at the Beam Capping intersection.

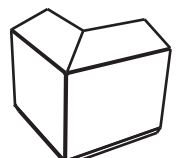

HEADER FLASHINGS
Runs along header beam to neatly finish the base of infill panels.

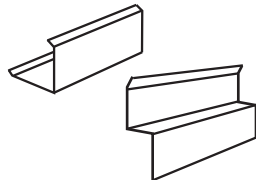

APEX BRACKET
This bracket fastens the hip rafters to the apex of the gable frame.

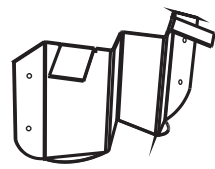

POST BRACKET
Connects post to beam.

POST CAP
Fills gap between post and beam.

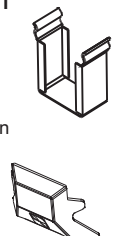

PANEL STRIPS
Decorative strips fixed to infill panels.

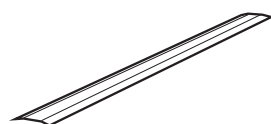

INFILL PANEL
Cut to suit gable end frames.

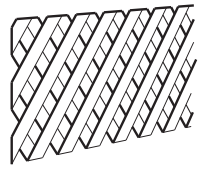

FINIAL
Provides decoration at the apex of the gable end frame.

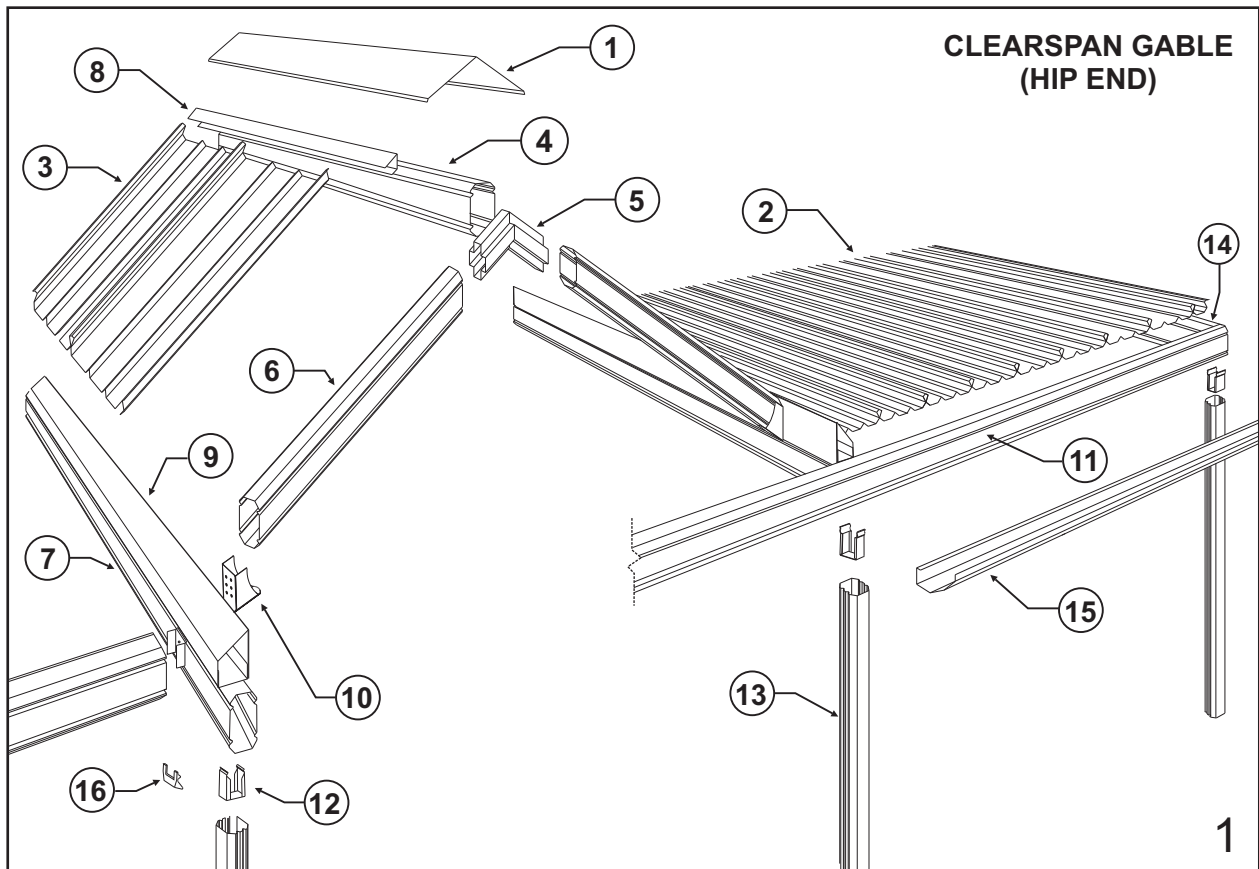

- | | |
|-----------------------|----------------------------|
| ① Ridge Cap | ⑩ Rafter to Valley Bracket |
| ② Flat Section | ⑪ Front Fascia Beam |
| ③ Outback® Deck | ⑫ Post Bracket |
| ④ Ridge Beam | ⑬ Post |
| ⑤ Ridge knuckle | ⑭ End Fascia Beam |
| ⑥ Gable Rafter | ⑮ Gutter |
| ⑦ Valley Beam | ⑯ Notched Beam Filler |
| ⑧ Angled Back Channel | |
| ⑨ Beam Capping | |

HIP END

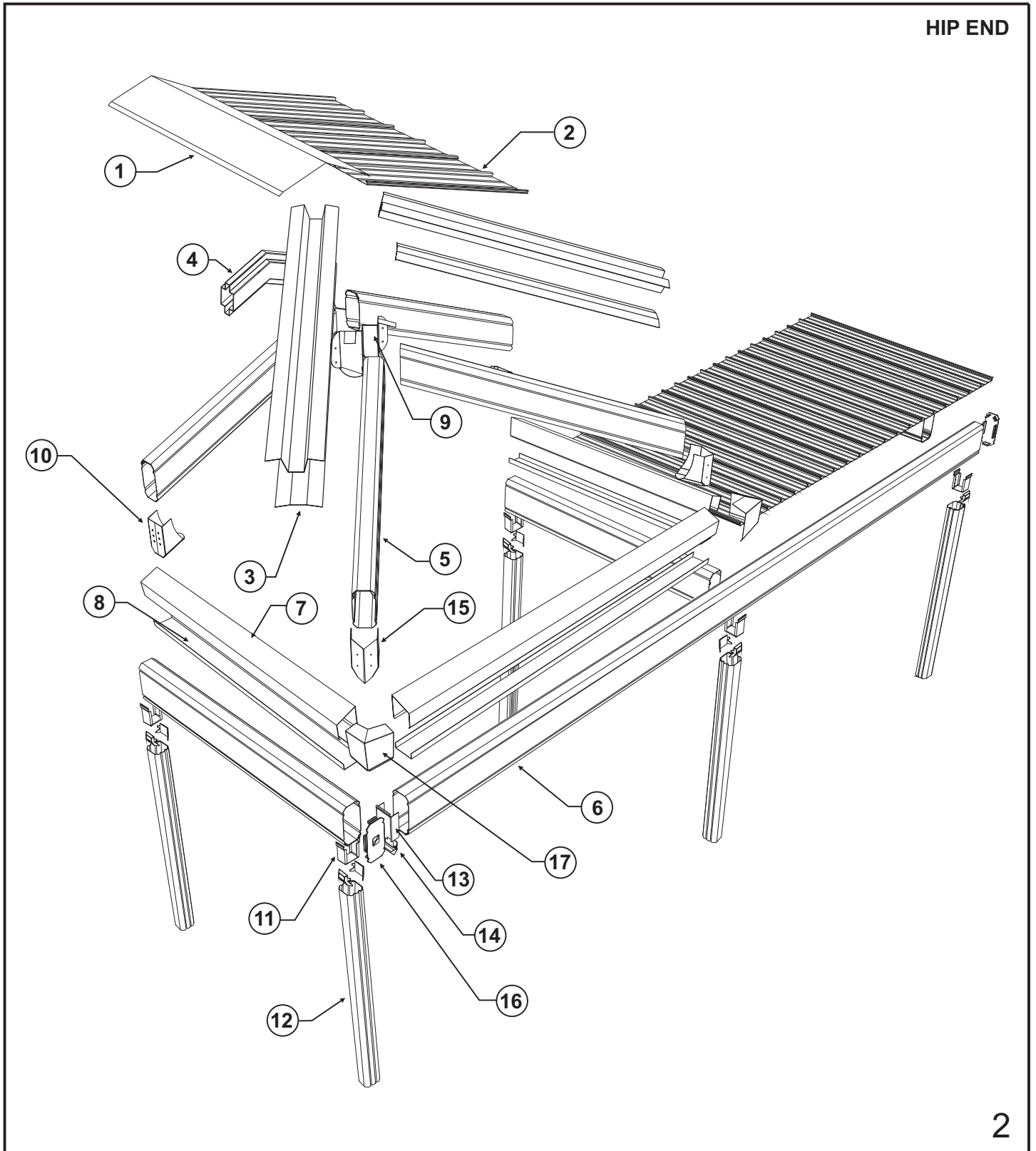

2

- | | |
|------------------------------------|------------------------------|
| ① Ridge Cap | ⑩ Rafter to Valley Bracket |
| ② Outback® Deck | ⑪ Post Bracket |
| ③ Two Piece Clearspan Back Channel | ⑫ Post |
| ④ Ridge Knuckle | ⑬ Beam to Beam Bracket |
| ⑤ Hip Rafter | ⑭ Notched Beam Filler |
| ⑥ Hip Fascia Beam | ⑮ Perimeter Bracket |
| ⑦ Beam Capping | ⑯ Beam End Cap |
| ⑧ Beam Channel | ⑰ Hip End Beam Capping Mitre |
| ⑨ Hip Apex Bracket | |

These materials are needed to complete the job, but are not included in the basic kit price. (they must be purchased as extra items, and their quantities specified):

- Rafter strengthening brackets and channels to suit 150 beam attachment for attaching gable to house.
- M12 bolts and nuts for fixing strengthening brackets to the rafter.
- M12 bolts and nuts for fixing 150 attachment beam to strengthening brackets.
- Fascia Brackets for attaching gable on end to house.
- M10 coach bolts and nuts for fixing fascia brackets to the house rafter.
- M8 masonry anchors for fixing Wall Brackets to masonry.

- 12x25 type 17 teks for fixing Suspension Brackets to timber.
- 12x20 hex head screws for fixing Suspension Brackets to steel fascia.
- Cover flashings (measurements required).
- Box gutter (measurements required).

OPTIONAL EXTRAS

- These items are available at request:
- Infill Panels
 - Panel Strips
 - Finial
 - Soaker Flashing in lieu of Header Flashing
 - Purlin Intersection Cap

1.0 INTRODUCTION

Please read these assembly instructions thoroughly before commencing the construction. Double check all dimensions, levels and bolting locations before cutting, screwing or bolting structural members. It is recommended that the persons erecting the structure have had some previous building experience, because some modifications to the existing house structure are required.

2.0 ATTACHING TO AN EXISTING STRUCTURE

The builder or council is to ensure the existing house/structure is of a suitable structural integrity and complies with all the relevant Australian Building codes and standards. For more information regarding the suitability of the house structure to accommodate the Stratco Attached Clearspan Gable, consult a structural engineer or a building authority. It is the builders responsibility to ensure that the existing house roof structure is strengthened correctly.

Refer to section 2.1 if attaching Clearspan Gable on it's side to a house, section 2.2 if attaching on it's end to a house or refer to both sections if attaching the gable on it's side and end.

2.1 ATTACHING ON SIDE TO HOUSE

A Stratco Clearspan attached on it's side to a house is attached to the existing eaves overhang at the fascia.

The first objective in the construction is to fix a structural side beam along the fascia or wall, to which the Gable Unit is attached.

Most existing houses have not been designed for the attachment of portal framed gables to their side, therefore additional strengthening of the house rafters must be performed.

In order to strengthen the existing house rafters, the roof tiles or roof sheets need to be lifted, to expose the roof frame. Steel rafter brackets and channels are then bolted along the house rafters. Refer to section 2.1.1.

A 150 mm Outback® beam is bolted to the strengthening brackets at the fascia. Once the 150 attachment beam is secured to the house the Gable Unit can be erected and fastened to the beam.

2.1.1 RAFTER STRENGTHENING

The first step is to determine the number of rafters which need to be strengthened, and their location relative to the unit. You will have to lift some roof tiles or roof sheets to discover the rafter positions and spacings. The number of rafters which need to be strengthened is determined by the builder.

Note: It is the builders responsibility to ensure the existing rafters and fascia are adequately reinforced and strengthened to accommodate any additional attached structure. The reinforcing method must be approved by the appropriate council and engineer.

Use an adjustable rafter strengthening bracket and one channel for eaves overhangs up to 450 mm. Use an adjustable rafter strengthening bracket and two channels for eaves overhangs over 450 mm and up to and including 600 mm, as shown in figure 4.

The adjustable rafter strengthening bracket is shown in Figure 3. Please note that this bracket may not be suitable for applications where the front face of the house gutter is higher than 120 mm. In these cases please contact Stratco for alternative solutions.

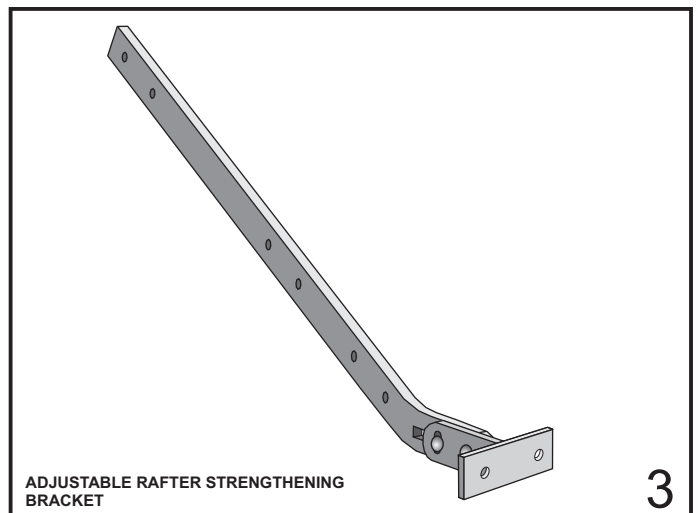

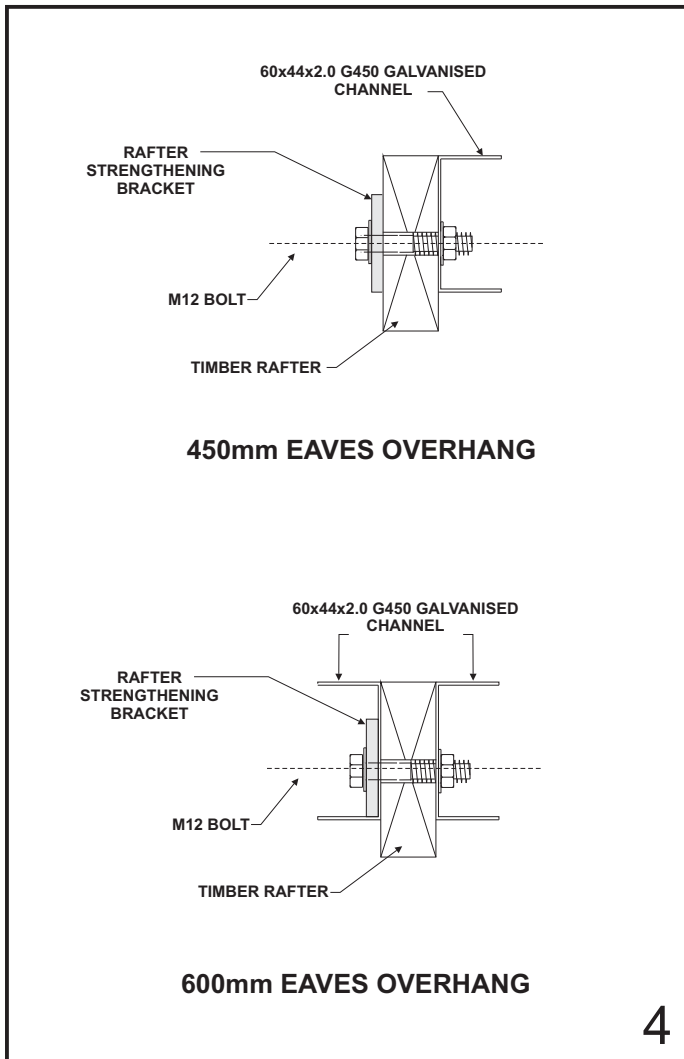

Fixing Rafter Strengthening Brackets and Channels

The adjustable rafter strengthening bracket allows for an adjustment of pitch in the range of 15 to 30 degrees. The distance the bracket extends past the fascia is also adjustable to allow for standard gutters or box gutters with a width of up to 200mm.

In conjunction with rafter strengthening brackets, channels are fixed to the side of the house rafter (Figure 4). The bottom end of the channel will be located at the base of the house rafter. Holes should be marked and pre-drilled in the channels to suit the location of existing holes in the bracket. The channel will extend beyond the bracket so additional holes are to be drilled in the channel at approximately 500mm centres.

Initially the bracket T piece shall be fixed to the bracket arm with two M12 cup head bolts (hand tighten only), a spring washer is to be located between the standard M12 washer and nut (Figure 5). Mark the position of the bracket on the fascia and notch a rectangular hole in the fascia allowing the bracket to be fed through the front of the fascia. The hole may need to be enlarged slightly if the M12 cup head bolts interfere with the fascia.

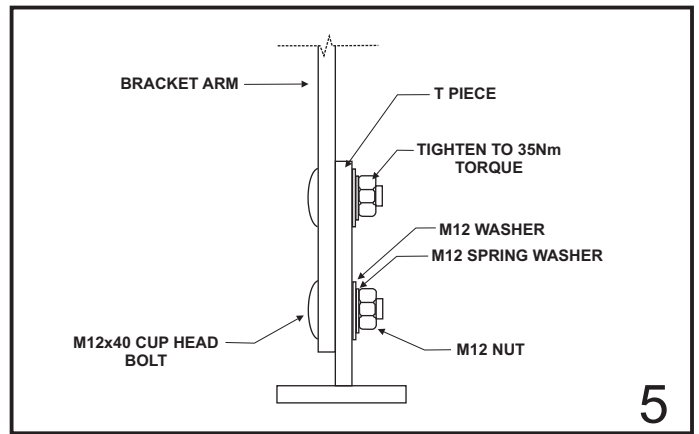

Insert the bracket through the fascia and fix with the channel(s) to the house rafter using M12 hex head bolts through the existing holes in the bracket and further up the channel(s) (Figure 7). Adjust the T piece so it is horizontal and has the appropriate extension past the fascia to allow for fixing of the attachment beam. T piece connection bolts are to be tightened to a minimum 35Nm torque.

Fix the bracket as close to the base of the gutter as possible (recommended distance 10mm from lowest end of gutter), as shown in figure 6.

The 150 attachment beam is to be fixed to the end plate to ensure the carport roof sheets drain into the existing house gutter (Figure 6).

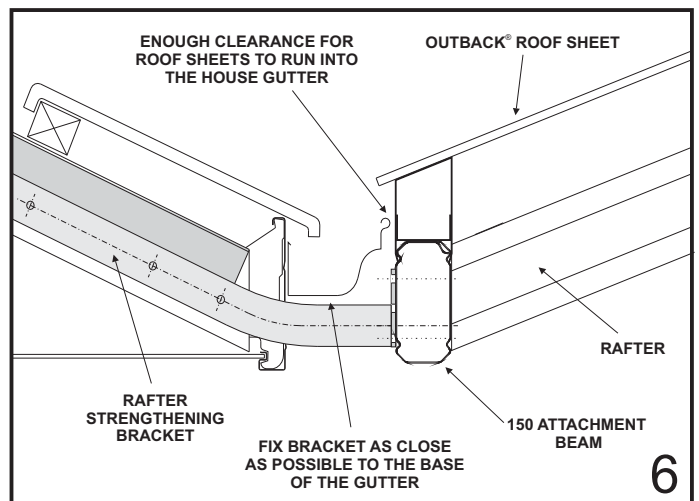

Fixing the 150 Attachment Beam in Place

After fixing all the brackets and channels, the 150 beam is fixed in place.

Prop up the 150 beam in position with the double flange on top, the beam will need to be located at a height on the bracket which allows clearance between the gable roof sheets and the gutter. Fix to the end plates of the rafter bracket using two M12 bolts, with the bolt head on the 150 beam side. Insert spacers to prevent the beam from crushing, and bolt in position, using nuts and washers.

Note: Do not over tighten bolts as this can lead to a visible indentation due to the high gloss nature of the material. Refer to figure 8 for fixing spacers.

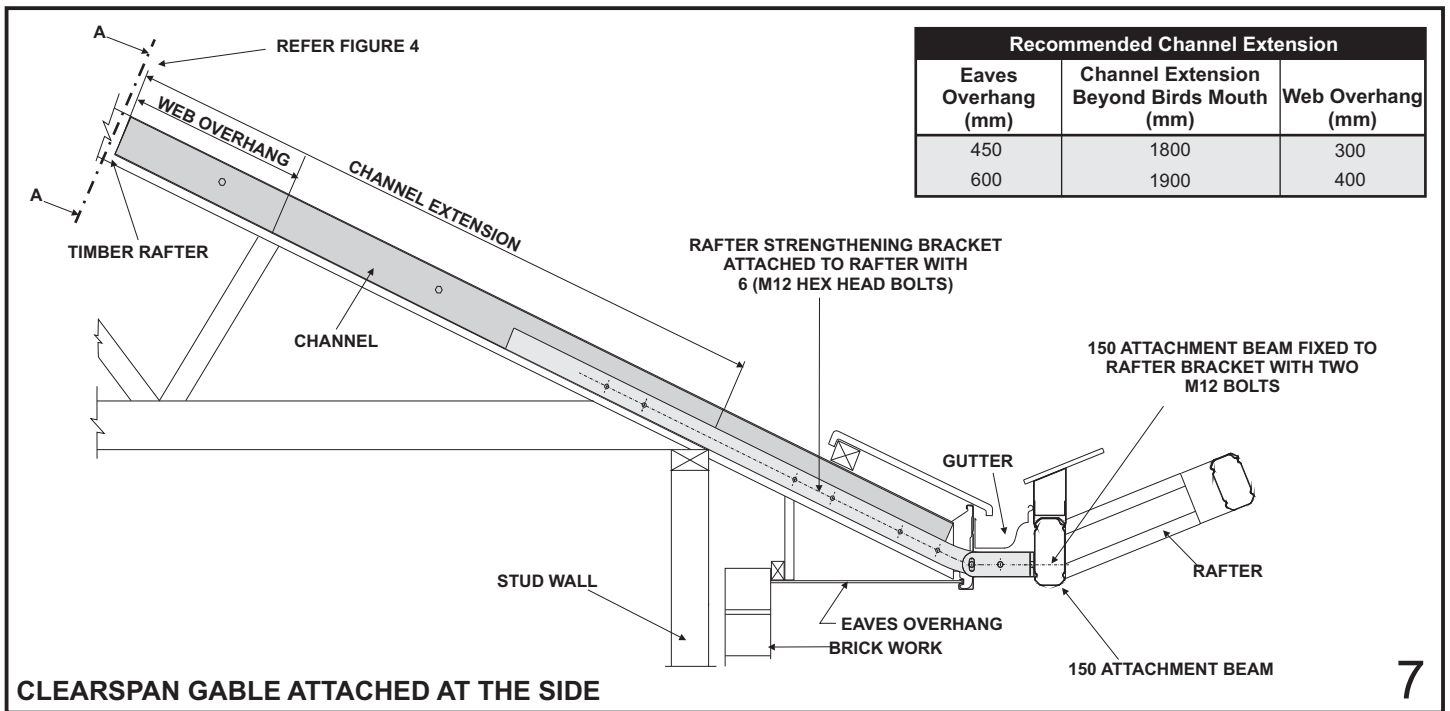

The 150 attachment beam becomes the base for the attachment of the Clearspan gable unit. Figure 7 shows a unit attached at the side.

To insert spacers drill 11 mm holes through the 150 attachment beam. Then drill 16 mm holes on the outside face only, ie this time do not drill all the way through. This will allow the spacer to slide in, from the outside and stop at the other side as shown in figure 8.

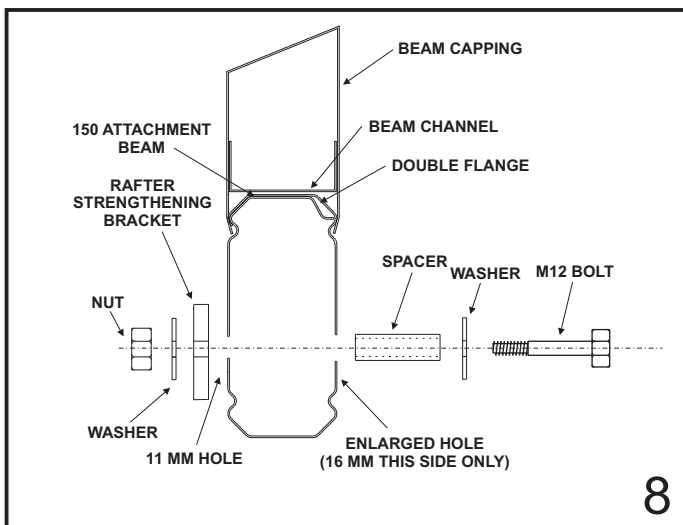

You would have ordered and received your custom made flashings to cover the exposed brackets and holes through fascia. Rivet flashings in place, figure 9 suggests a simplified flashing. You may however use your imagination and design a flashing that suits your individual taste.

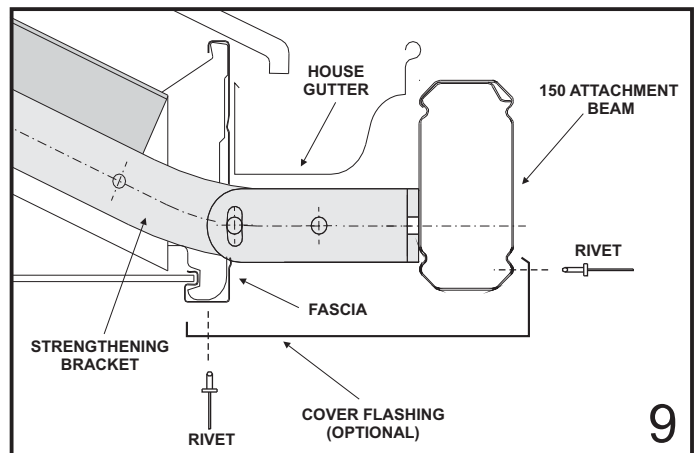

2.2 ATTACHING ON END TO HOUSE

If fixing a Clearspan Gable on its end to a wall, two alternatives are available. Ridge and valley beams are fixed directly to the wall using 150 beam to wall brackets. This option will not require a rear gable frame and back channel is fixed to the wall to accommodate sheets running along the wall. The other alternative requires valley beams be fixed to the wall and a rear gable frame installed. The rear gable frame will need to be slightly offset from the wall to allow the appropriate bracket fixing.

If fixing a Clearspan Gable on its end with suspension brackets to a fascia (Figure 10), typically a soaker flashing is used. In this case the gable rafter at the rear of the unit is to be 153mm from the house fascia in order to accommodate a standard soaker flashing (refer Figures 27 and 28).

Note: If your house gutter is wider than 150mm a custom made soaker flashing will need to be ordered and the rafter set back adjusted to suit.

If fixing a Clearspan Gable on its end to an attachment beam, elevated to the existing house gutter height, the attachment beam is to be as close as possible (within 5mm) to the outside face of the gutter (Figure 29). The 150mm attachment beam is fixed to rafter strengthening brackets as detailed in section 2.1.1.

2.2.1 FASCIA STRENGTHENING

Steel fascia brackets are generally fastened at 1200mm centres to fascia and rafters (Figure 10). It is the builders responsibility to determine the adequacy of the fascia and rafters and the frequency of brackets for each individual situation.

Note: It is the builders responsibility to ensure the existing rafters and fascia are adequately reinforced and strengthened to accommodate any additional attached structure. The reinforcing method must be approved by the appropriate council or engineer.

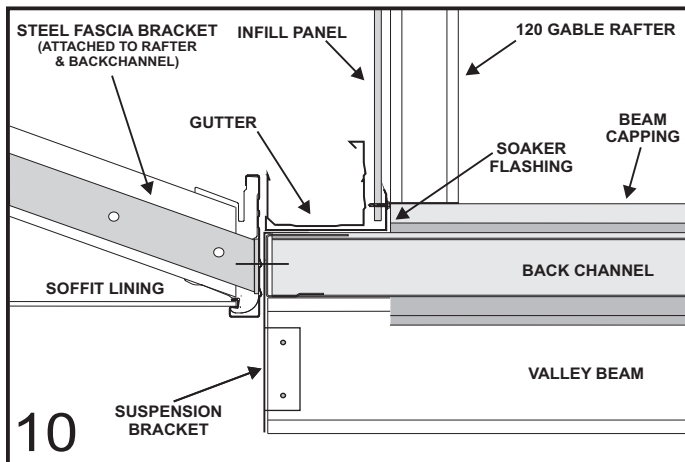

3.0 GABLE FRAME ASSEMBLY

IMPORTANT: Ensure that the double thickness portion is at the top when installing all beams and rafters.

Note: The rafters are supplied pre-cut and drilled at the ridge as shown in figure 11.

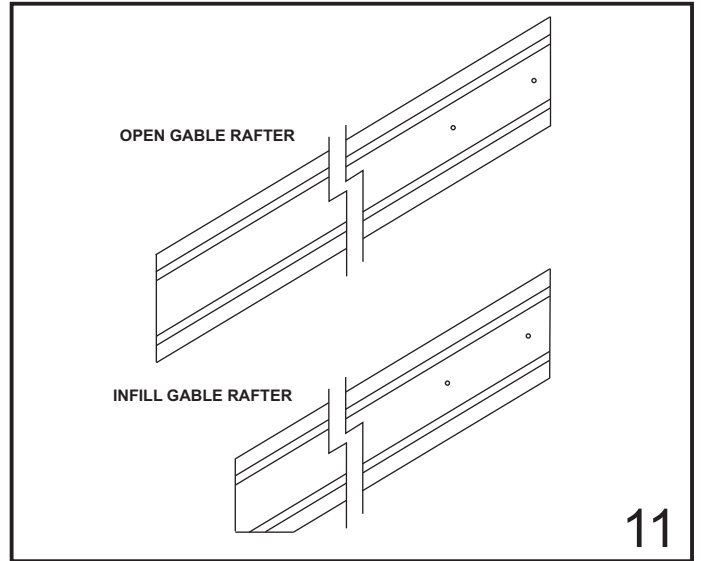

Insert ridge knuckle into the pre-cut rafters and screw together using two 12x20 hex head self drilling screws both sides of each rafter and two 12x20 hex head self drilling screws through the top (double flange side) of each rafter.

Pilot holes indicate screw locations as shown in figure 12. Make sure that the two ends are flush at the connection, leaving no gaps.

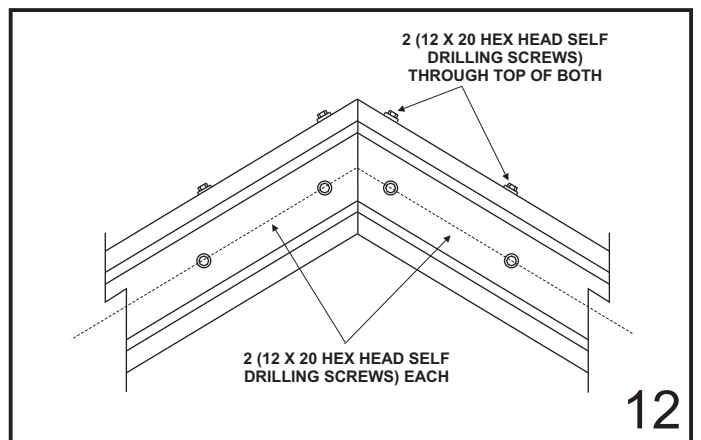

Measure the distance between rafter ends, O, to check valley beam spacing (Figure 13).

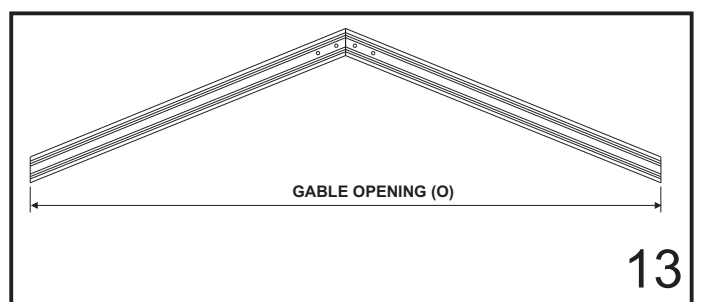

3.1 APEX BRACKET

The Hip Apex bracket is to be fixed to the front face of the front gable frame at the apex. The bracket is to be located so the bottom edge of the apex bracket is in-line with the top edge of the bottom chamfer of the gable frame rafters. The apex bracket is to be located centrally at the apex and fixed through the pre-drilled holes using 12x20 hex head screws (Figure 14).

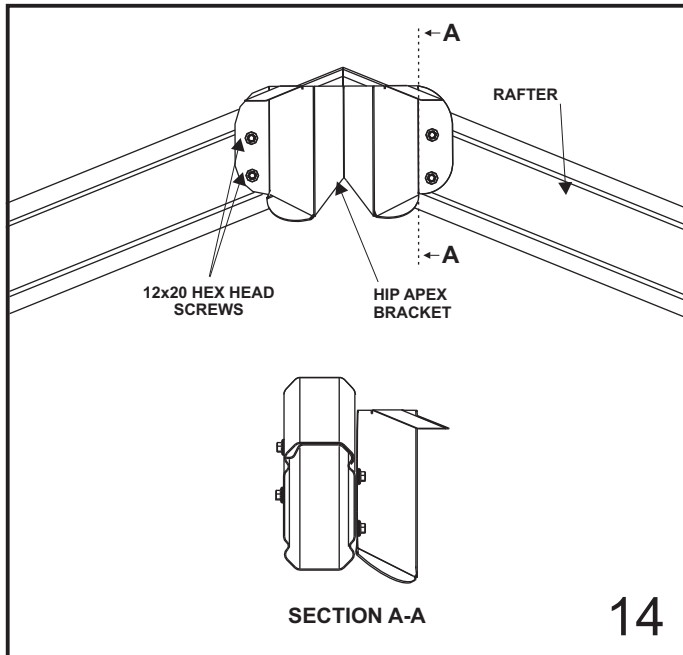

3.2 COLLAR TIES

If collar ties are required on intermediate frames they are to be mitred to suit the pitch of the gable rafters. For gable openings up to 6000mm collar ties are to be located mid-height of the gable frame. For gable openings greater than 6000mm collar ties are to be located at a height to give a collar tie length of 3000mm.

Collar tie brackets are to be fixed back to gable rafters with four 12x20 hex head self drilling screws at the appropriate height. Collar ties are then fixed inside the brackets using three 12x20 hex head self drilling screws either side (Figure 15).

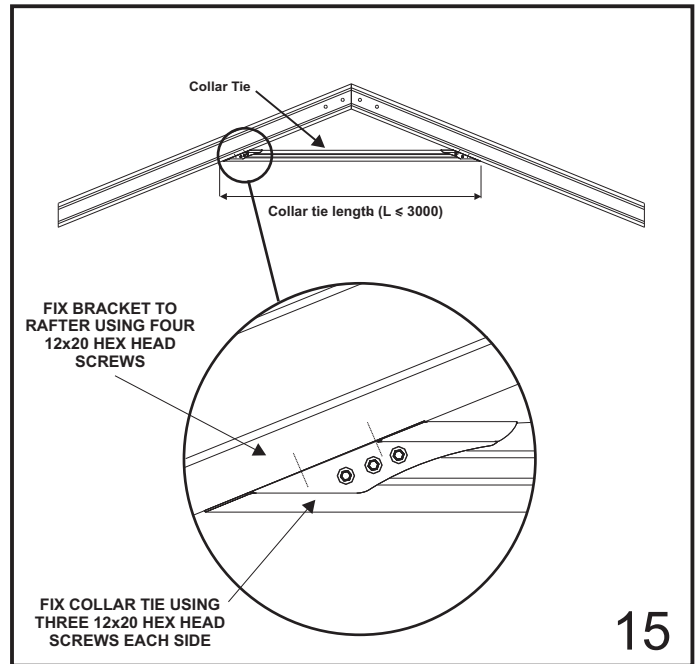

4.0 VALLEY BEAM ASSEMBLY

Before erecting any valley beams fix channel and capping to the top of the beams. Fix beam channel to the top of the valley beam using 12x20 hex head self drilling screws at maximum 500mm centres. Use four screws at the location of all rafters as shown in figure 14. Fix the beam capping to the channel using 3mm rivets or 12x20 hex head screws each side at maximum 500mm centres, ensuring two rivets or screws are used either side at the location of all rafters. The capping break must be located in the top groove (Figure 16).

Beam capping does not need to be mitred and will end to meet at a point with the hip fascia beam on the inside corner of the hip end. Beam capping is also fixed to the hip fascia beam. Refer figures 21 and 22 for beam capping locations.

If attaching the valley beam to a header beam, notch the capping so that it sits on top of the beam as shown in figure 26.

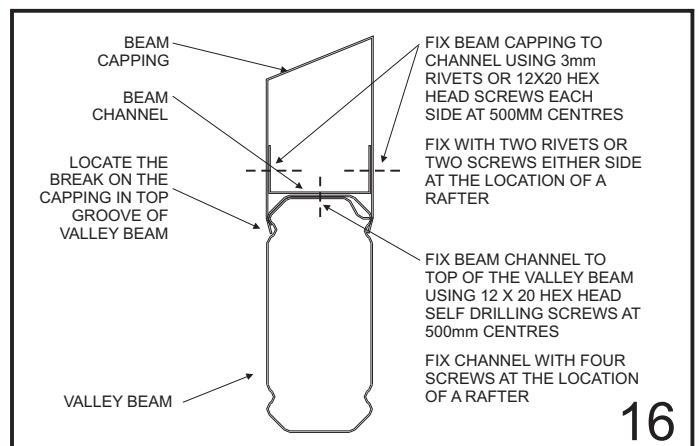

4.1 SIDE ATTACHED

For side attached units fix the rafter to valley brackets to the beam capping (150 attachment beam will be considered a valley beam) at the correct rafter positions (refer Section 6) using six 12x20mm hex head screws per bracket through the pre-drilled holes (Figure 18). Please note that the bottom face of the bracket is inline with the bottom edge of the upper groove in the beam. Check positions before drilling.

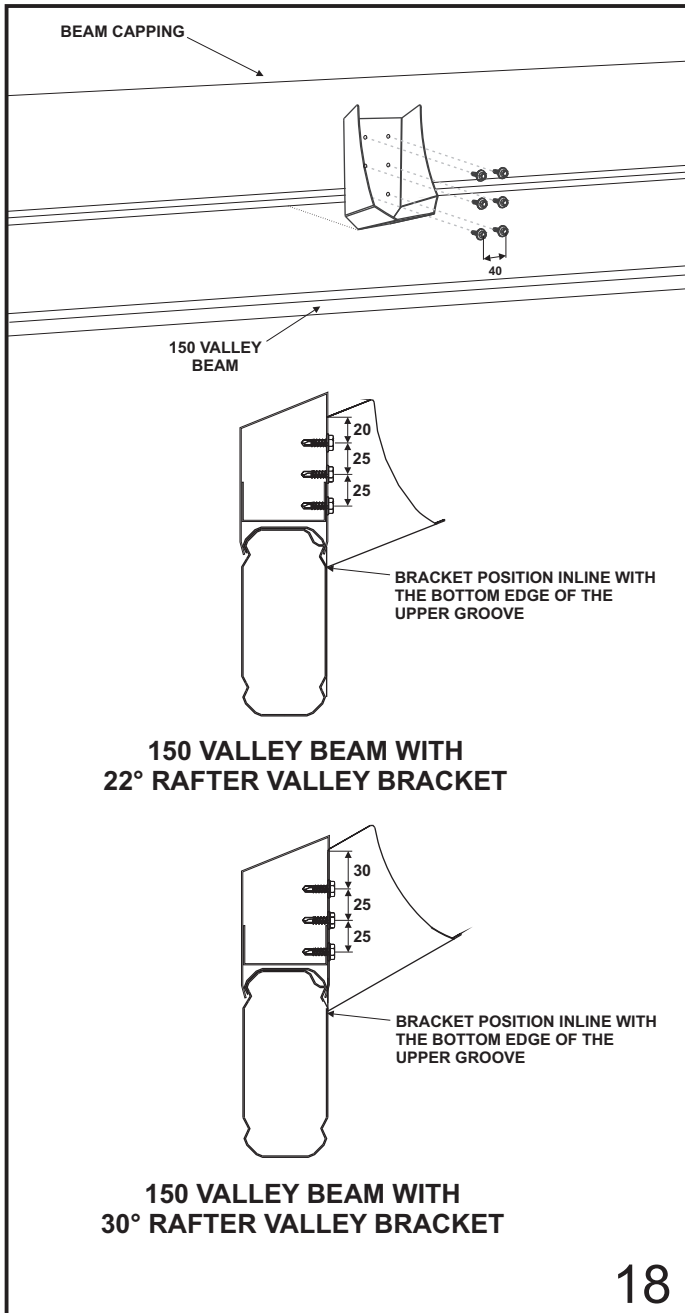

If any intermediate columns are required measure the valley beam marking where they meet. Fasten post brackets as explained in the 'Outback Flat Attached Verandahs, Patios & Carports' under "FRONT FASCIA BEAM". Support the second valley beam at the spacing determined in part 3.0 on adjustable construction props.

4.2 END ATTACHED

For units attached on the end to a wall, wall brackets are

positioned at either side of the gable opening at the spacing determined in part 3.0. The first bracket is fastened to the wall with two M8x65mm masonry anchors. The curved legs of the bracket are located at the top (Figure 19).

Locate the first valley beam (beam cap on top) up into the wall bracket so the curved legs locate against the top flute of the beam. The valley beam is fastened to the wall bracket with 12x20 hex head screws in the pre-drilled holes while the opposite end is supported on adjustable construction props.

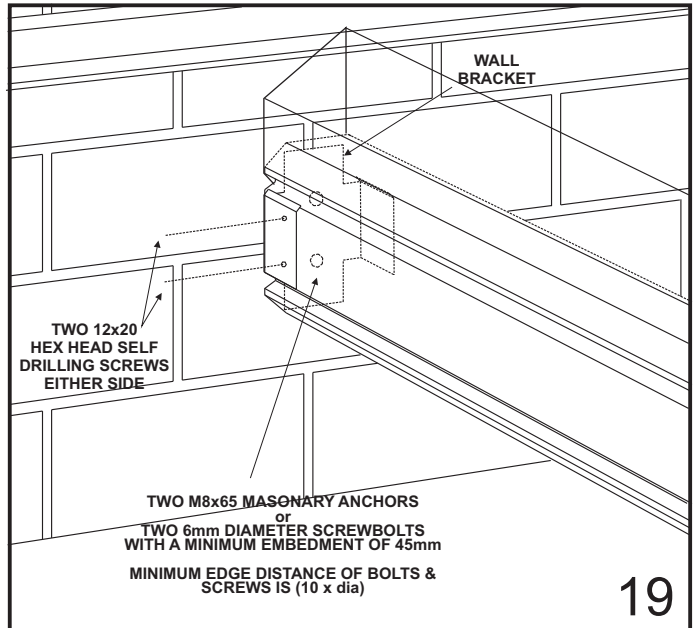

For units attached on the end to a fascia, suspension brackets are positioned at either side of the gable opening at the spacing determined in part 3.0. The top tab of the suspension bracket must be located between the fascia and back channel. A minimum of two 12x20 hex head screws are fixed through back channel, suspension bracket and steel fascia while two 12x25 type 17 screws are used to fix through back channel, suspension bracket and timber (Figure 20).

Note: If back channel is not present, (ie, no adjacent flat roof) locate washer plate behind steel fascia at suspension bracket. Fix through bracket, fascia and plate.

The first valley beam is fastened into the suspension bracket with 12x20 hex head screws through the dimples while the opposite end is supported on adjustable construction props.

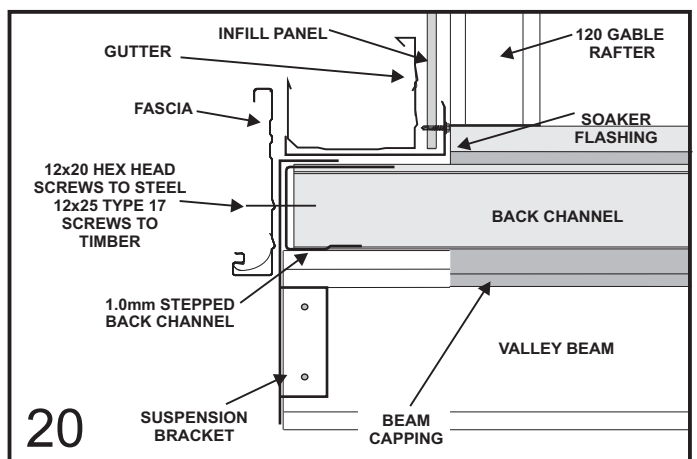

For units attached on the end to an attachment beam (Figure 32), beam to beam brackets are positioned at either side of the gable opening at the spacing determined in part 3.0.

Fix beam to beam brackets to the attachment beam (header beam) with two 12x20 hex head screws so they clamp the beam filler to the beam (Figure 20).

The first valley beam is fastened over the beam to beam bracket with two 12x20 hex head screws either side while the opposite end is supported on adjustable construction props.

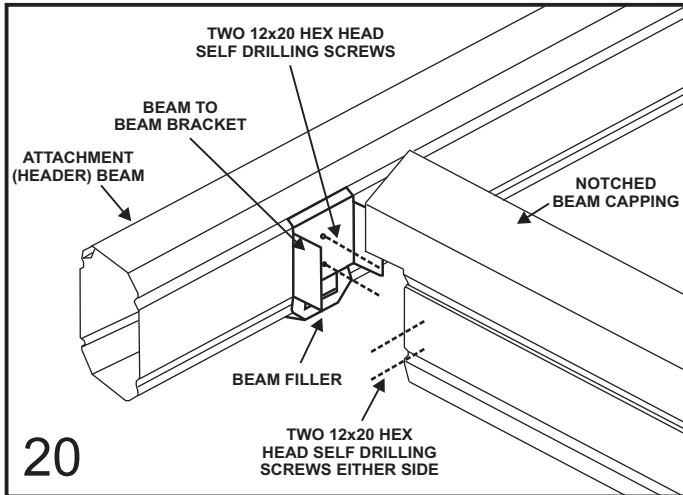

If any intermediate columns are required measure the valley beam marking where they meet. Fasten post brackets as explained in the installation guide : 'Outback Flat Attached Verandahs, Patios & Carports' under "FRONT FASCIA BEAM". This can be done before valley beams are fixed in place.

Support the second valley beam on adjustable construction props but do not fix to the wall, fascia or attachment beam until the front gable frame has been attached.

Fix the rafter to valley brackets to the beam capping at the correct rafter positions (refer section 6). Fixing details as shown in section 4.1.

5.0 HIP FASCIA BEAM

Either the hip fascia beam is connected to the valley beam or visa vera depending on the overall unit design (refer Figure 21). Post brackets are to be fastened to the appropriate beam so posts can be located directly in the corner of the Hip End. Refer to 'Outback Flat Attached Verandahs, Patios & Carports' for post bracket fixing details.

Attach the beam to beam bracket to the beam which is being attached to using two 12x20 hex head screws. Slide the other beam into the beam to beam bracket and fix using two 12x20 hex head screws either side of the beam. Support the first hip corner on an adjustable construction prop.

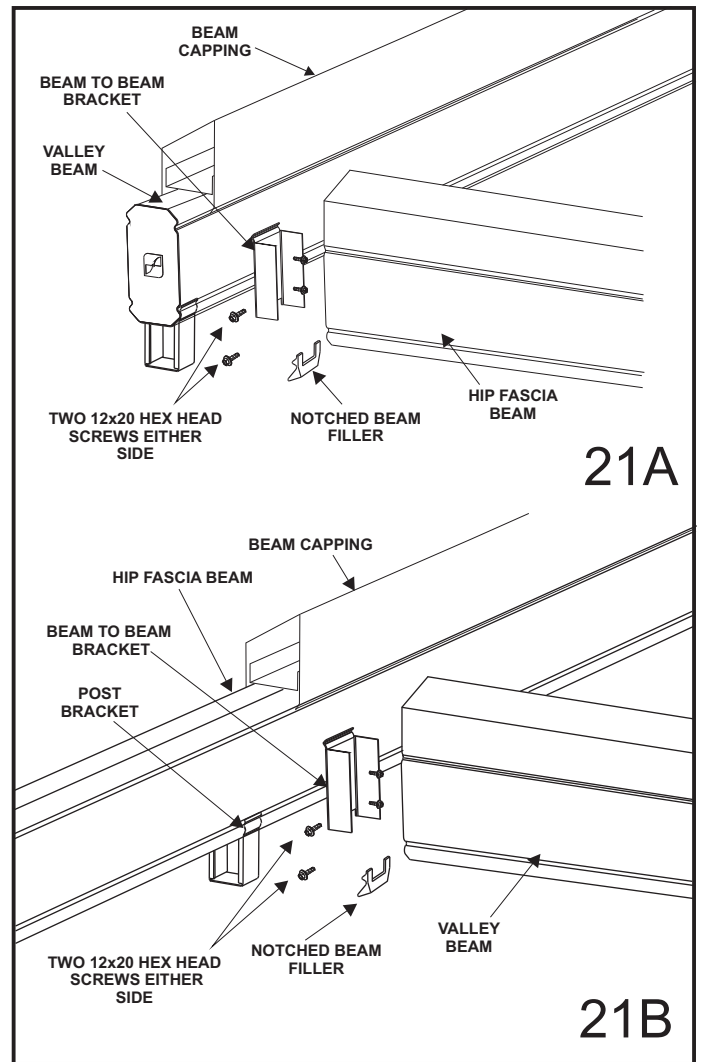

Hip beam capping mitres are used to cover the gap made by the beam capping. Rivet the mitre through both overlaps to the beam channel and to the top of the beam capping (Figure 22).

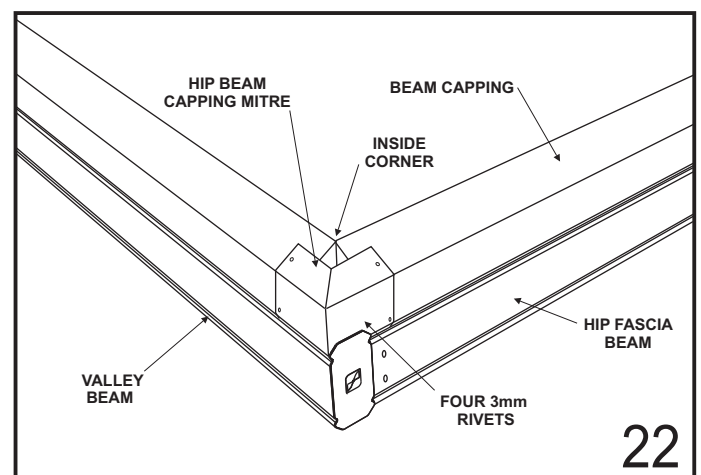

6.0 GABLE FRAME CONNECTION

Note: Be aware that gable frames are always 120 beams and valley beams are always 150 beams for Clearspan units with a hip end.

6.1 GABLE FRAMES (Figure 1)

The front gable frame will need to be set back from the front of the valley beams to accommodate the hip end. Refer to Figure 23 and Table 1 for set back distance.

The rafter to valley brackets will have been attached to the beam capping using six 12x20 hex head screws (Figure 17, Section 4.1) at the location determined from Table 1 (Figure 23).

| OPENING, O | A (Set Back) |
|------------|--------------|
| 1200 | 600 |
| 1500 | 750 |
| 1800 | 900 |
| 2100 | 1050 |
| 2400 | 1200 |
| 2700 | 1350 |
| 3000 | 1500 |
| 3300 | 1650 |
| 3600 | 1800 |
| 3900 | 1950 |
| 4200 | 2100 |
| 4500 | 2250 |
| 4800 | 2400 |
| 5100 | 2550 |
| 5400 | 2700 |
| 5700 | 2850 |
| 6000 | 3000 |
| 6300 | 3150 |
| 6600 | 3300 |

Table 1
Interpolation may be used to determine values between those shown.
All lengths in millimetres (mm).

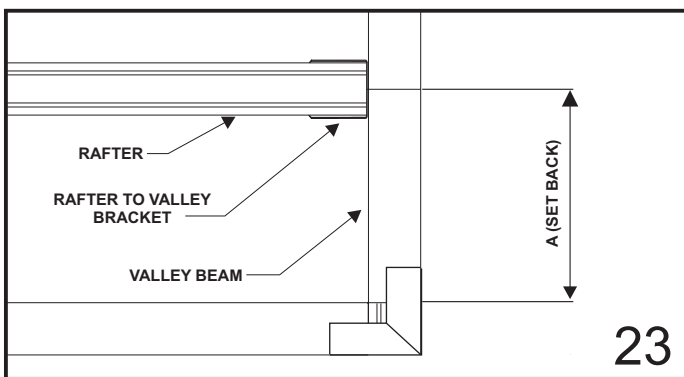

Fix the gable rafters to the rafter to valley brackets with two 12x20 hex head screws either side (Figure 24).

If attached on the end, attach the second valley beam into the wall or suspension bracket.

Note: If the unit includes rear infill a rear header beam is required and must be installed before fixing the second valley beam in position, refer section 6.2.

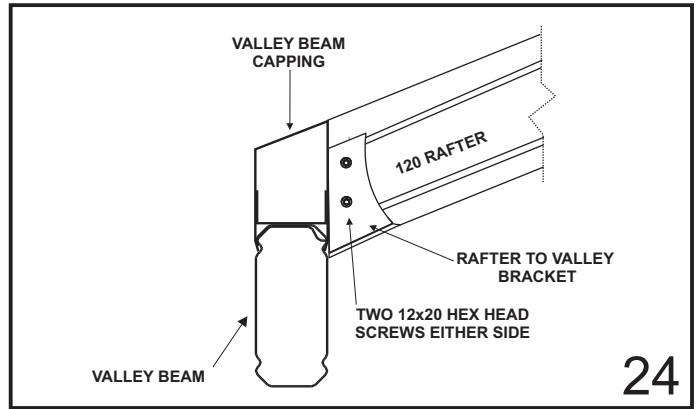

Intermediate frames should be spaced evenly and fixed into rafter to valley brackets as previously described.

A rear gable frame without a header beam is fixed as per an intermediate frame.

6.2 REAR INFILL

A rear header beam will be required if the unit includes infill to the rear gable frame. For units attached at the rear with suspension brackets, the rear header is fixed between valley beams using beam to beam brackets. If fixed at the rear to an attachment beam (Figure 29), the attachment beam becomes the header (valley beams are fixed to the header beam) and if attached on the side the rear header is fixed to the attachment beam with beam to beam brackets.

Attach gable beam brackets to the rear header beam against the beam capping at spacing, O, as determined in section 3. A minimum of four 12x20 hex head screws are required to fix the bracket to the beam capping and a minimum of four screws to fix to the header beam (Figures 25 or 26).

The rear gable frame rafters are supplied notched at the base to fit the gable beam brackets. Rafters are fastened inside the gable beam brackets with a minimum of three 12x20 hex head self drilling screws either side as shown in figures 25 or 26.

Refer section 15 for details of fixing infill panels to gable frames.

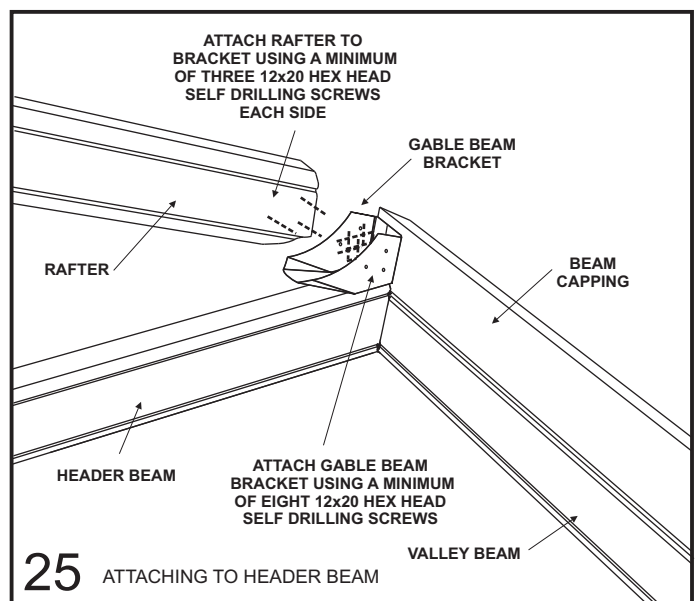

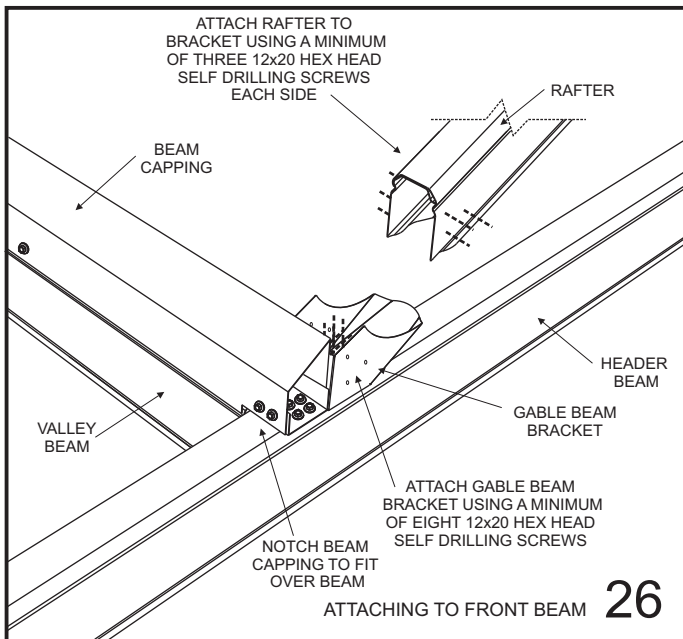

6.2.1 SOAKER FLASHING

In the case of a rear infill panel, a soaker flashing is used to conceal the existing house gutter, waterproof the rear end of the gable and neatly finish the base of the Infill panel (Figure 27).

The rear gable frame and header beam are positioned 153 mm from the house fascia in order to accommodate the standard soaker flashing which is optional with the Outback® unit (Figure 28). The frame is fixed on the rear header beam into gable beam brackets as detailed above.

Fix the standard soaker flashing into position on top of the back channel and underneath the gutter. Infill panels must be fixed with split tail soft pull rivets at 500mm centres a minimum of 20 mm above the pan of the soaker flashing. This will reduce the possibility of moisture being absorbed into the sheet.

Refer section 15 for details of fixing infill panels to gable frames.

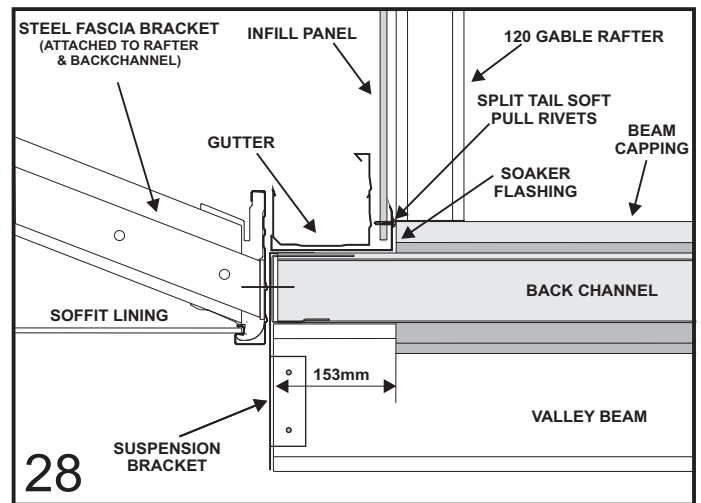
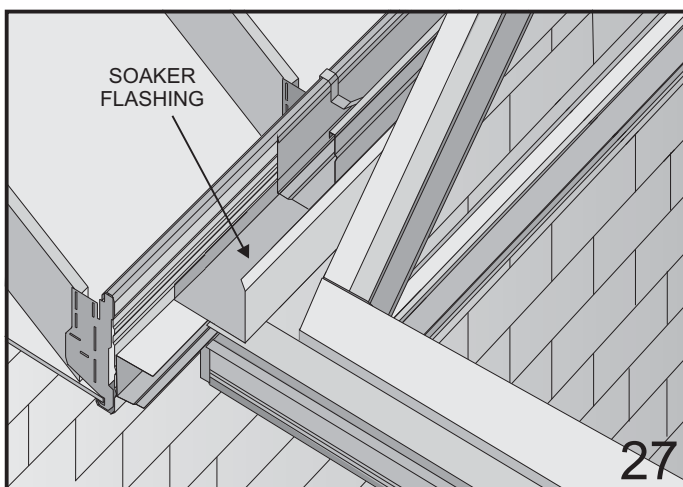

Note:

1. If your house gutter is wider than 150 mm a custom made soaker flashing will need to be ordered to the required dimensions. The rafter setback will need to be adjusted to suit.
2. Do not form stop ends at either end of the soaker flashing.
3. Soaker flashing is not to come in contact with the base of the house gutter.

6.2.2 HEADER FLASHING

When a gable is fixed at the rear to an attachment beam, elevated to the existing house gutter height, typically a header flashing is used in conjunction with the rear infill. In this case, the rear attachment beam is considered a header, and along with the rear gable frame is fixed as close as possible (within 5mm) to the existing gutter in order to accommodate the header flashing. The gable frame is fixed on the rear header to gable beam brackets as previously described.

Fix the header flashing into position over the existing gutter lip with rivets. Infill panels are located behind the header flashing and fixed with split tail soft pull rivets at 500mm centres (Figure 29).

Refer section 15 for details of fixing infill panels to gable frames.

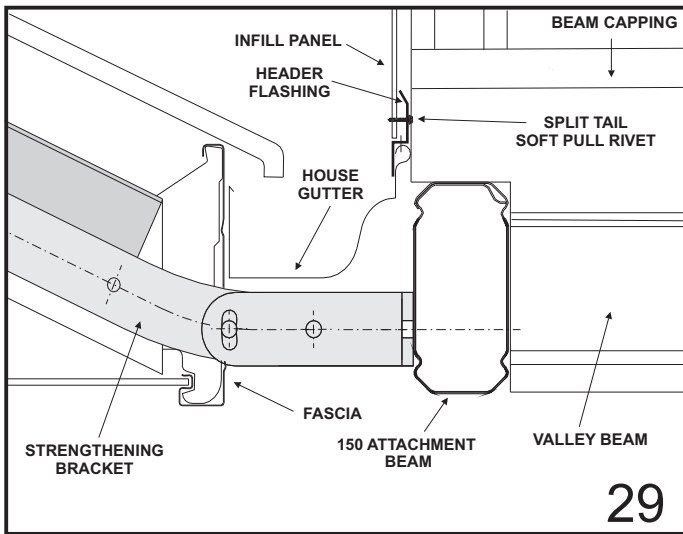

29

7.0 PERIMETER BRACKETS

Perimeter brackets are to be located at the internal join of the beam capping so the bottom face of the bracket is in line with the bottom edge of the upper groove in the beam capping (Figure 30). Brackets are to be fastened to the beam capping using four 12x20 hex head screws through the pre-drilled holes. Note: Ensure the bottom screws fix through internal beam capping channel.

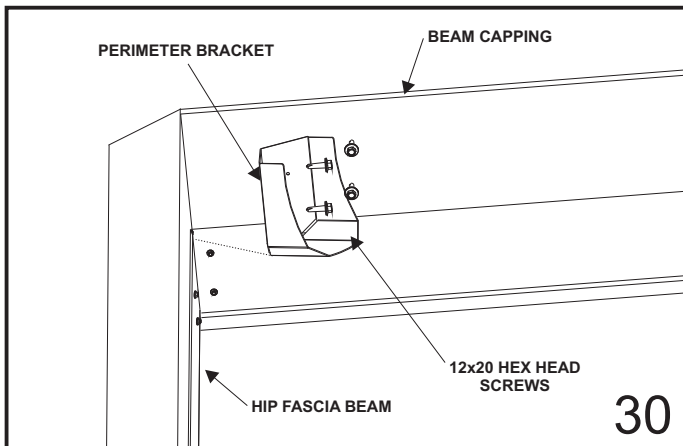

30

8.0 HIP RAFTERS

Having all the Perimeter Brackets in place will allow rafters to be located. It is important that rafters are firstly fixed at the apex, position rafters over the apex bracket tabs so the cut face of the rafter is flush with the face of the bracket.

Two 12x20 hex head screws are used to fix the rafter to the tab with the first screw being located 20mm from the front face of the bracket and the second 20mm from the first screw (Figure 31).

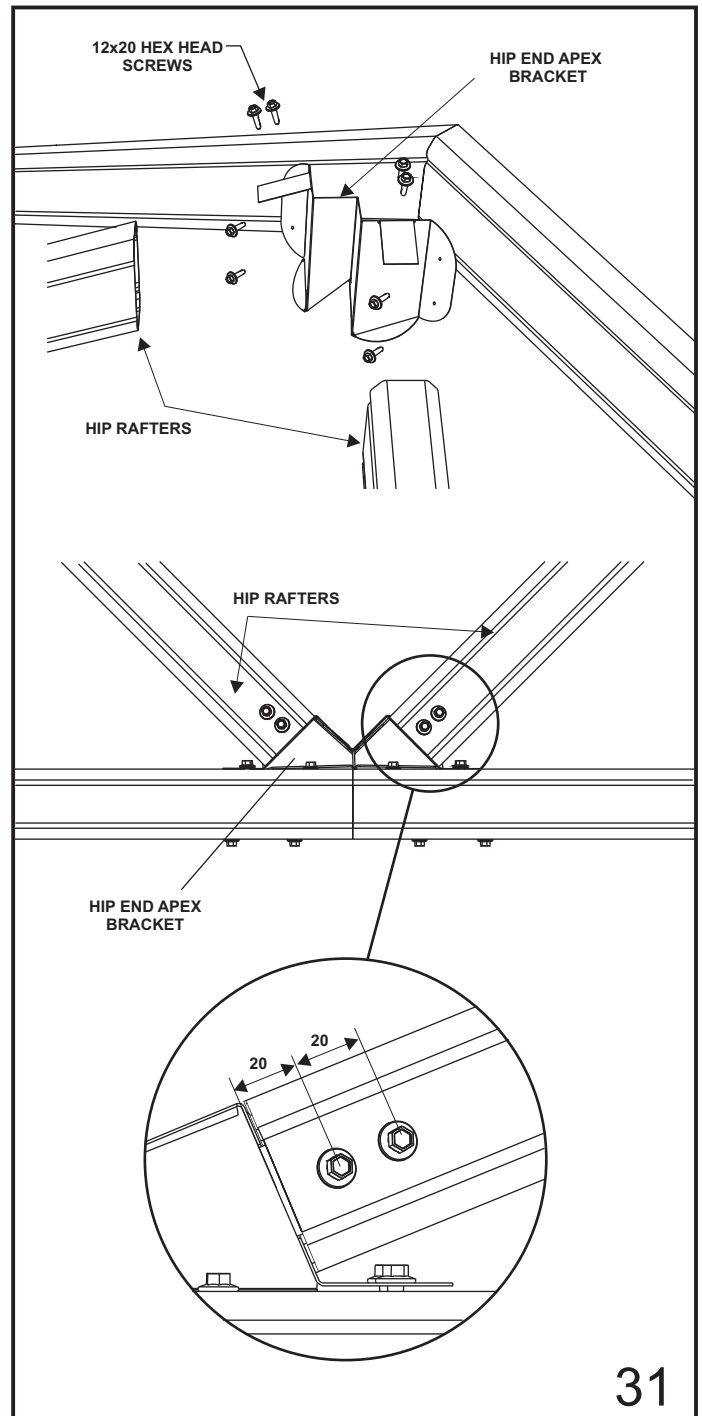

31

With all hip rafters fixed at the apex they can be fastened to the perimeter brackets. Fix rafters through the base of the perimeter brackets using two 12x20 hex head screws at a minimum spacing of 30mm. As a small tolerance is allowed for at this bracket it is important that the screws are located at least 20mm from the bracket edge and the bottom edge of the rafter (Figure 32).

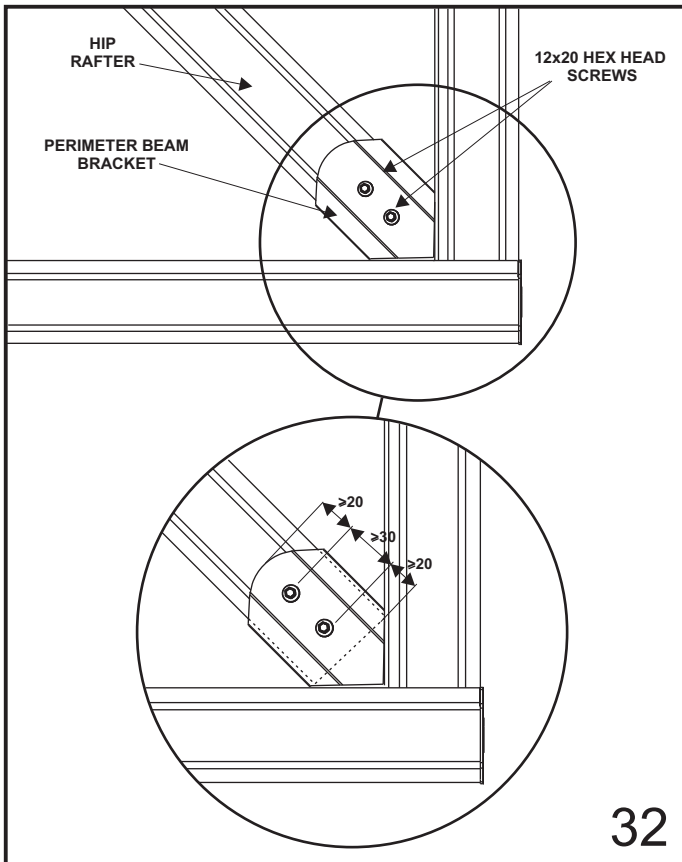

32

9.0 CLEARSPAN TWO PIECE BACK CHANNEL ASSEMBLY.

A special two piece back channel will be required and is to be located along the hip rafters before the decking is fastened in place. The flashings are screwed to the centre of the hip rafter using 12x20 hex head screws at 500mm centres (Figure 33). The back channel shall run the full length of the hip rafters and should be mitred at the apex for a neat finish. BIP foam is inserted either side of the back channel before decking is fixed in place.

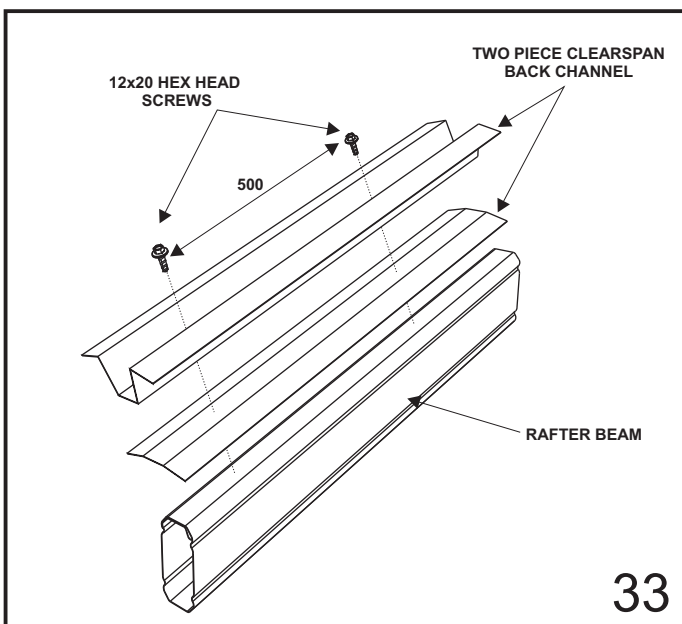

33

10.0 ASSEMBLING RIDGE BEAM

Assemble ridge beam before attaching to gable frames. Fix angled back channel to both sides of the ridge beam using 12 x 20 hex head self drilling screws at 500mm centres, ensuring that the top of the back channel is in line with the bottom of the beam chamfer as shown in figure 34. The back channel should run 68mm past the end of the beam at both ends of the ridge beam. If there is no rear portal frame, finish the back channel flush at one end.

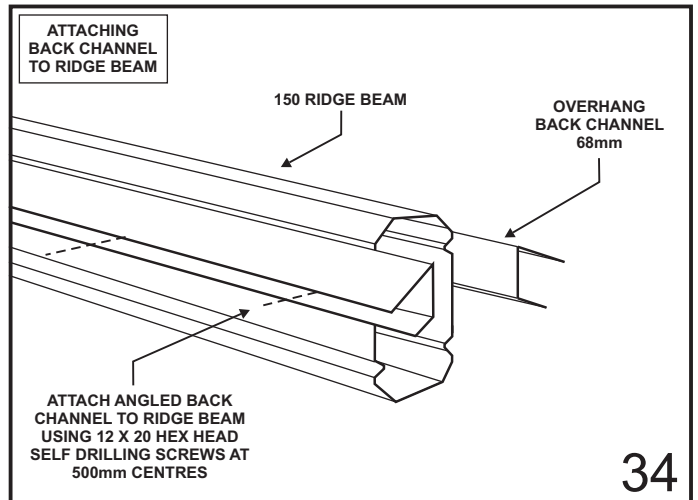

34

In the case of decking overhanging the gable frame (non-hip end), run the angled back channel to the end of the overhanging ridge beam as shown in figure 35. A modified suspension bracket will be required on both sides of the ridge to support overhang.

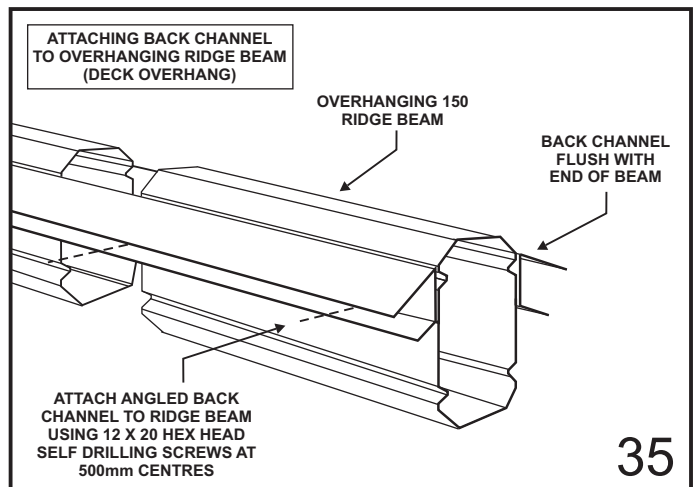

35

10.1 ATTACHING RIDGE BEAM

Fix modified suspension bracket at the ridge using four 12 x 20 hex head self drilling screws through the gable frame and into the ridge knuckle.

Position the ridge beam so that the angled back channel rests on the gable frame (Figure 36). Fix to modified suspension bracket using two 12x20 hex head self drilling screws each side.

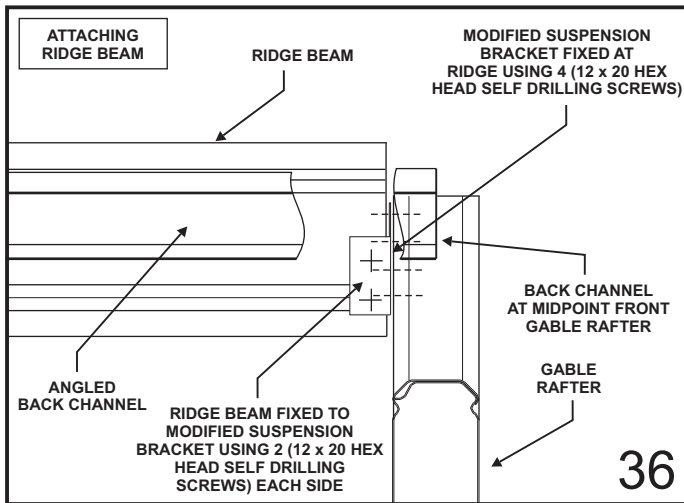

11.0 REMAINING FRAME ASSEMBLY

Assemble the remaining framework of the verandah as per the installation guide 'Outback Flat Attached Verandahs, Patios & Carports'.

Fix the posts, as described in the instruction brochure under "COLUMNS AND FOOTINGS" or "ALTERNATIVE FOOTING".

Note: All adjustable construction props are to be left in position until decking is attached and concrete is set.

12.0 GUTTERING

Connect the gutter to the flat roof Outbacks® as described in 'Outback Flat Attached Verandahs, Patios & Carports'. Flat roof gutters need to end flush with the gable valley beams and stop ends are fixed.

Gutter around the hip end needs to be mitred if continuing around the corner. Cut 30mm tabs in the gutter back lip at 1000mm intervals and fold back. Fix the gutter to the beam capping, through the tabs with rivets as shown in figure 37. Once decking is attached (Section 13.0) fit gutter straps at a maximum 1000mm intervals, attaching them to the top of the decking with rivets. Waterproof rivets with silicone. The same method is used where there is no flat roof adjacent the hip.

The hip end gutter will be at a higher level than the flat roof gutter. The lower gutter is notched if required at the point the hip gutter intersects to allow the hip end gutter to overlap and flow directly into the lower gutter (Figure 38).

Alternatively, the flat roof gutter and the hip end gutter may be kept mutually exclusive having gutter stop ends sealing the gutters to keep them separate. Separate downpipes will then be necessary.

All gutter joins are to be waterproofed with silicon.

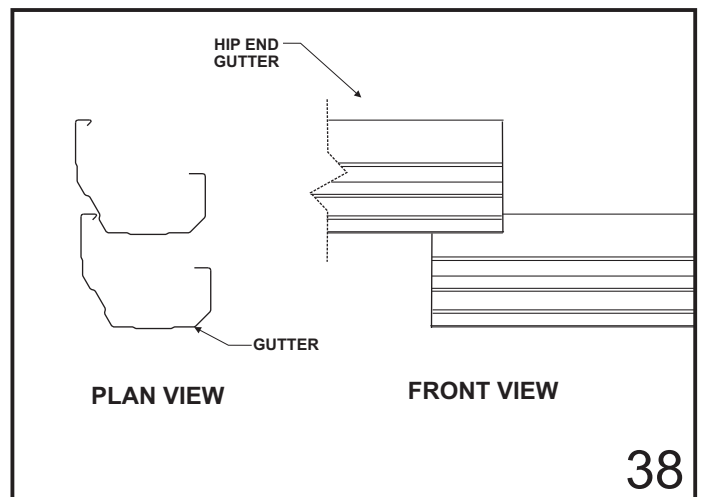
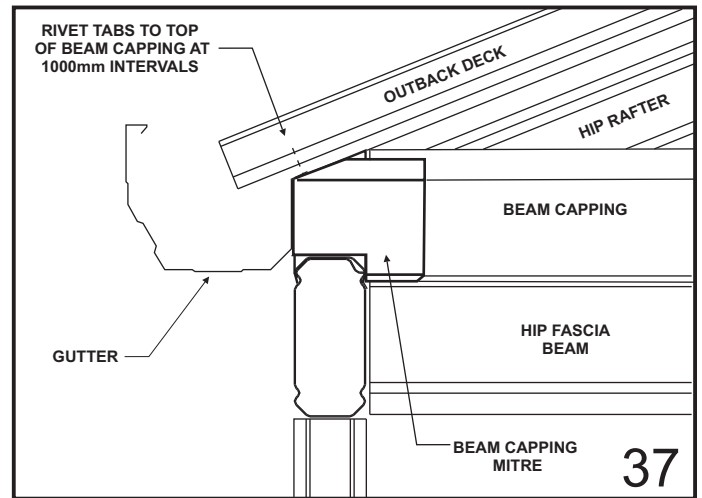

13.0 ATTACH DECKING

13.1 FLAT ROOF

Attach the decking to the flat roof verandah first as laid out under "THE DECKING" ('Outback Flat Attached Verandahs, Patios & Carports'), starting from the valley beam and working away, on both sides.

The back channel should have been attached upside down (the shorter leg on top) along beam capping to assist the fixing of decking. (Figure 39).

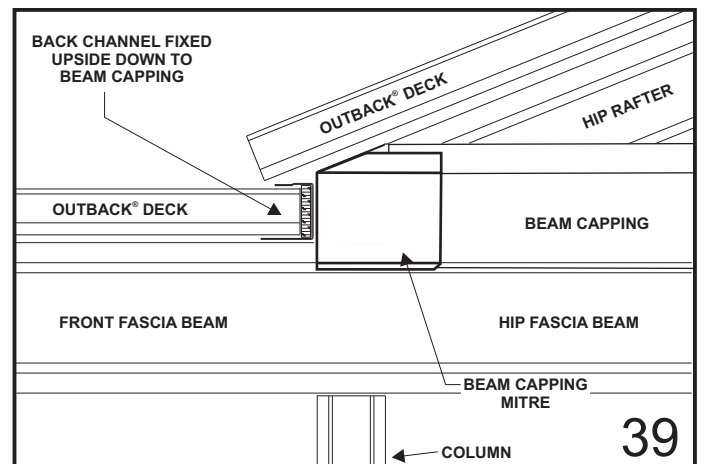

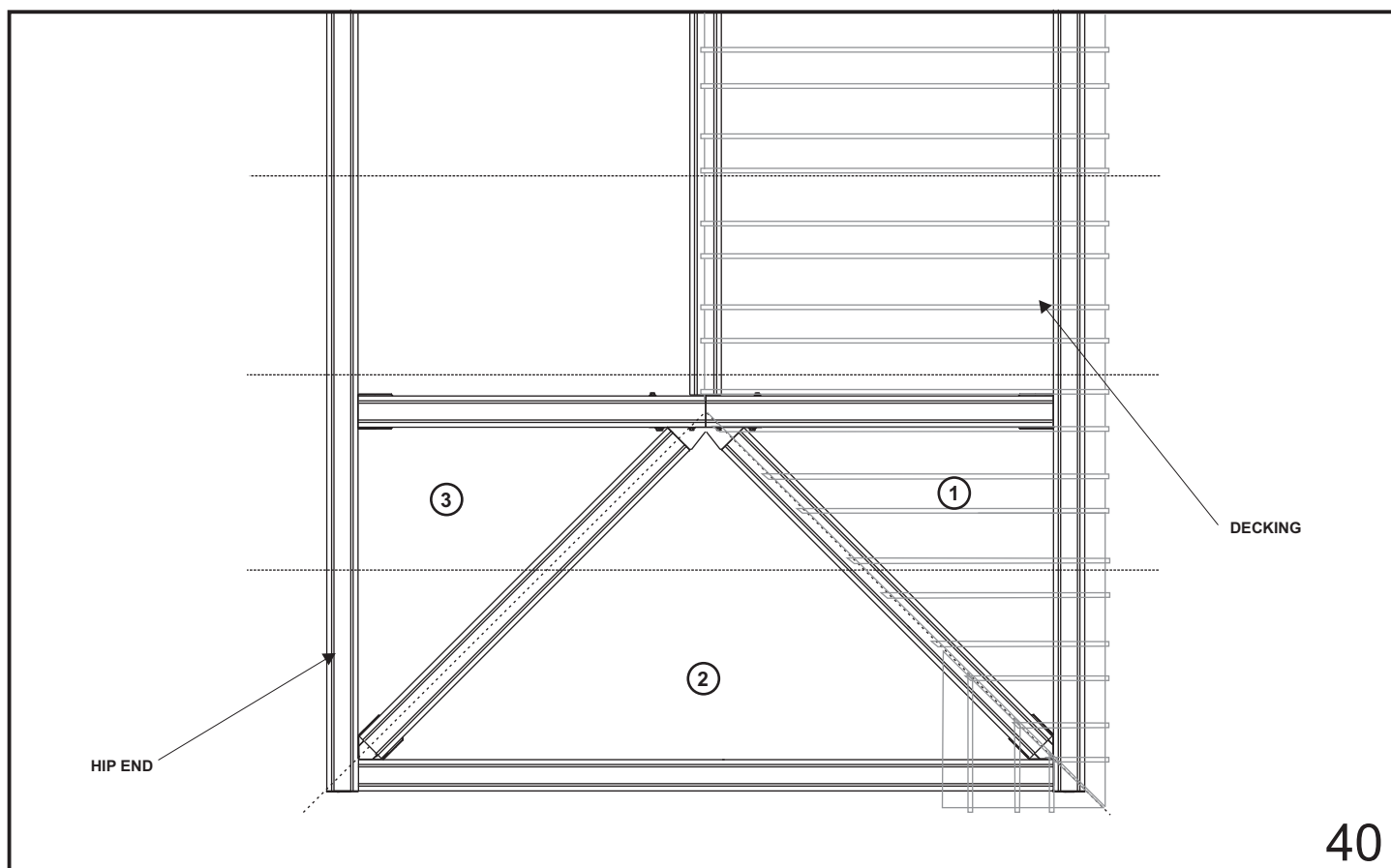

13.2 CLEARSPAN GABLE

When attaching the decking to the gable, start from the rear (non hip end) on one side of the gable. Fix the deck to the angled backchannel at the ridge, and to the capping at the valley beam.

If the deck of the flat roof section runs perpendicular to the valley beams, align the ribs of the gable decking up with the flat roof section.

Note: If Installing Outback Rooflite, refer to "OUTBACK ROOFLITE INSTALLATION" ('Outback Flat Attached Verandahs, Patios & Carports').

13.3 HIP END

At the point when less than one full sheet is required to pass the centreline of the end gable frame on one side, the Outback® decking will need to be cut to suit. Continue laying deck past the end gable frame (section 1, Figure 40) and cut the sheeting to fit inside the Clearspan two piece back channel. Cut sheeting to fit sections 2 and 3 and continue back down the side of the Clearspan Gable.

Outback® deck is riveted to the base flashing at 250mm centres (Figure 41).

Note: Sheets are to be taken down from the framework to be cut. It is recommended sheeting is supported in a horizontal plane off the ground at a comfortable height for cutting.

All sheeting which ends at the apex is to be cut to a point so it meets directly above the centre of the end gable frame.

The Outback® decking will need to overhang the beam capping allowing water to flow directly into the gutter (Figure 37).

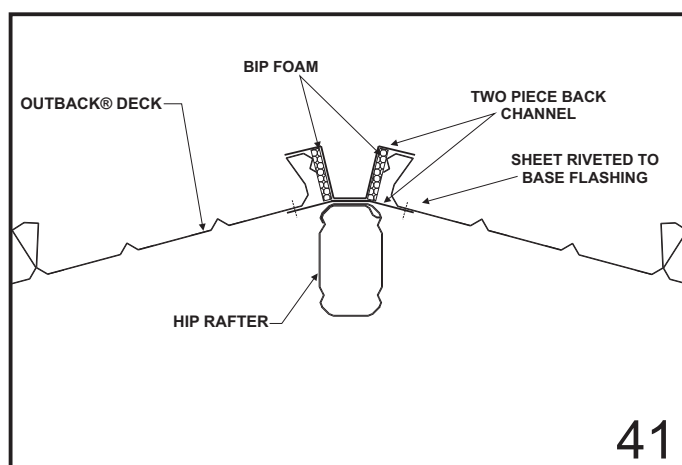

14.0 RIDGE CAPPING

14.1 MAIN RIDGE

Position the ridge cap over the ridge beam and two angled back channels and rivet into the channel (Figure 42).

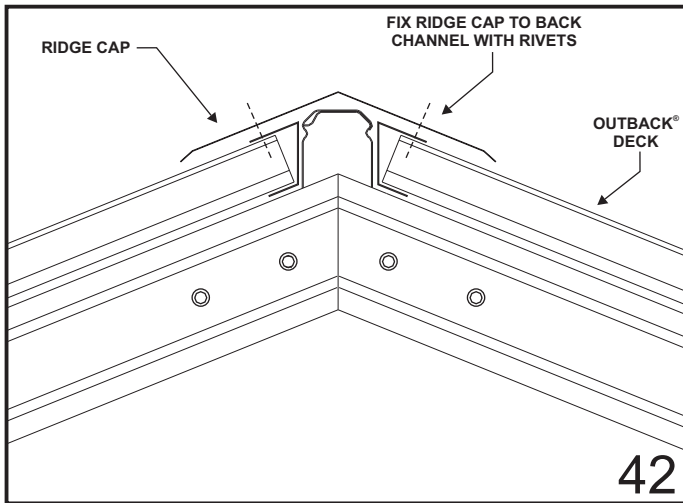

14.2 HIP END CAPPING

Ridge cap is also used over all hip end rafters to conceal the two piece backchannel. The ridge cap is positioned over the channels and screwed in place through the channels (Figure 43). Ridge capping will need to be cut to meet a point at the apex as detailed in figure 44. Allow an approximate 20mm overlap at the ridge. The capping is to be fully silicon sealed at the apex for waterproofing.

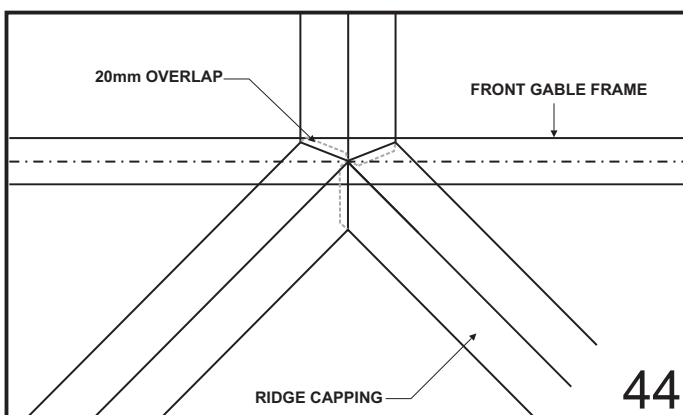
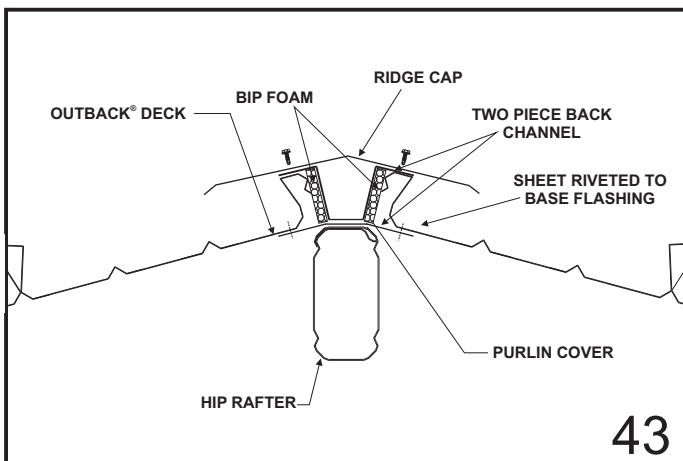

15.0 INFILL PANELS

Two styles of header flashings are available to neatly finish the base of infill panels, one is used on header beams with gutter and the other for headers without gutter. Gable infill panels are to be cut in triangular shapes to fit the end frame.

Panels can be painted to the desired colour before installing.

End struts are fixed mid-span of the header to a header beam bracket at the base and an end strut plate at the ridge (Figure 45).

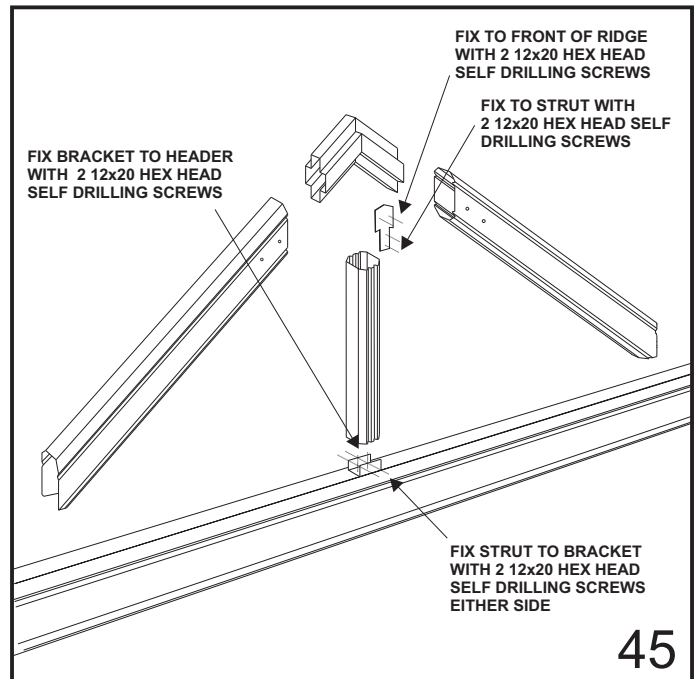

15.1 HEADER BEAM WITH GUTTER

Attach the header flashing to the rear gutter lip with rivets. Infill panels are fixed through the top groove of rafters and the end strut with 8x35mm self embedding teks at 500mm centres in non-cyclonic areas and 250mm centres in cyclonic areas. Panels are fixed at the base through the header flashing with split tail soft pull rivets at 500mm centres (Figure 46).

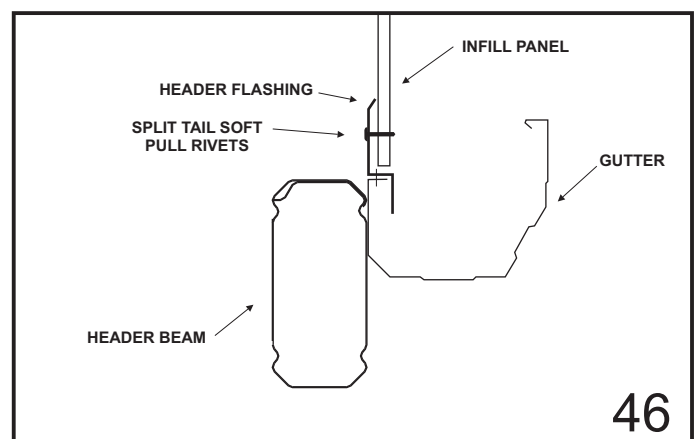

15.2 HEADER BEAM WITHOUT GUTTER

Infill panels are fixed through the top groove of rafters and the lower groove of the header beam with 8x35mm self embedding teks. Fix at 500mm centres in non-cyclonic areas and 250mm centres in cyclonic areas. Panels are fixed to the end strut at the same spacings. Attach the header flashing to the underside of the header beam with 12x20 hex head screws to neatly finish the base of the infill panels (Figure 47).

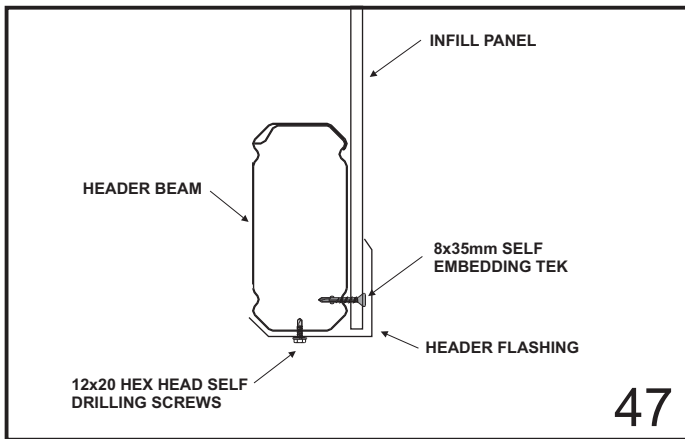

16.0 ATTACHING BARGE CAPPING

If barge capping is required at the opposite end to the hip, attach the barge cap by screwing the lower lip to the rafter and rivet the top section to the deck, as shown in Figure 48. Mitre the barge at the apex of the gable for a neat finish. Run the barge cap along the gable section to where it meets the flat verandah deck and finish neatly.

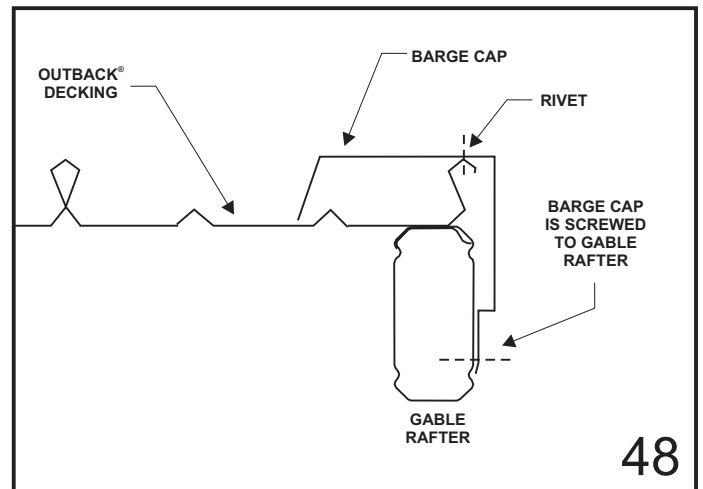

17.0 HELPFUL TIPS

Leave plastic coating on members until they are about to be fastened to the structure. This will help prevent scratching of the colour finish.

Sweep the roof and clean gutters after the completion of work. Ensure any swarf and rivet stubs are removed as they can cause unsightly rust stains.

Do not allow soil to remain in permanent contact with the columns, as corrosion will result in the base of the column. Refer to the "Selection, Use and Maintenance of Stratco Steel Products" brochure for complete details of the maintenance requirements.

Double check all measurements and drilling locations before proceeding.

Regularly check framework for squareness and vertical alignment to make sure it hasn't moved during construction.