

# MULTISPAN GABLE WITH HIP END ATTACHED PATIO

## STRATCO OUTBACK® ASSEMBLY INSTRUCTIONS.

### Your supplementary guide to building an ATTACHED MULTISPAN GABLE VERANDAH or PATIO WITH HIP END



This set of instructions should be used in conjunction with the Stratco instruction brochure 'Flat Verandahs Attached - Your complete guide to building an Attached Outback® Verandah, Patio or Carport'.

#### BEFORE YOU START

Carefully read these instructions, along with the Stratco Flat Verandahs Attached Instructions. If you do not have all the necessary tools or information, contact Stratco for advice. Before starting lay out all components and check them against the delivery docket. The parts description identifies additional gable parts, and the component layout diagram indicates their fastening position.

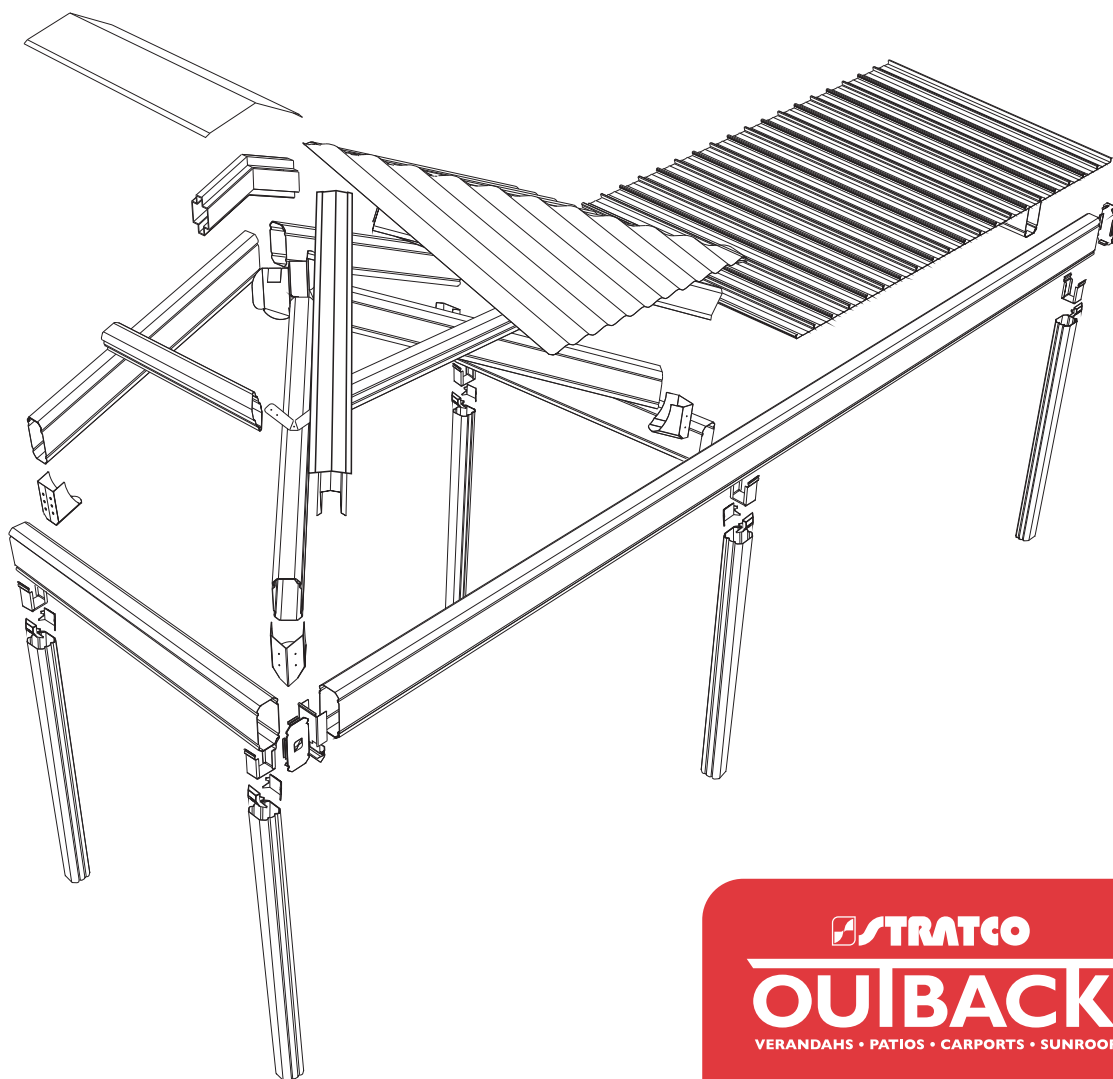

**RIDGE KNUCKLE**  
Slots inside the gable rafters to form connection at the ridge.

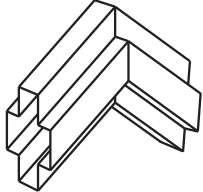

**RAFTERS**  
Gable Rafters consist of pre-cut 120 Outback® beam.

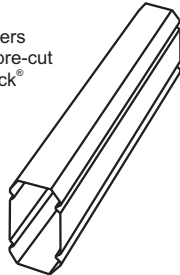

**RAFTER TO VALLEY BRACKET**  
This bracket fastens the rafter to the valley beam.

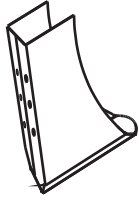

**SPACERS**  
Are used to prevent the 150 attachment beam from crushing.

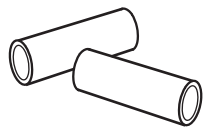

**SOAKER FLASHING**  
The soaker flashing water proofs the rear of the gable and conceals the existing house gutter.

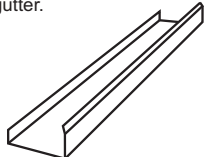

**22° or 30° END RAFTER BRACKET**  
Connects rafters to header beam on an infill gable.

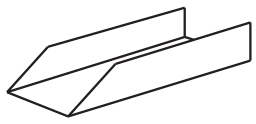

**END STRUT**  
The gable infill is supported by the end strut, which consists of a section of post.

**22° or 30° END STRUT PLATE**  
Secures the end strut at the ridge.



**HEADER BEAM BRACKET**  
Connects end strut to header beam on an infill gable.

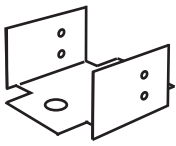

**RIDGE CAP**  
This flashing covers the roof sheets at the gable ridge and the Gazebo End hips.

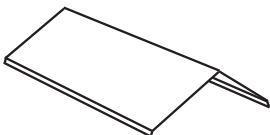

**BARGE CAP**  
The barge cap covers the area where the deck finishes at portal frame.

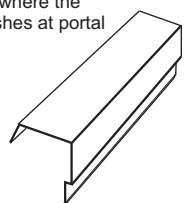

**SCREWS AND RIVETS**  
Fastener types vary depending upon the connection, ensure correct fixings are used.

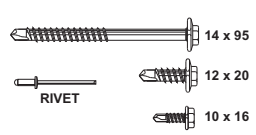

**BOLTS**  
Fastener types vary depending upon the connection, ensure correct fixings are used.

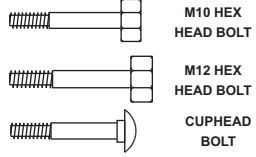

**PERIMETER BRACKET**  
This bracket fastens the rafters to the hip fascia beam.

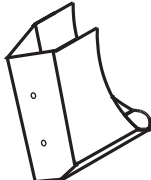

**ANGLED INLINE CONNECTORS**  
90° Angled Purlin Connector.



**PURLIN INTERSECTION COVER**  
Fastened to hip rafters to cover purlins and attach deck.

**TEMPLATE**  
Used to mark the purlin cover for cutting around purlins.

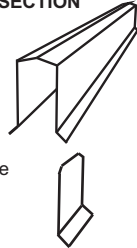

**BEAM TO BEAM BRACKET**  
Connects horizontal beams.

**BEAM FILLER**  
Fills gap between intersecting beams.

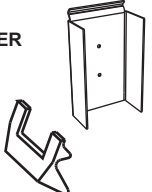

**PURLINS**  
Purlins provide support for cladding.

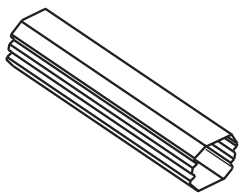

**HEADER FLASHINGS**  
Runs along header beam to neatly finish the base of infill panels.

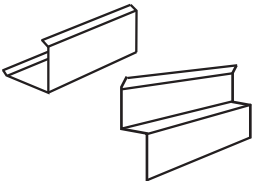

**APEX BRACKET**  
This bracket fastens the hip rafters to the apex of the gable frame.

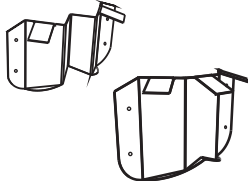

**POST BRACKET**  
Connects post to beam.

**POST CAP**  
Fills gap between post and beam.

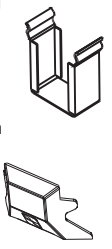

**PANEL STRIPS**  
Decorative strips fixed to infill panels.

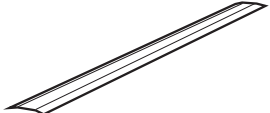

**INFILL PANEL**  
Cut to suit gable end frames.

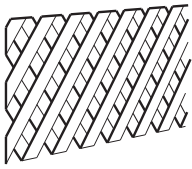

**FINIAL**  
Provides decoration at the apex of the gable end frame.



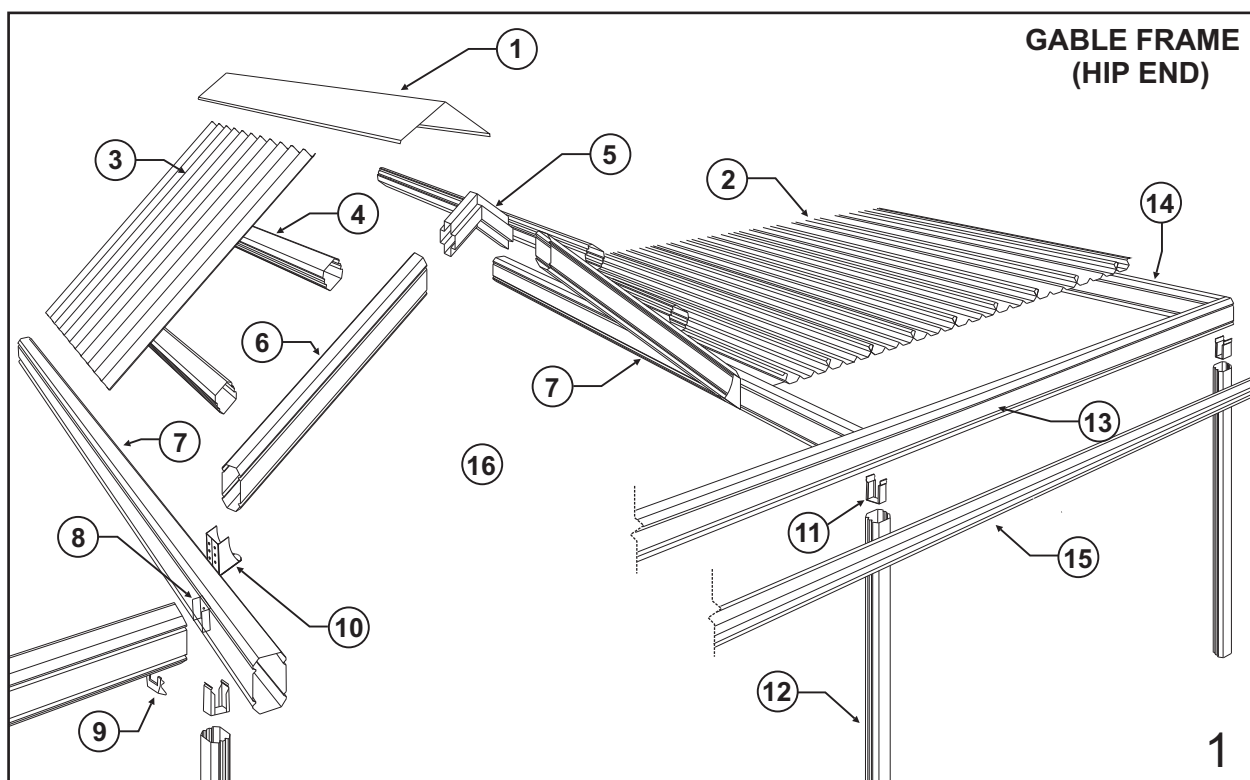

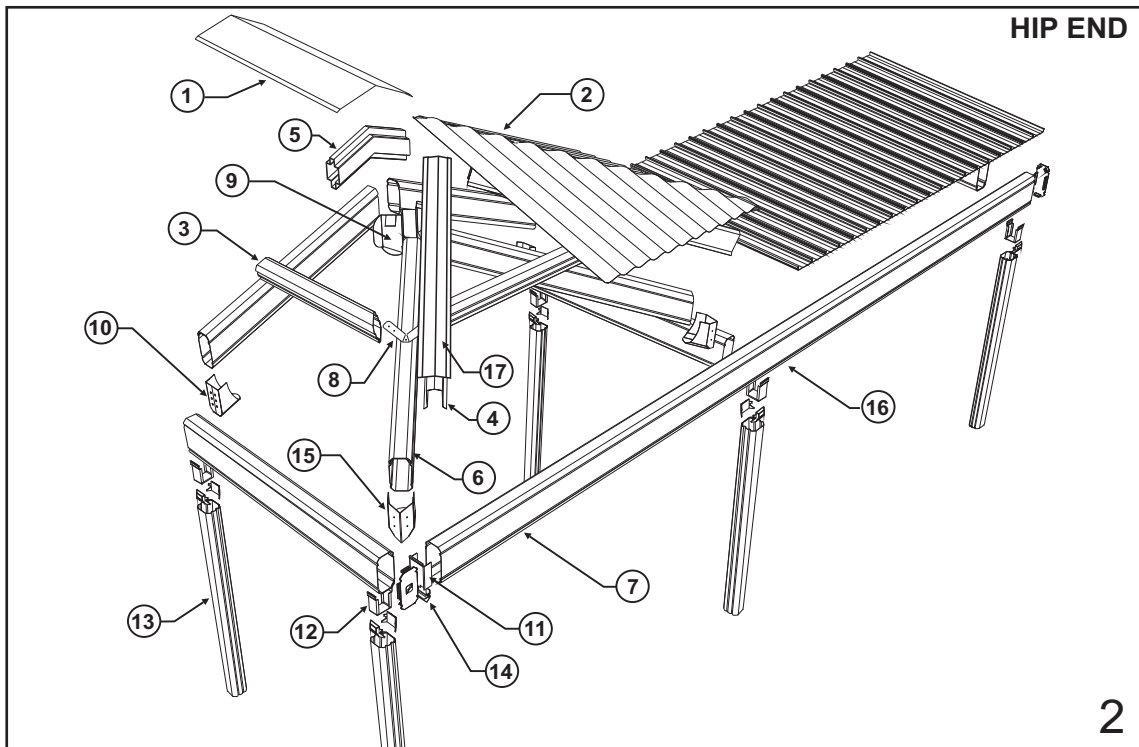

- |  |                            |
|--|----------------------------|
| ① Ridge Cap                                    | ⑩ Rafter to Valley Bracket |
| ② Outback® Deck                                | ⑪ Post Bracket             |
| ③ Polycarbonate Sheet,<br>Outback® Deck or CGI | ⑫ Post                     |
| ④ Purlin                                       | ⑬ Front Fascia Beam        |
| ⑤ Ridge Knuckle                                | ⑭ End Fascia Beam          |
| ⑥ Rafter                                       | ⑮ Gutter                   |
| ⑦ Valley Beam                                  |                            |
| ⑧ Beam to Beam Bracket                         |                            |
| ⑨ Notched Beam Filler                          |                            |

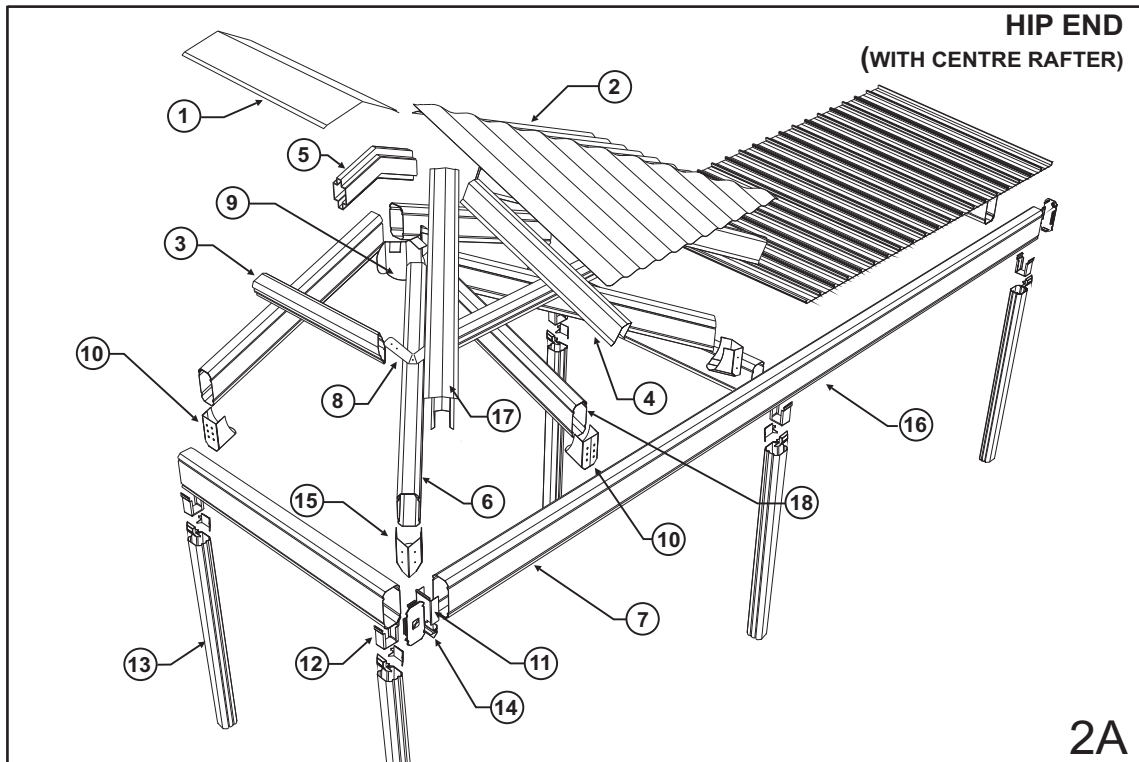

2

- |  |                            |
|--|----------------------------|
| ① Ridge Cap                                    | ⑩ Rafter to Valley Bracket |
| ② Polycarbonate Sheet,<br>Outback® Deck or CGI | ⑪ Beam to Beam Bracket     |
| ③ Purlin                                       | ⑫ Post Bracket             |
| ④ Purlin Intersection Cover                    | ⑬ Post                     |
| ⑤ Ridge Knuckle                                | ⑭ Notched Beam Filler      |
| ⑥ Hip Rafter                                   | ⑮ Perimeter Bracket        |
| ⑦ Hip Fascia Beam                              | ⑯ Front Fascia Beam        |
| ⑧ 90° Angled Purlin Connector                  | ⑰ Hip Support Flashing     |
| ⑨ Hip Apex Bracket                             | ⑱ Centre Hip Rafter        |



2A

Note: A centre hip rafter will be required on units when the opening exceeds 3600mm up to a wind speed of W41C and when the opening exceeds 2400mm for wind speeds W50N - W60C.

These materials are needed to complete the job, but are not included in the basic kit price. (they must be purchased as extra items, and their quantities specified):

- Rafter strengthening brackets and channels to suit 150 beam attachment for attaching gable to house.
- M12 bolts and nuts for fixing strengthening brackets to the rafter.
- M12 bolts and nuts for fixing 150 attachment beam to strengthening brackets.
- Fascia Brackets for attaching gable on end to house.
- M10 coach bolts and nuts for fixing fascia brackets to the house rafter.
- M8 masonry anchors for fixing Wall Brackets to masonry.

- 12x25 type 17 teks for fixing Suspension Brackets to timber.
- 10x16 hex head screws for fixing Suspension Brackets to steel fascia.
- Cover flashings (measurements required).
- Box gutter (measurements required).

**OPTIONAL EXTRAS**

These items are available at request:

- Infill Panels
- Panel Strips
- Finial
- Soaker Flashing in lieu of Header Flashing
- Purlin Intersection Cap

**1.0 INTRODUCTION**

Please read these assembly instructions thoroughly before commencing the construction. Double check all dimensions, levels and bolting locations before cutting, screwing or bolting structural members. It is recommended that the persons erecting the structure have had some previous building experience, because some modifications to the existing house structure are required.

**2.0 ATTACHING TO AN EXISTING STRUCTURE**

The builder or council is to ensure the existing house/structure is of a suitable structural integrity and complies with all the relevant Australian Building codes and standards. For more information regarding the suitability of the house structure to accommodate the Stratco Attached Multispan Gable, consult a structural engineer or a building authority. It is the builders responsibility to ensure that the existing house roof structure is strengthened correctly.

Refer to section 2.1 if attaching Multispan Gable on it's side to a house, section 2.2 if attaching on it's end to a house or refer to both sections if attaching the gable on it's side and end.

**2.1 ATTACHING ON SIDE TO HOUSE**

A Stratco Multispan attached on it's side to a house is attached to the existing eaves overhang at the fascia.

The first objective in the construction is to fix a structural side beam along the fascia or wall, to which the Gable Unit is attached.

Most existing houses have not been designed for the attachment of portal framed gables to their side, therefore additional strengthening of the house rafters must be performed.

In order to strengthen the existing house rafters, the roof tiles or roof sheets need to be lifted, to expose the roof frame. Steel rafter brackets and channels are then bolted along the house rafters. Refer to section 2.1.1.

A 150 mm Outback® beam is bolted to the strengthening brackets at the fascia. Once the 150 attachment beam is secured to the house the Gable Unit can be erected and fastened to the beam.

**2.1.1 RAFTER STRENGTHENING**

The first step is to determine the number of rafters which need to be strengthened, and their location relative to the unit. You will have to lift some roof tiles or roof sheets to discover the rafter positions and spacings. The number of rafters which need to be strengthened is determined by the builder.

**Note:** It is the builders responsibility to ensure the existing rafters and fascia are adequately reinforced and strengthened to accommodate any additional attached structure. The reinforcing method must be approved by the appropriate council and engineer.

Use an adjustable rafter strengthening bracket and one channel for eaves overhangs up to 450 mm. Use an adjustable rafter strengthening bracket and two channels for eaves overhangs over 450 mm and up to and including 600 mm, as shown in figure 4.

The adjustable rafter strengthening bracket is shown in figure 3. Please note that this bracket may not be suitable for applications where the front face of the house gutter is higher than 120 mm. In these cases please contact Stratco for alternative solutions.

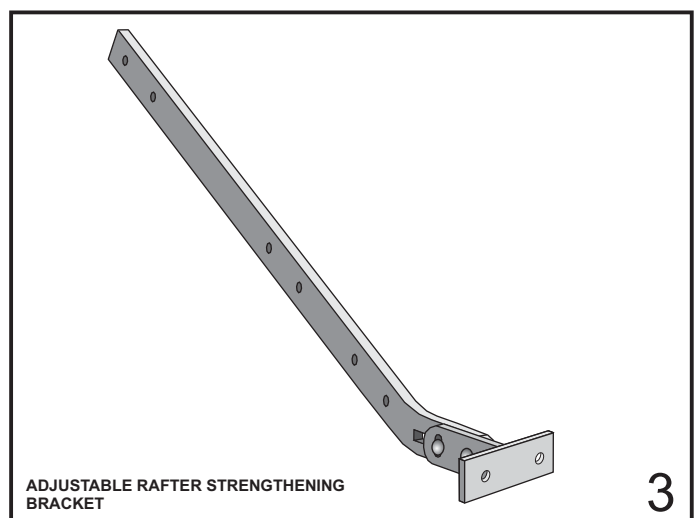

ADJUSTABLE RAFTER STRENGTHENING BRACKET

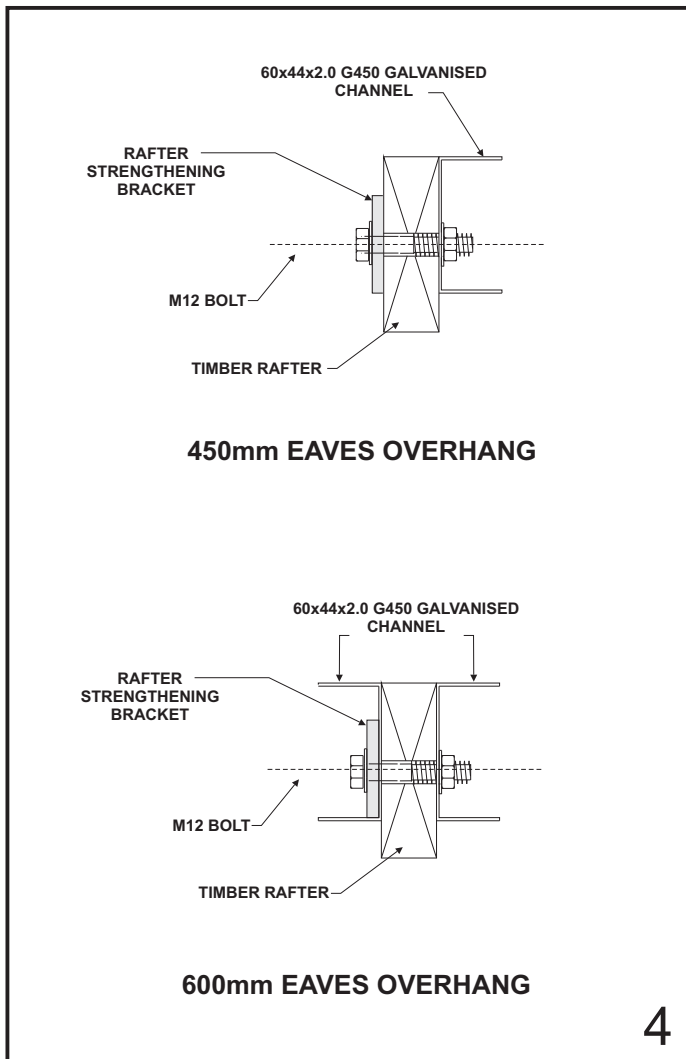

## Fixing Rafter Strengthening Brackets and Channels

The adjustable rafter strengthening bracket allows for an adjustment of pitch in the range of 15 to 30 degrees. The distance the bracket extends past the fascia is also adjustable to allow for standard gutters or box gutters with a width of up to 200mm.

In conjunction with rafter strengthening brackets, channels are fixed to the side of the house rafter (Figure 4). The bottom end of the channel will be located at the base of the house rafter. Holes should be marked and pre-drilled in the channels to suit the location of existing holes in the bracket. The channel will extend beyond the bracket so additional holes are to be drilled in the channel at approximately 500mm centres.

Initially the bracket T piece shall be fixed to the bracket arm with two M12 cup head bolts (hand tighten only), a spring washer is to be located between the standard M12 washer and nut (Figure 5). Mark the position of the bracket on the fascia and notch a rectangular hole in the fascia allowing the bracket to be fed through the front of the fascia. The hole may need to be enlarged slightly if the M12 cup head bolts interfere with the fascia.

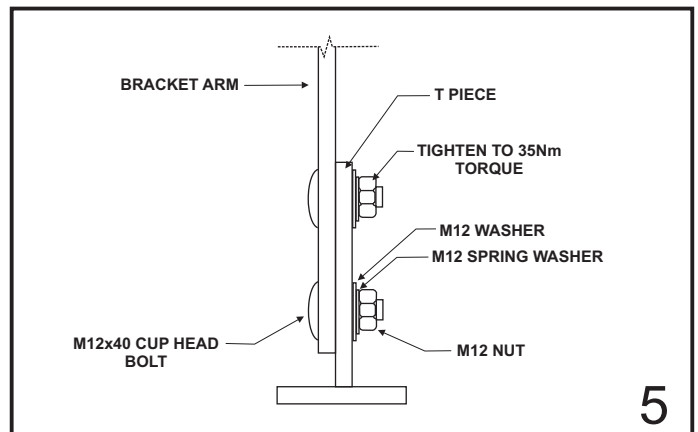

Insert the bracket through the fascia and fix with the channel(s) to the house rafter using M12 hex head bolts through the existing holes in the bracket and further up the channel(s) (Figure 7). Adjust the T piece so it is horizontal and has the appropriate extension past the fascia to allow for fixing of the attachment beam. T piece connection bolts are to be tightened to a minimum 35Nm torque.

Fix the bracket as close to the base of the gutter as possible (recommended distance 10mm from lowest end of gutter), as shown in figure 6.

The 150 attachment beam is to be fixed to the end plate to ensure the carport roof sheets drain into the existing house gutter (Figure 6).

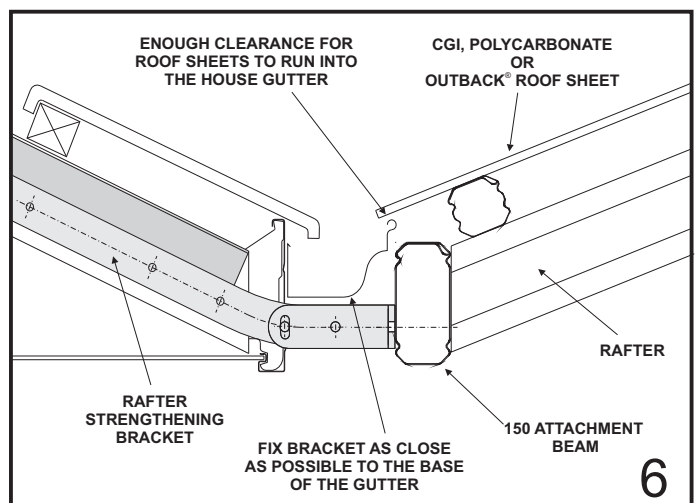

## Fixing the 150 Attachment Beam in Place

After fixing all the brackets and channels, the 150 beam is fixed in place.

Prop up the 150 beam in position with the double flange on top, the beam will need to be located at a height on the bracket which allows clearance between the gable roof sheets and the gutter. Fix to the end plates of the rafter bracket using two M12 bolts, with the bolt head on the 150 beam side. Insert spacers to prevent the beam from crushing, and bolt in position, using nuts and washers.

**Note:** Do not over tighten bolts as this can lead to a visible indentation due to the high gloss nature of the material. Refer to Figure 8 for fixing spacers.

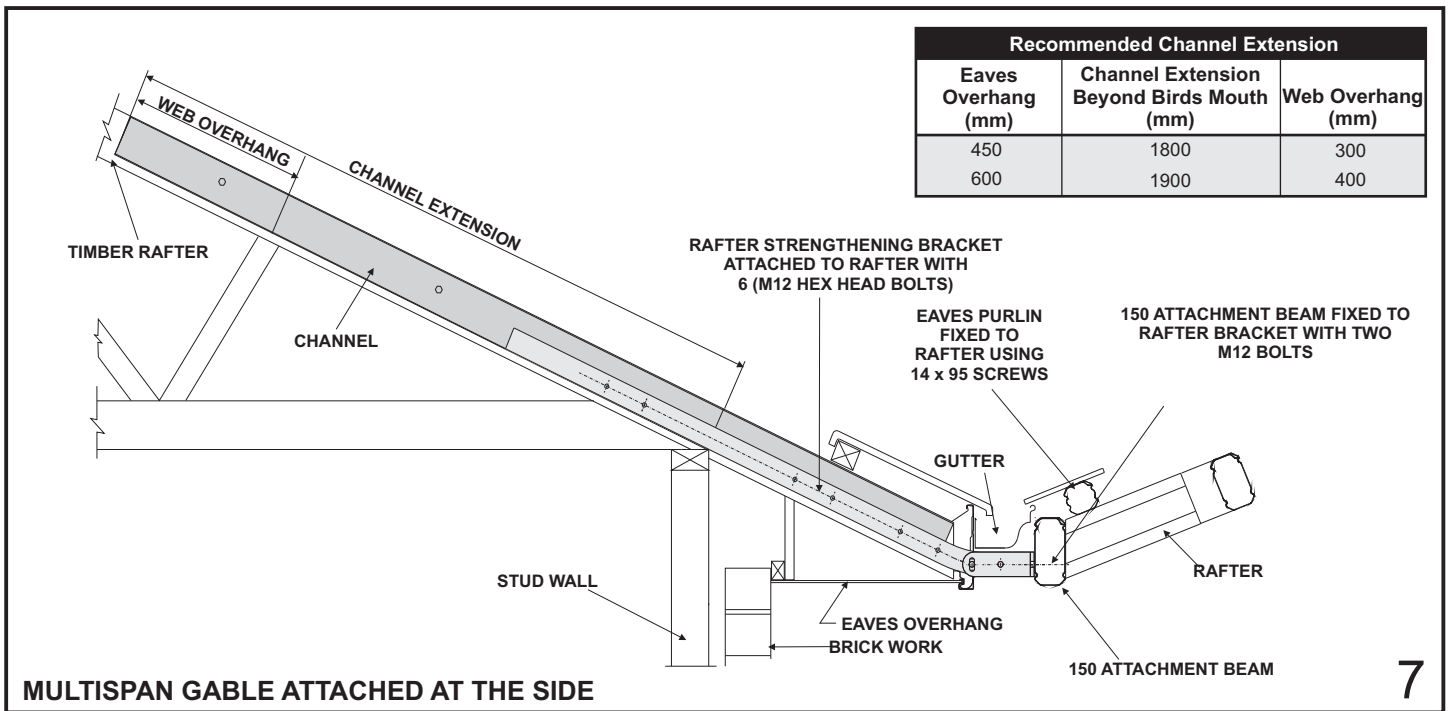

The 150 attachment beam becomes the base for the attachment of the Multispan gable unit. Figure 7 shows a unit attached at the side.

To insert spacers drill 11 mm holes through the 150 attachment beam. Then drill 16 mm holes on the outside face only, ie this time do not drill all the way through. This will allow the spacer to slide in, from the outside and stop at the other side as shown in figure 8.

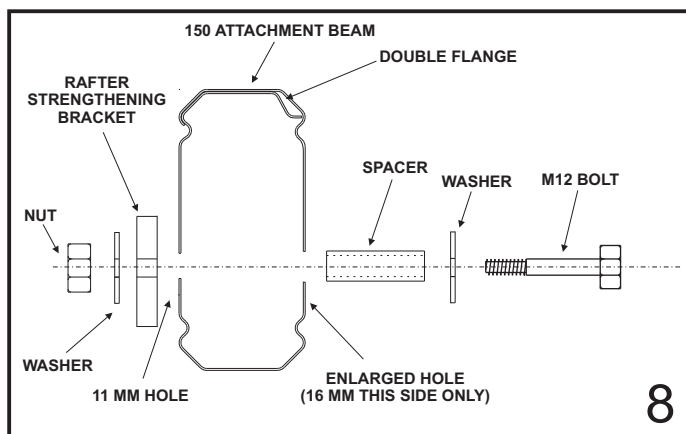

You would have ordered and received your custom made flashings to cover the exposed brackets and holes through fascia. Rivet flashings in place, figure 9 suggests a simplified flashing. You may however use your imagination and design a flashing that suits your individual taste.

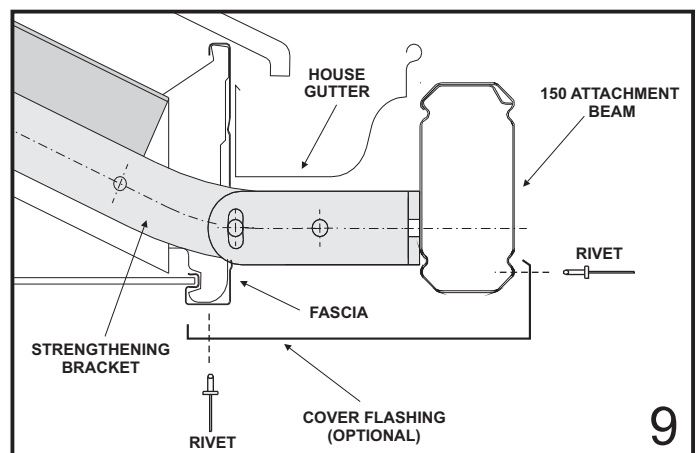

**Note:** It is the builders responsibility to ensure the existing rafters and fascia are adequately reinforced and strengthened to accommodate any additional attached structure. The reinforcing method must be approved by the appropriate council and engineer.

## 2.2 ATTACHING ON END TO HOUSE

If fixing a Multispan Gable on its end to a wall, two alternatives are available. Purlins are fixed directly to the wall using 68mm wall brackets and valley beams using 150 beam to wall brackets. This option will not require a rear gable frame and back channel is fixed to the wall to accommodate sheets running along the wall. The other alternative requires valley beams be fixed to the wall and a rear gable frame installed for fixing purlins. The rear gable frame will need to be slightly offset from the wall to allow the appropriate bracket fixing.

If fixing a Multispan Gable on its end with suspension brackets to a fascia (Figure 10), typically a soaker flashing is used. In this case the gable rafter at the rear of the unit

is to be 153mm from the house fascia in order to accommodate a standard soaker flashing (refer Figures 23 and 24).

**Note:** If your house gutter is wider than 150mm a custom made soaker flashing will need to be ordered and the rafter set back adjusted to suit.

If fixing a Multispan Gable on its end to an attachment beam, elevated to the existing house gutter height, the attachment beam is to be as close as possible (within 5mm) to the outside face of the gutter (Figure 25). The 150mm attachment beam is fixed to rafter strengthening brackets as detailed in section 2.1.1.

### 2.2.1 FASCIA STRENGTHENING

Steel fascia brackets are generally fastened at 1200mm centres to fascia and rafters (Figure 10). It is the builders responsibility to determine the adequacy of the fascia and rafters and the frequency of brackets for each individual situation.

**Note:** It is the builders responsibility to ensure the existing rafters and fascia are adequately reinforced and strengthened to accommodate any additional attached structure. The reinforcing method must be approved by the appropriate council or engineer.

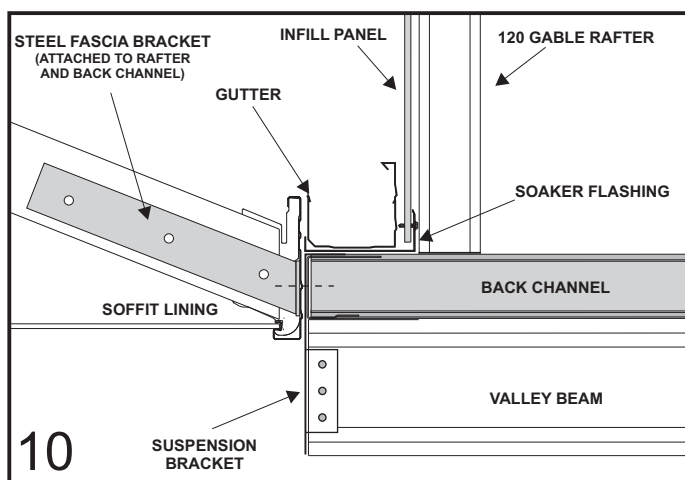

### 3.0 GABLE FRAME ASSEMBLY

**IMPORTANT:** Ensure that the double flange portion is at the top when installing all beams and rafters.

**Note:** The rafters are supplied pre-cut and drilled at the ridge as shown in figure 11.

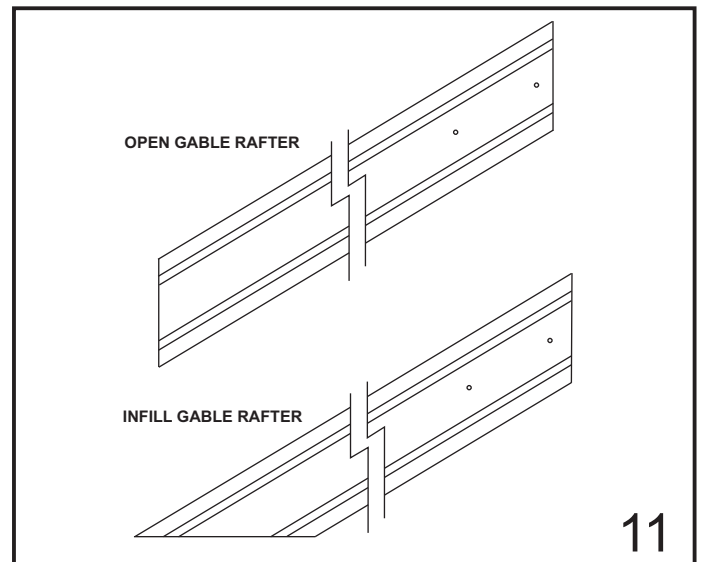

Insert ridge knuckle into the pre-cut rafters and screw together using two 12x20 hex head self drilling screws both sides of each rafter and two 12x20 hex head self drilling screws through the top (double flange side) of each rafter.

Pilot holes indicate screw locations as shown in figure 12. Make sure that the two ends are flush at the connection, leaving no gaps.

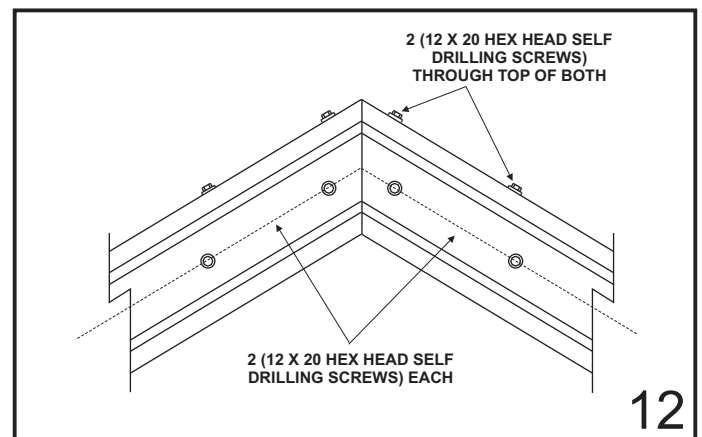

Measure the distance between rafter ends, O, to check valley beam spacing (Figure 13).

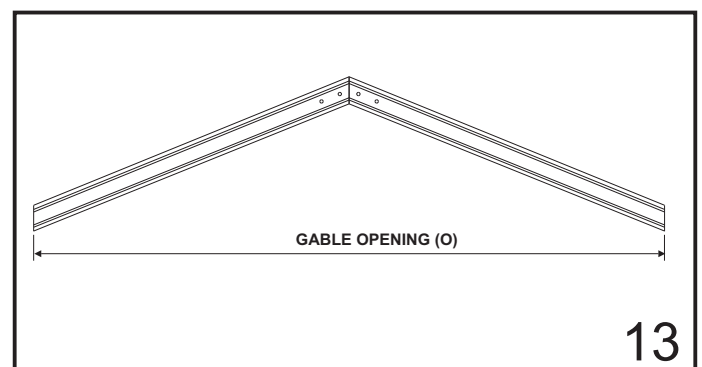



### 3.1 APEX BRACKET

The Hip Apex bracket is to be fixed to the front face of the front gable frame at the apex. The bracket is to be located so the bottom edge of the apex bracket is in-line with the top edge of the bottom chamfer of the gable frame rafters. The apex bracket is to be located centrally at the apex and fixed through the pre-drilled holes using 12x20 hex head screws (Figure 14).

If a centre hip rafter is required an apex bracket with three rafter tabs will have been supplied.

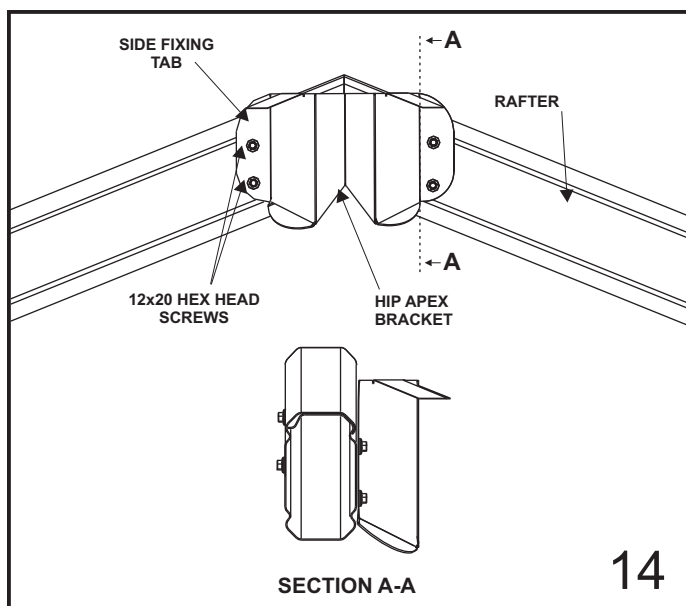

A Hip Apex Flashing is secured with rivets behind the apex bracket and will cover any gaps created by purlin intersection covers (Section 9.3).

### 4.0 VALLEY BEAM ASSEMBLY

#### 4.1 SIDE ATTACHED

For side attached units fix the rafter to valley brackets to the 150 beam (150 attachment beam will be considered a valley beam) at the correct rafter positions (refer Section 6) using six 12x20 hex head screws per bracket. Please note the bottom face of the bracket lines up with the bottom of the lower groove in the valley beam (Figure 15). Check positions before drilling.

If any intermediate columns are required, measure the valley beam marking where they meet. Fasten post brackets as explained in 'Outback Flat Attached Verandahs, Patios & Carports' under "FRONT FASCIA BEAM".

Support the second valley beam at the spacing determined in part 3.0 on adjustable construction props.

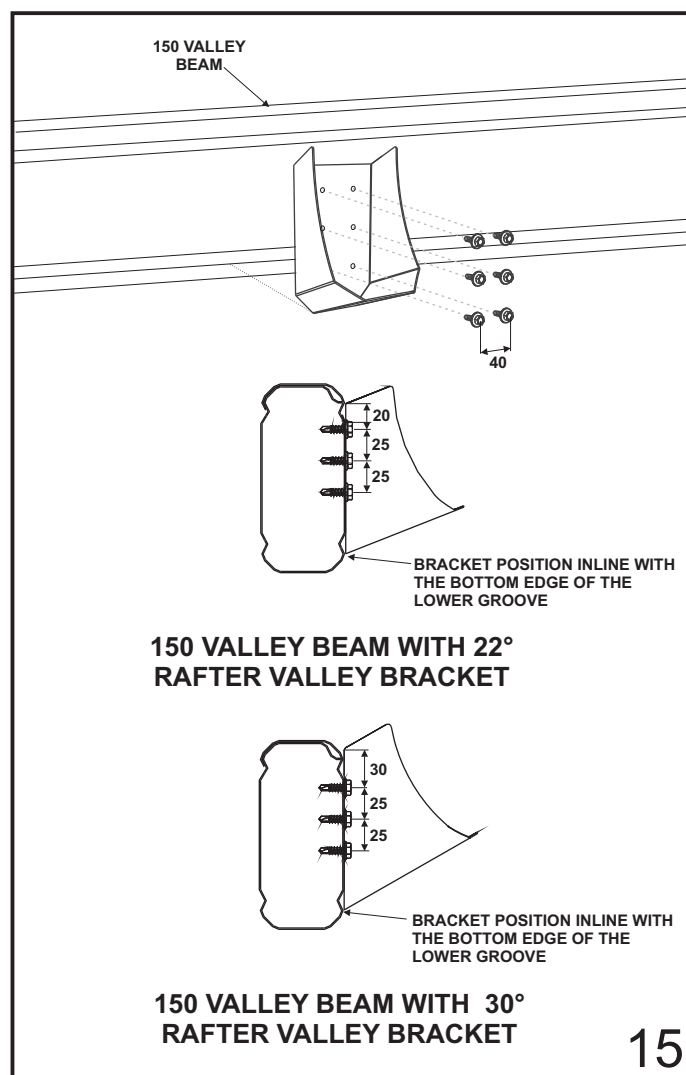

#### 4.2 END ATTACHED

For units attached on the end to a wall, wall brackets are positioned at either side of the gable opening at the spacing determined in part 3.0. The first bracket is fastened to the wall with two M8x65mm masonry anchors. The curved legs of the bracket are located at the top and the highest point of the wall bracket will be 15mm below the top of the beam (Figure 16).

Pivot the first valley beam (double flange on top) up into the wall bracket so the curved legs locate against the top flute of the beam. The valley beam is fastened to the wall bracket with 10x16 hex head screws in the pre-drilled holes while the opposite end is supported on adjustable construction props.

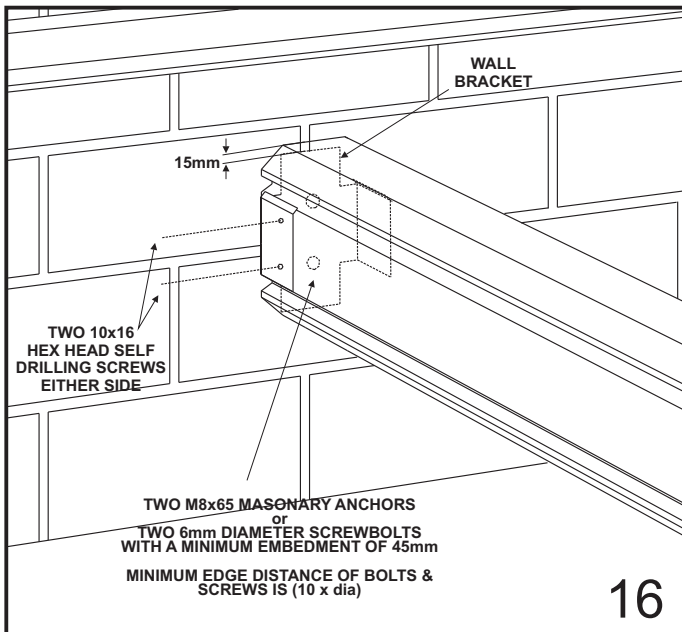

For units attached on the end to a fascia, suspension brackets are positioned at either side of the gable opening at the spacing determined in part 3.0. The top tab of the suspension bracket must be located between the fascia and back channel. A minimum of two 10x16 hex head screws are fixed through back channel, suspension bracket and steel fascia while two 12x25 type 17 screws are used to fix through back channel, suspension bracket and timber (Figure 17).

**Note:** If back channel is not present, (ie, no adjacent flat roof) locate washer plate behind steel fascia at suspension bracket. Fix through bracket, fascia and plate.

The first valley beam is fastened into the suspension bracket with 10x16 hex head screws through the dimples while the opposite end is supported on adjustable construction props.

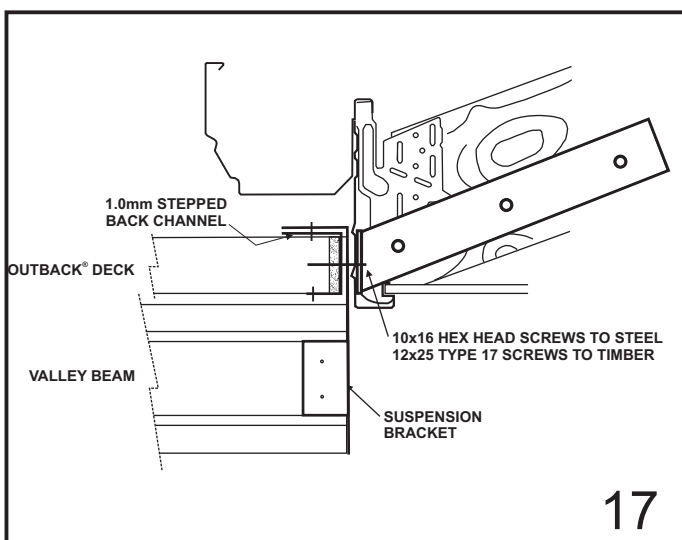

The first valley beam is fastened over the beam to beam bracket with two 10x16 hex head screws either side while the opposite end is supported on adjustable construction props.

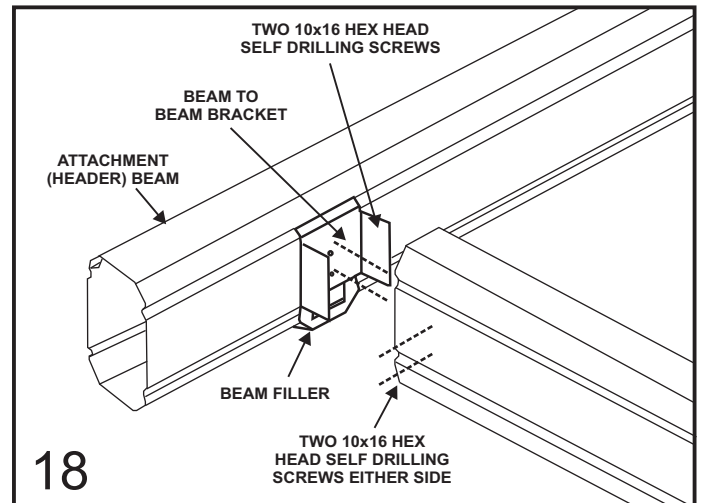

If any intermediate columns are required measure the valley beam marking where they meet. Fasten post brackets as explained in the installation guide 'Outback Flat Attached Verandahs, Patios & Carports' under "FRONT FASCIA BEAM". This can be done before valley beams are fixed in place.

Support the second valley beam on adjustable construction props but do not fix to the wall, fascia or attachment beam until the front gable frame has been attached.

Fix the rafter to valley brackets to the 150 valley beams at the correct rafter positions (refer Section 6). Fixing details as shown in section 4.1.

## 5.0 HIP FASCIA BEAM

Either the hip fascia beam is connected to the valley beam or visa vera depending on the overall unit design (refer Figure 19). Post brackets are to be fastened to the appropriate beam so posts can be located directly in the corner of the Hip End. Refer to 'Outback Flat Attached Verandahs, Patios & Carports' for post bracket fixing details.

Attach the beam to beam bracket to the beam which is being attached to using two 12x20 hex head screws. Slide the other beam into the beam to beam bracket and fix using two 12x20 hex head screws to the beam face on the opposite side of the hip, this is to allow for the perimeter bracket (Section 7.0). Support the first hip corner on an adjustable construction prop.

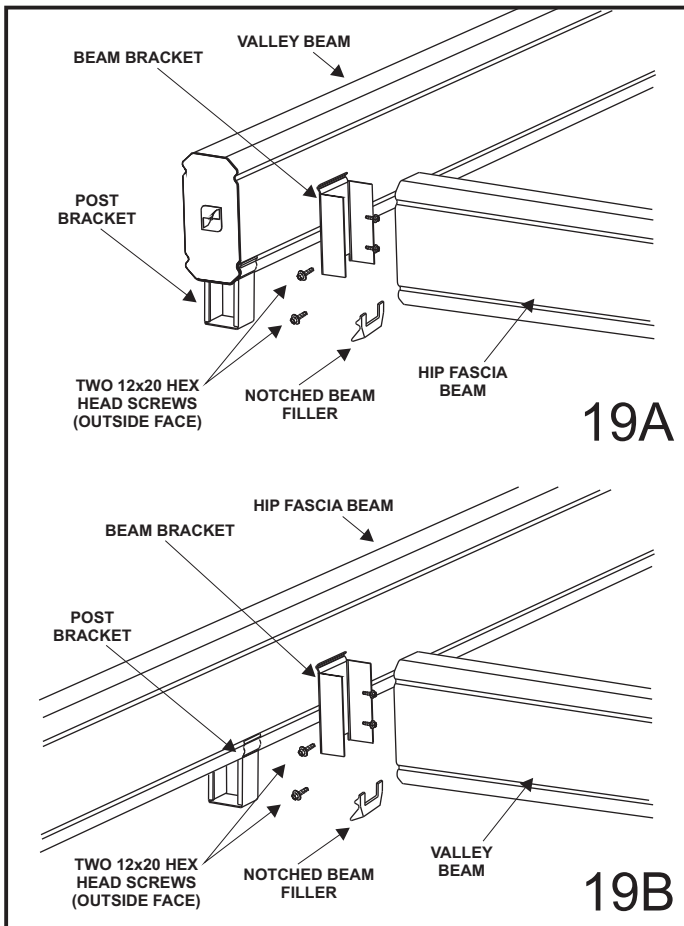

Repeat this process on the other side of the Hip End to complete the perimeter.

## 6.0 GABLE FRAME CONNECTION

**Note:** Be aware that gable frames are always 120 beams and valley beams are always 150 beams for Multispan units with a hip end.

### 6.1 GABLE FRAMES (Figure 1)

The front gable frame will need to be set back from the front of the valley beams to accommodate the hip end. Refer to Figure 20 and Table 1 for set back distance.

The rafter to valley brackets will have been attached to the valley beams using six 12x20 hex head screws to attach the bracket to the valley beam (Figure 15, Section 4) at the location determined from Table 1 (Figure 20).

OPENING, O	A (Set Back)
1200	600
1500	750
1800	900
2100	1050
2400	1200
2700	1350
3000	1500
3300	1650
3600	1800
3900	1950
4200	2100
4500	2250
4800	2400
5100	2550
5400	2700
5700	2850
6000	3000
6300	3150
6600	3300

**Table 1**  
Interpolation may be used to determine values between those shown.  
All lengths in millimetres (mm).

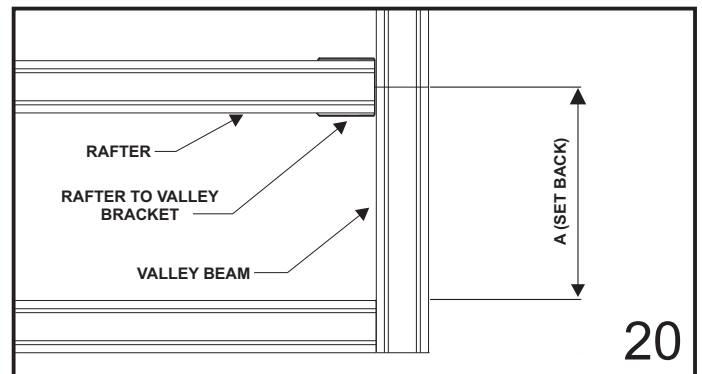

Fix the gable rafters to the rafter to valley brackets with two 12x 20 hex head screws either side (Figure 21).

If attached on the end, attach the second valley beam into the wall or suspension bracket.

**Note:** If the unit includes rear infill a rear header beam is required and must be installed before fixing the second valley beam in position, refer section 6.2.

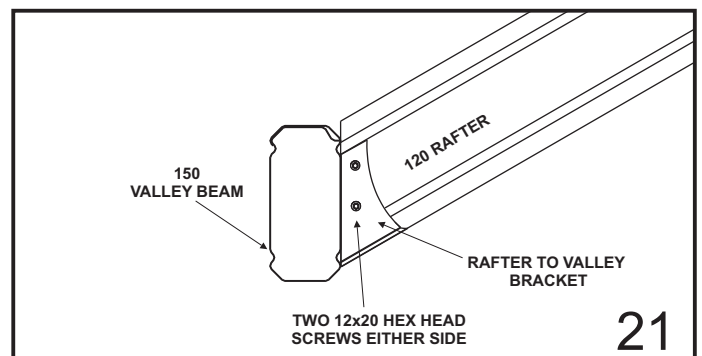

Intermediate frames should be spaced evenly and fixed into rafter to valley brackets as previously described.

A rear gable frame without a header beam is fixed as per an intermediate frame.

## 6.2. REAR INFILL

A rear header beam will be required if the unit includes infill to the rear gable frame. For units attached at the rear with suspension brackets, the rear header is fixed between valley beams using beam to beam brackets. If fixed at the rear to an attachment beam (Figure 25), the attachment beam becomes the header (valley beams are fixed to the header beam) and if attached on the side the rear header is fixed to the attachment beam with beam to beam brackets.

Attach end rafter brackets to the rear header beam at spacing, O, as determined in section 3 using three 10x16 hex head self drilling screws (Figure 22).

Fasten the rafters that form the end gable frame over the end rafter brackets with a minimum of two 10x16 hex head screws either side (Figure 22).

Refer section 14 for details of fixing infill panels to gable frames.

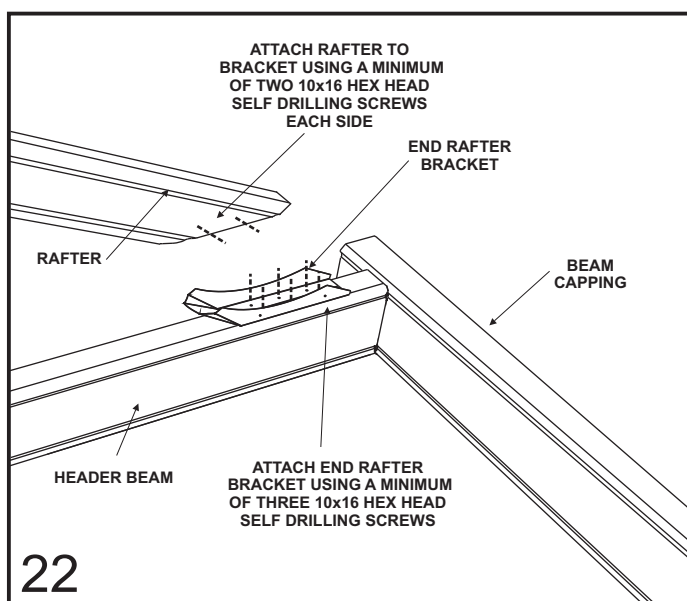

### 6.2.1 SOAKER FLASHING

In the case of a rear infill panel, a soaker flashing is used to conceal the existing house gutter, waterproof the rear end of the gable and neatly finish the base of the infill panel (Figure 23).

The rear gable frame and header beam should be positioned 153 mm from the house fascia in order to accommodate the standard soaker flashing which is optional with the Outback® unit (Figure 24). The frame is fixed on the rear header over end rafter brackets

Fix the standard soaker flashing into position on top of the back channel and underneath the gutter. Infill panels must

be fixed with split tail soft pull rivets at 500mm centres a minimum of 20 mm above the pan of the soaker flashing. This will reduce the possibility of moisture being absorbed into the sheet.

Refer section 14 for details of fixing infill panels to gable frames.

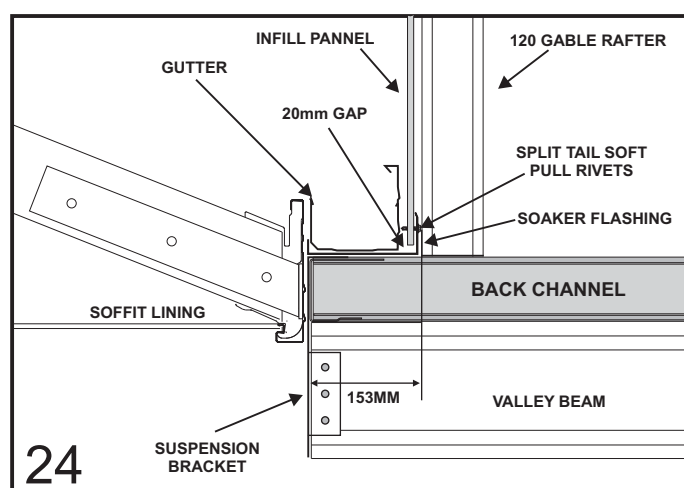
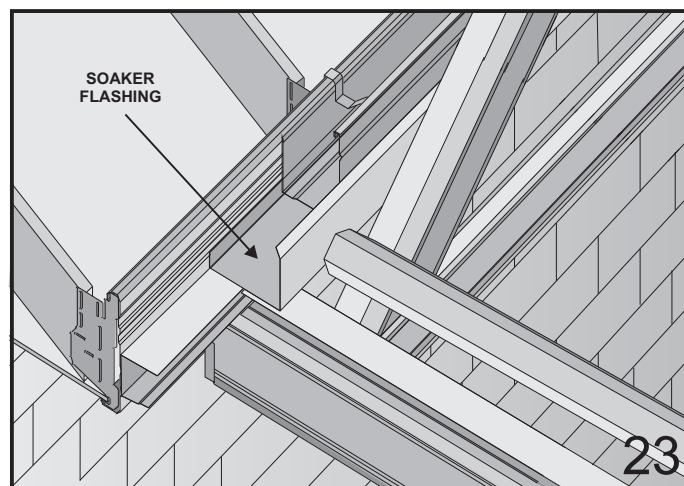

#### Note:

1. If your house gutter is wider than 150 mm a custom made soaker flashing will need to be ordered to the required dimensions. The rafter set back will need to be adjusted to suit.
2. Do not form stop ends at either end of the soaker flashing.
3. Soaker flashing is not to come in contact with the base of the house gutter.

### 6.2.2 HEADER FLASHING

When a gable is fixed at the rear to an attachment beam, elevated to the existing house gutter height, typically a header flashing is used in conjunction with the rear infill. In this case, the rear attachment beam is considered a header, and along with the rear gable frame is fixed as close as possible (within 5mm) to the existing gutter in order to accommodate the header flashing. The gable frame is fixed on the rear header over end rafter brackets (Figure 22).

Fix the header flashing into position over the existing gutter lip with rivets. Infill panels are located behind the header flashing and fixed with split tail soft pull rivets at 500mm centres (Figure 25).

Refer section 14 for details of fixing infill panels to gable frames.

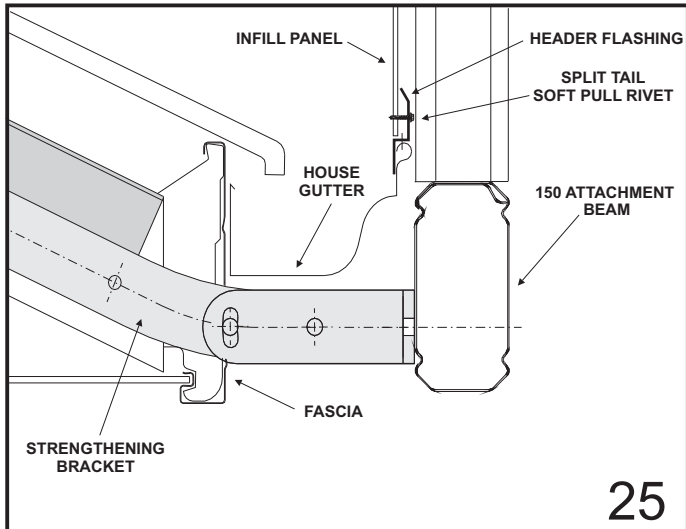

25

## 7.0 PERIMETER BRACKETS

Perimeter brackets are to be located at the internal join of the hip fascia and valley beams so the bottom face of the bracket is in-line with the bottom of the lower groove in the beams (Figure 26). Brackets are to be fastened to the hip fascia beams using four 12x20 hex head screws through the pre-drilled holes.

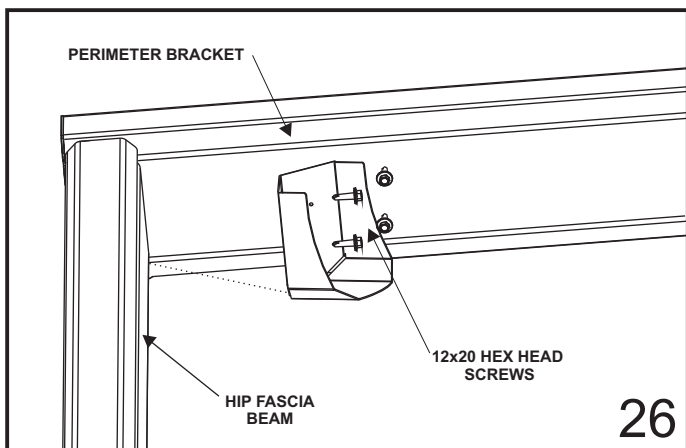

26

## 8.0 HIP RAFTERS

Having all the Perimeter Brackets in place will allow hip rafters to be located. It is important that rafters are firstly fixed at the apex, position rafters over the apex bracket tabs so the cut face of the rafter is flush with the face of the bracket. Two 12x20 hex head screws are used to fix the rafter to the tab with the first screw being located 20mm from the front face of the bracket and the second 20mm from the first screw (Figure 27).

If a centre hip rafter is required a rafter to valley bracket is to be fixed mid span of the hip fascia beam. Locate so the

bottom face of the bracket is in line with the bottom of the lower groove in the beam. Fasten with four 12x20 hex head screws.

The same method (as for hip rafters) is used to fix the centre hip rafter at the apex.

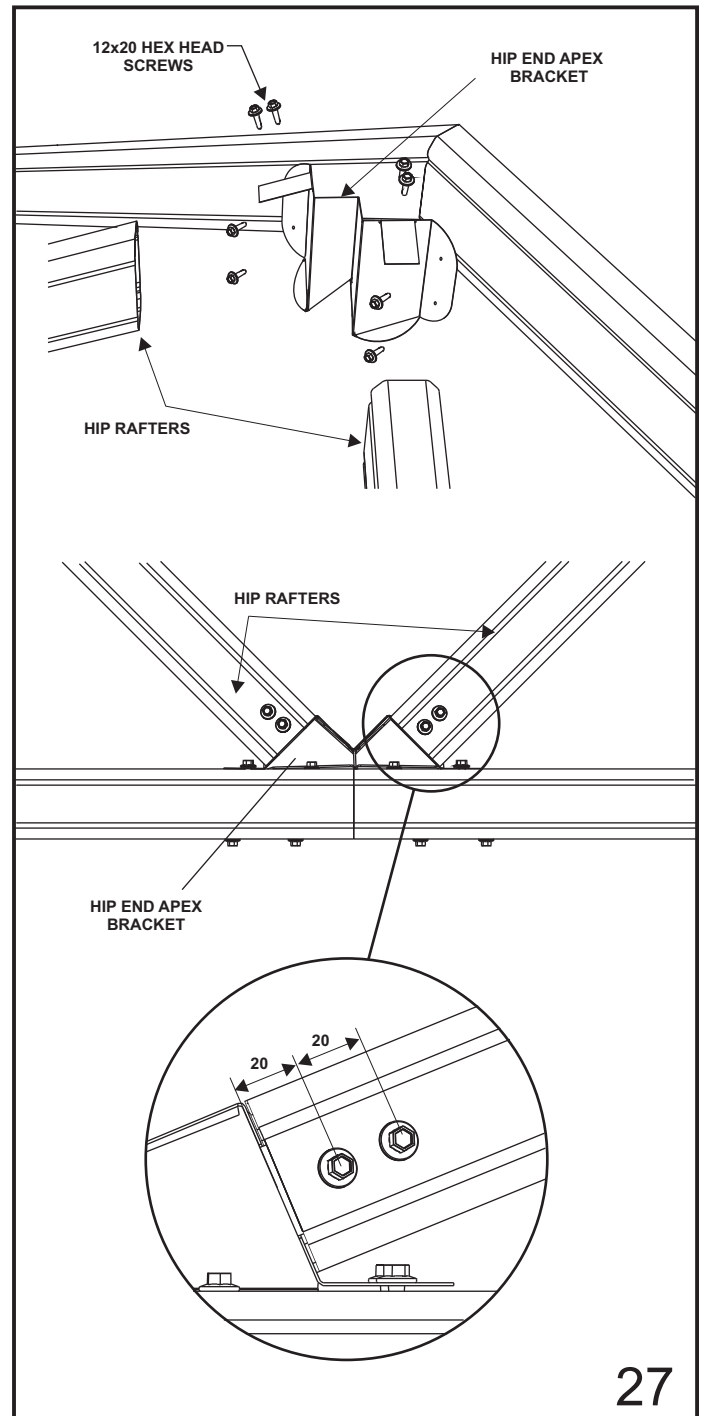

27

With all hip rafters fixed at the apex they can be fastened to the perimeter brackets. Fix rafters through the base of the perimeter brackets using two 12x20 hex head screws at a minimum spacing of 30mm. As a small tolerance is allowed for at this bracket it is important that the screws are located at least 20mm from the bracket edge and the bottom edge of the rafter (Figure 28).

To fix a centre hip rafter to the rafter to valley bracket use two 12x20 hex head screws either side.

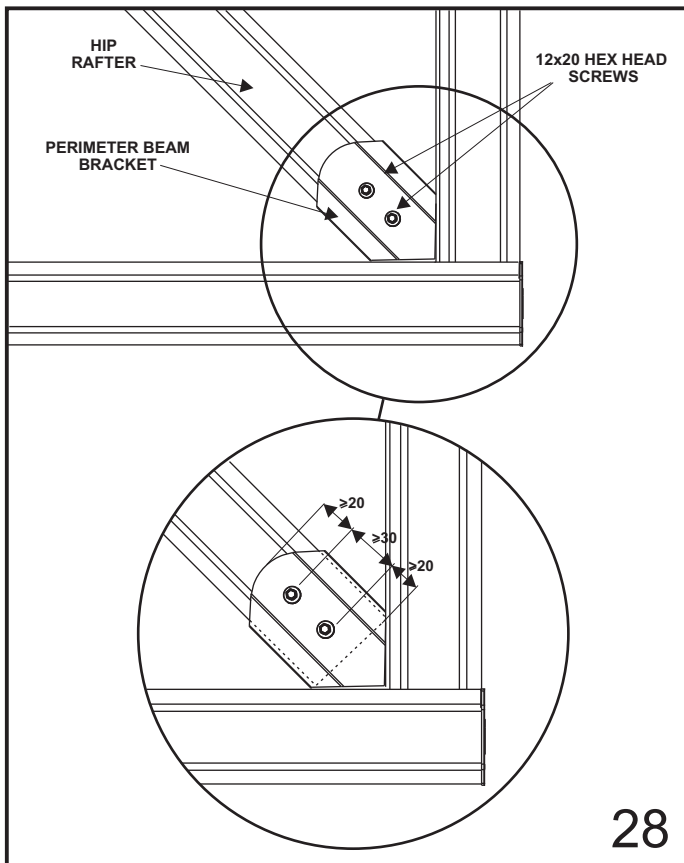

28

## 9.0 PURLINS

### 9.1 CUTTING PURLINS

The location of all the purlins must be known before any purlins are to be cut. The top purlin is positioned a maximum of 100mm from the gable ridge (Figure 29) and ends at the front edge of the gable frame on either side. The end of this purlin is cut straight to be left flush with the top of the rafter chamfer (Figure 29).

The lowest purlin shall be a maximum 50mm from the valley beam (Figure 29) and any intermediate purlins are spaced evenly on rafters, ensuring maximum recommended deck end spans are not exceeded. Both the lowest purlin and intermediate purlin/s will follow the shape of the hip end and therefore purlins will need to be mitred at 45° to length to suit this shape. The highest edge of the hip end purlins will end at the centre of the top face of hip rafters. Refer to Figure 30 for further details.

**Note:** It is recommended the three lowest purlins around the front of the gable end are set as low as possible on the hip rafters to eliminate any gap between purlins and gazebo fascia beams. It is not critical that the level of the lowest purlins exactly match the purlins adjacent to the valley beams.

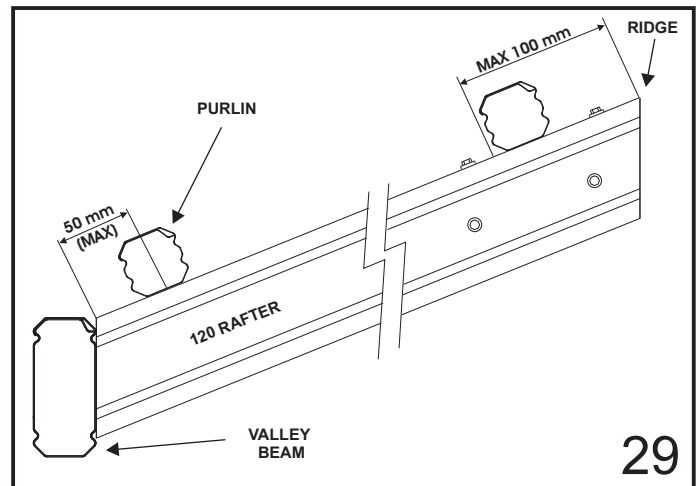

29

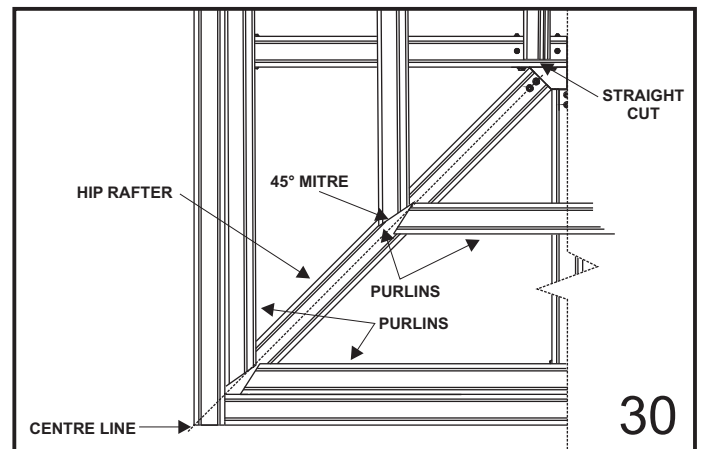

30

### 9.2 ATTACHING PURLINS

Where purlins are continuous over rafters they are fixed in position using 14x95 hex head self drilling screws. If it is necessary for purlins to be broken over standard gable frames (ie, purlins continue in the same direction past a join) a 68mm in-line purlin connector is used.

**Note:** By drilling pilot holes and screwing through the top of the purlin before lifting it into position, the process of screwing into the rafters is made easier. Pilot holes should also be drilled through rafters at the fixing location.

In the case of purlin joins which occur over a hip rafter an angled purlin connector will be required. Fix purlins together using 12x20 hex head screws. A 14x95 hex head self drilling screw is fastened through the connection to hold purlins to the rafter (Figure 31). A gap will be noticed at the lower edge of the purlin join but this will not be seen after installation of the purlin intersection cover.

If purlins do not align (ie, lowest hip end purlin and lowest gable purlin) they may be screwed directly to hip rafters.

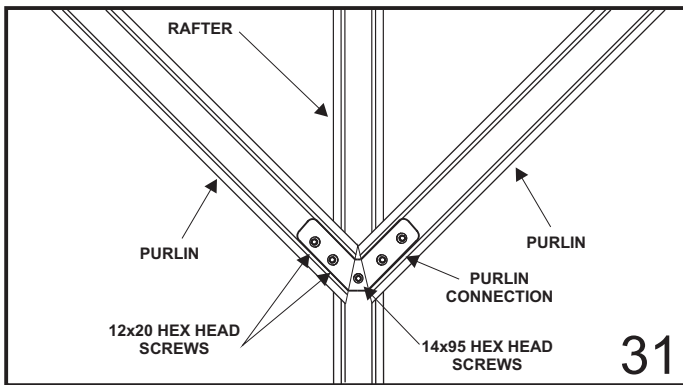

### 9.3 PURLIN INTERSECTION COVER

The purlin intersection covers are used to cover any gaps at purlin joins and also to attach decking. The location of purlins are to be marked along each side of the purlin intersection cover and the cover is then cut with tin snips to allow a tight fit over purlins. The template provided will allow the cut shape to be marked on the cover at the location of each purlin.

The purlin intersection cover is now riveted on either side to the chamfer of the rafter, rivets are to be located a maximum of 50mm from purlins on both the higher and lower sides and at spacings of no more than 300mm (Figure 32).

Each cover should be mitred at the apex to finish flush with the hip apex flashing.

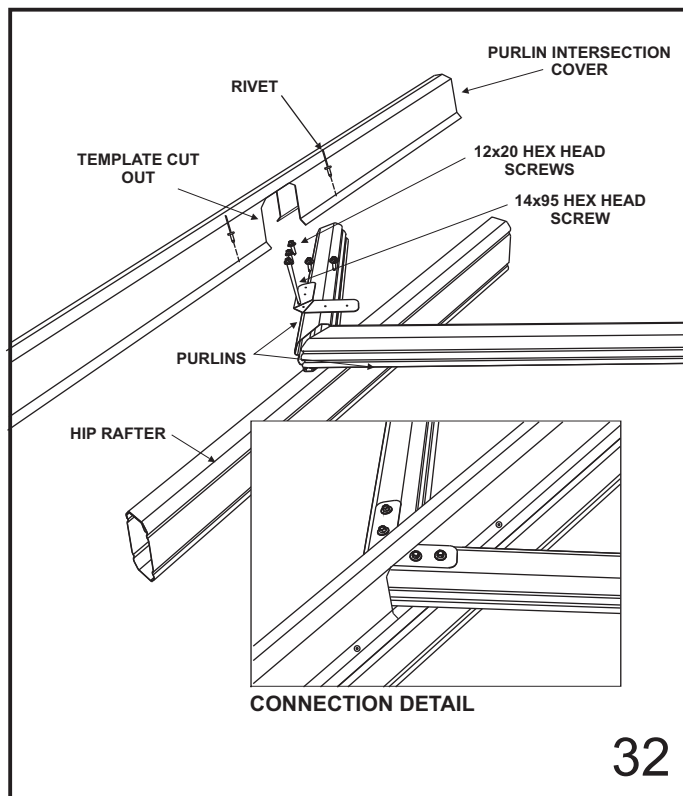

**Note:** Purlin Intersection Caps are available as an optional extra and can be used to fill the small gap between the purlin and the template cut out. Caps are riveted to the side of the purlin cover.

With the exception of Hip Ends with Outback<sup>®</sup> deck, hip support flashings (Figure 2) are secured directly over purlin intersection covers to hide roof sheeting cuts. Fix the flashing to purlins at each purlin junction using a single rivet either side of the flashing.

Mitre hip support flashings at the apex for a neat finish.

## 10.0 REMAINING FRAME ASSEMBLY

Assemble the remaining framework of the verandah as per the installation guide 'Outback Flat Attached Verandahs, Patios & Carports'.

Fix the posts, as described in the installation guide under "COLUMNS AND FOOTINGS" or "ALTERNATIVE FOOTING".

**Note:** All adjustable construction props are to be left in position until decking is attached and concrete is set.

## 11.0 GUTTERING

Connect the gutter to the flat roof Outbacks<sup>®</sup> as described in 'Outback Flat Attached Verandahs, Patios & Carports'. Gutter will continue from the flat roof along the hip fascia beam as detailed below.

Where there is no flat roof adjacent to the gable, the gutter is attached with gutter straps and flat connecting strips which are fixed to the valley beam. Cut the strip into sections and rivet at 1000mm intervals to the valley beam. Fix the gutter to the strip with rivets as shown in Figure 33. Once decking is attached (Section 12.0) the gutter is secured to the roof sheeting using gutter straps at maximum 1200mm intervals. Gutter straps may need to be bent slightly so they can be rivetted to the roof sheets. Waterproof rivets with silicone. This method is also used to fix gutter along the front of the hip fascia beams.

Gutters will need to be mitred at corners. All gutter joints are to be water proofed with silicon.

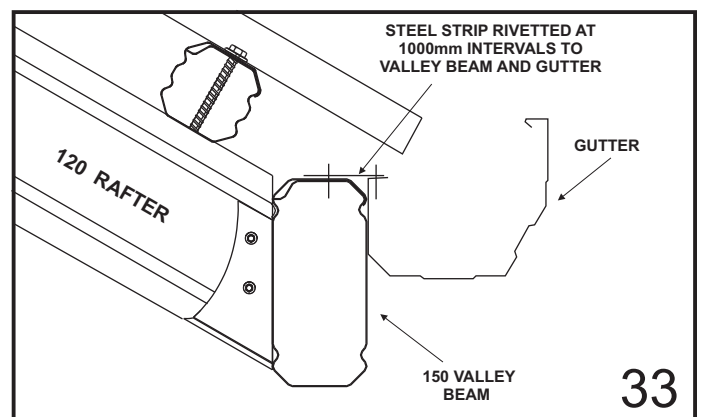

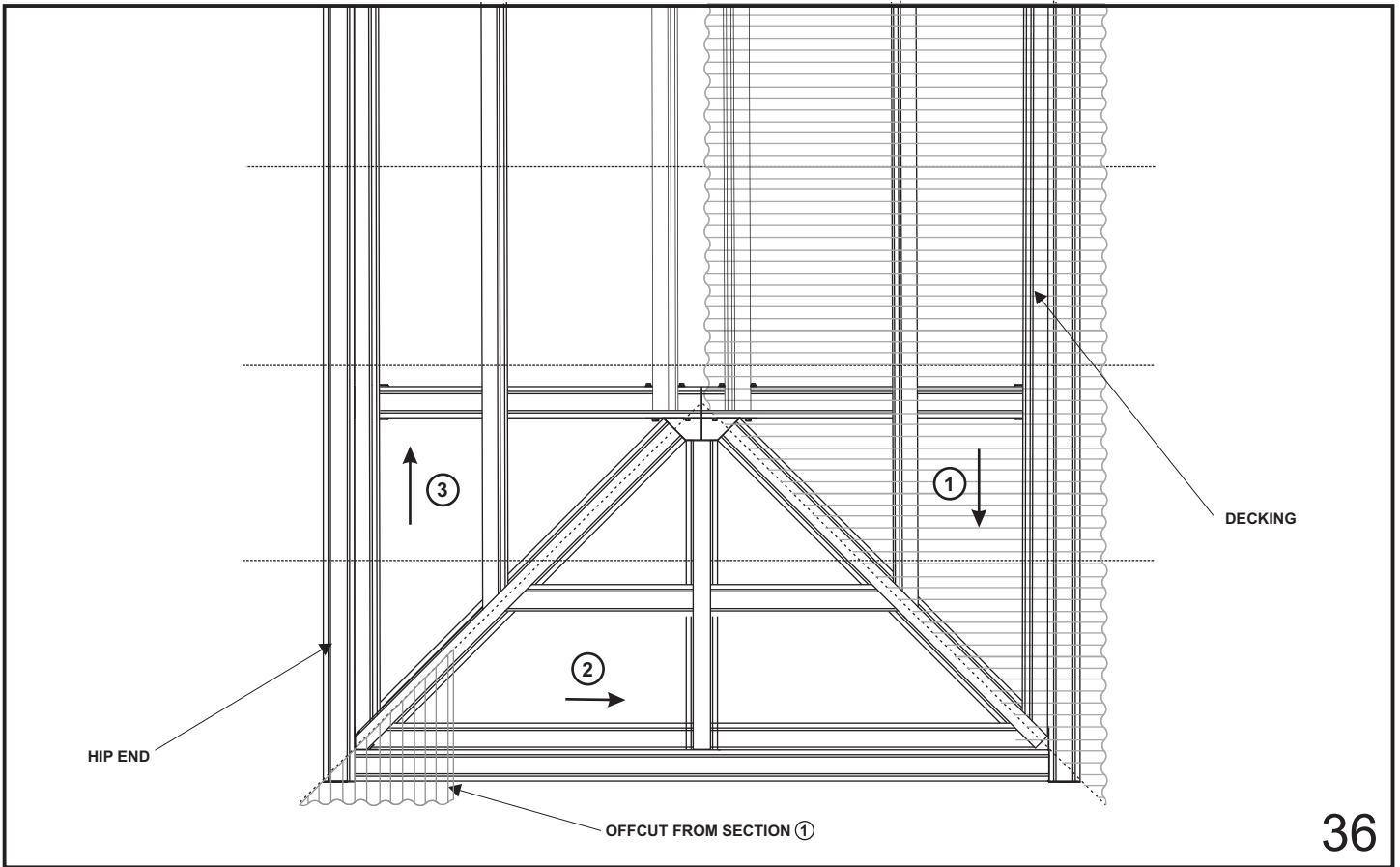

36

**12.0 ATTACH DECKING**

**12.1 FLAT ROOF**

Attach the decking to the flat roof verandah first as laid out under "THE DECKING" ('Outback Flat Attached Verandahs, Patios & Carports'), starting from the valley beam and working away, on both sides.

The back channel is attached upside down (the shorter leg on top) along valley beams to assist the fixing of decking. (Figures 34 and 35). The channel extends to the end of valley beams.

Figure 34 shows the back channel and Outback® deck running parallel fixed to a 150 valley beam. Figure 35 shows the back channel and Outback® deck running perpendicular to a 150 valley beam.

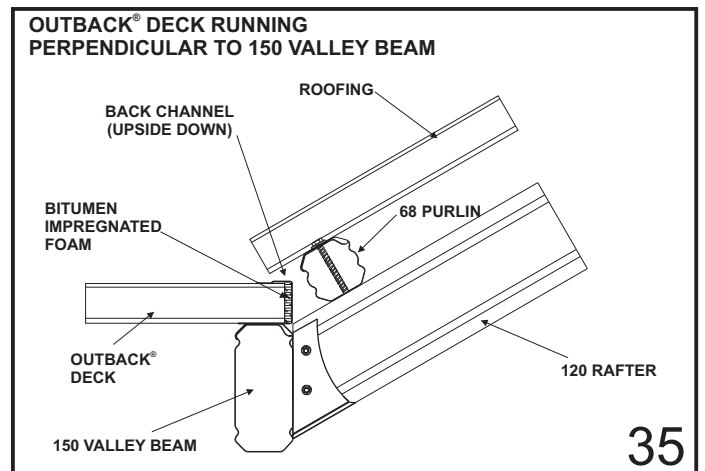

35

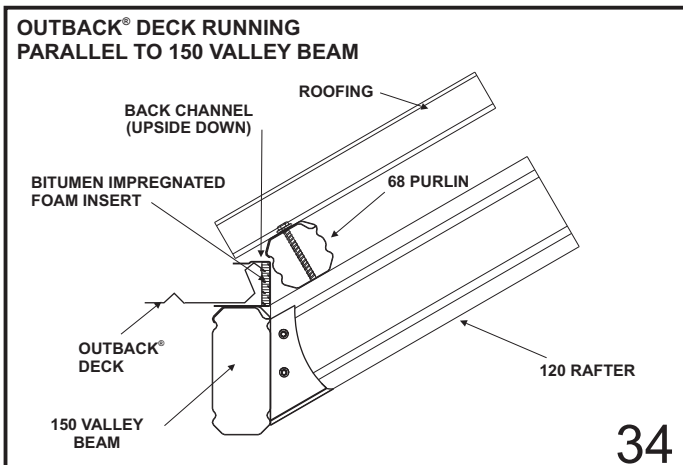

34

**12.2 MULTISPAN GABLE**

When attaching the decking to the gable, start from the rear (non gazebo end) on one side of the gable, aligning the sheets so as to avoid the purlin fixing screws.

If the deck of the flat roof section runs perpendicular to the valley beams, align the ribs of the gable decking up with the flat roof section. Fix the decking so that it is level with the top of the flat deck, and so there is a maximum 100 mm gap at the ridge (Figure 37).

When using Polycarbonate or corrugated roofing no back channel is required at the ridge. When Outback® deck is used, back channel is required at the ridge, and is supplied with the unit (Figure 39).



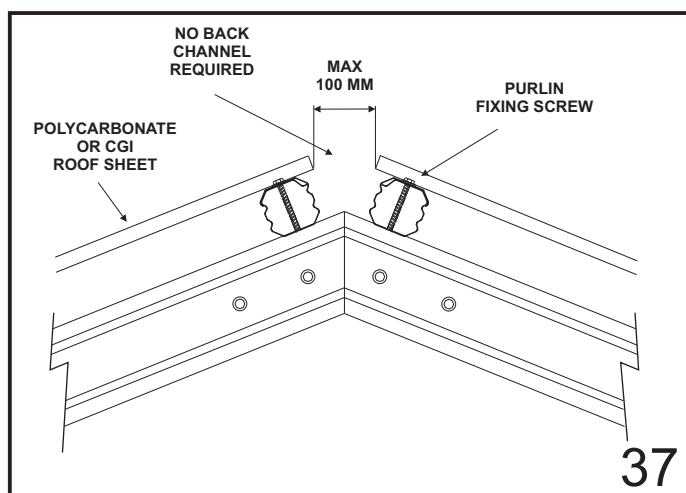

### 12.3 HIP END

At the point when less than one full sheet is required to pass the centreline of the front gable frame on one side, the Hip End decking will need to be cut to suit. Refer to figure 33 for cutting order and laying direction.

Continue laying deck past the end gable frame (Section 1, Figure 36) and cut the sheeting along the centreline of the purlin intersection cover. The offcuts from this section are used in section 2 but deck is laid in the opposite direction as shown by the arrow in figure 36. When all offcuts are utilised begin with new sheeting.

This process is continued around the front of the Hip End and back down the side of the Multispan Gable (i.e. Offcuts from section 2 are used in section 3 with deck being laid in the direction shown in Figure 36).

**Note:** The centreline of the purlin intersection covers are used to mark the sheets for cutting. Sheets are to be taken down from the framework to be cut. It is recommended sheeting is supported in a horizontal plane off the ground at a comfortable height for cutting.

All sheeting which ends at the apex is to be cut to a point so it meets directly above the centre of the front gable frame.

Hip end decking will need to overhang the last purlin and hip fascia beams allowing water to flow directly into the gutter (Figure 33).

The edge of roof sheeting, running along hips, is to be fixed through the hip support flashing and into the purlin intersection cover.

#### 12.3.1 OUTBACK® DECK

If Outback® deck is being used the method previously described and indicated in figure 37 does not apply. Deck is fixed in one direction around the hip end and offcuts are not used. For Outback® deck a special two piece backchannel will be required and is to be located along the purlin cover before the decking is fastened in place (Figure 38). The flashings are screwed to the purlin cover using 12x20 hex head screws at 500mm centres on alternating sides of the shallow ridge. Outback® deck is riveted to the base flashing at 250mm centres.

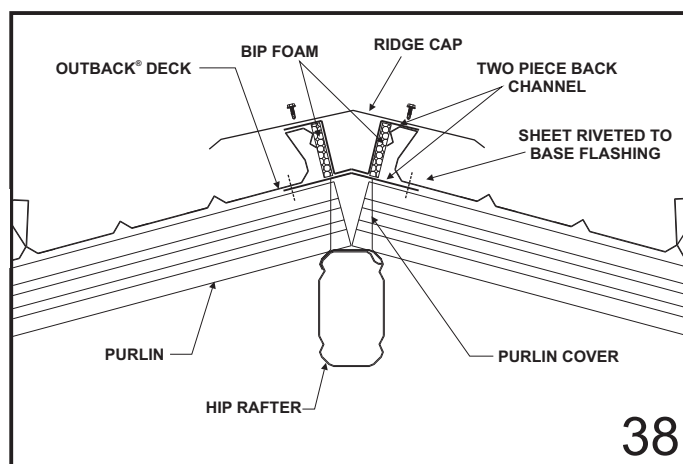

## 13.0 RIDGE CAPPING

### 13.1 MAIN RIDGE

For Outback® deck slide back channel over the ridge end of the deck and rivet into place. Position the ridge cap over the two back channels and screw or rivet into the channel (Figure 39).

For Polycarbonate and Corrugated decking screw or rivet (depending on ridge cap style) the ridge cap directly onto the top of the deck.

**Note:** Do not rivet to polycarbonate decking, screw only.

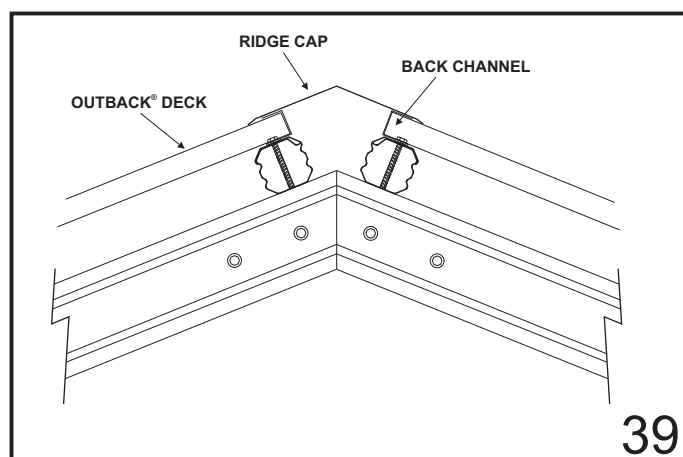

### 13.2 HIP END CAPPING

Ridge cap is also used over all hip end rafters to conceal the line in the deck. For Outback® deck a special back channel is required and should have been installed as described in section 12.3.1. The ridge cap is positioned over the channels and screwed in place through the channels (Figure 38). For Polycarbonate and corrugated decking the cap is screwed directly to the top of the deck. Ridge capping will need to be cut to meet a point at the apex as detailed in figure 40. Allow a 20mm overlap at the ridge. The capping is to be fully silicon sealed at the apex for waterproofing.

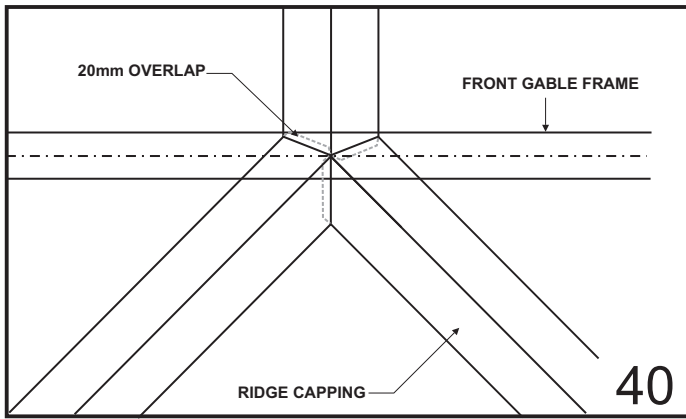

## 14.0 INFILL PANELS

Two styles of header flashings are available to neatly finish the base of infill panels, one is used on header beams with gutter and the other for headers without gutter. Gable infill panels are to be cut in triangular shapes to fit the end frame. Panels can be painted to the desired colour before installing.

End struts are fixed mid-span of the header to a header beam bracket at the base and an end strut plate at the ridge (Figure 41).

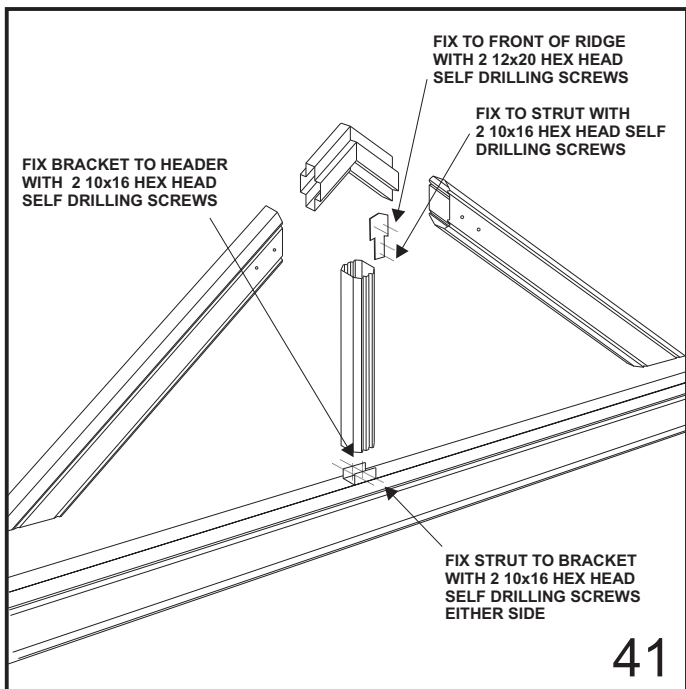

## 14.1 HEADER BEAM WITH GUTTER

Attach the header flashing to the rear gutter lip with rivets. Infill panels are fixed through the top groove of rafters and the end strut with 8x35mm self embedding teks at 500mm centres in non-cyclonic areas and 250mm centres in cyclonic areas. Panels are fixed at the base through the header flashing with split tail soft pull rivets at 500mm centres (Figure 42).

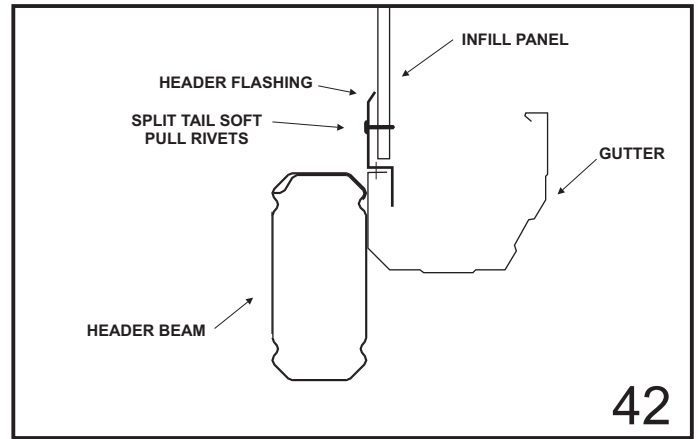

## 14.2 HEADER BEAM WITHOUT GUTTER

Infill panels are fixed through the top groove of rafters and the lower groove of the header beam with 8x35mm self embedding teks. Fix at 500mm centres in non-cyclonic areas and 250mm centres in cyclonic areas. Panels are fixed to the end strut at the same spacings. Attach the header flashing to the underside of the header beam with 10x16 hex head screws to neatly finish the base of the infill panels (Figure 43).

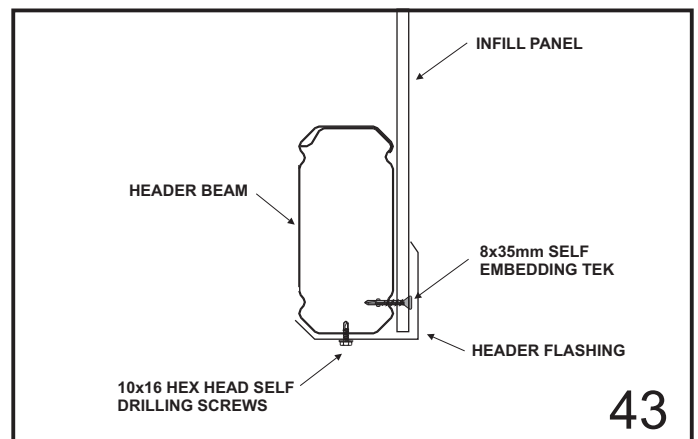

## 15.0 ATTACHING BARGE CAPPING

If barge capping is required at the opposite end to the gazebo, attach the barge cap by screwing the lower lip to the rafter and screw the top section to the purlin through the deck, as shown in figure 44. Mitre the barge at the apex of the gable for a neat finish. Run the barge cap along the gable section to where it meets the flat verandah deck and finish neatly.

If infill panels have been installed, the lower lip of the barge capping should cover the panel screws to give a neat finish.

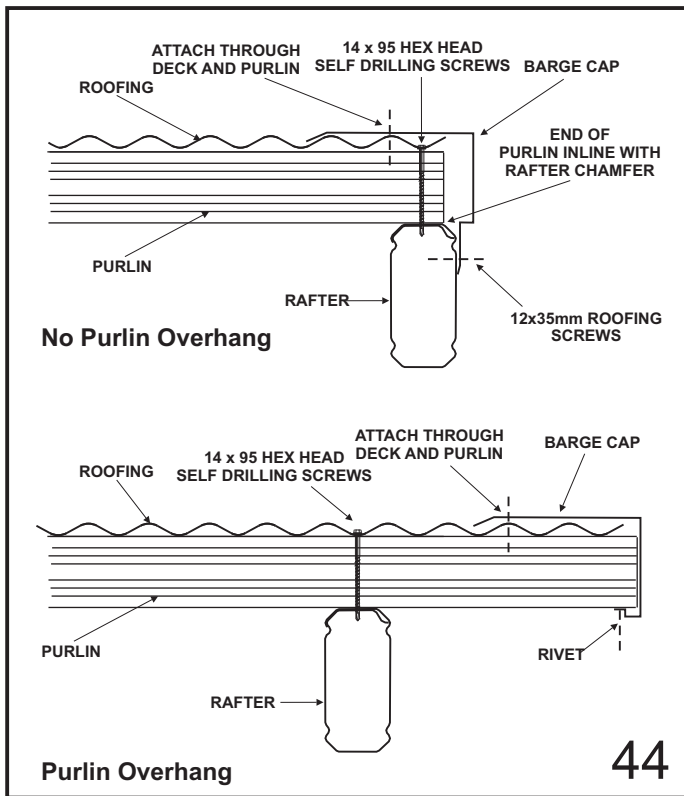

## 16.0 HELPFUL TIPS

Leave plastic coating on members until they are about to be fastened to the structure. This will help prevent scratching of the colorbond finish.

Sweep the roof and clean gutters after the completion of work. Ensure any swarf and rivet stubs are removed as they can cause unsightly rust stains.

Do not allow soil to remain in permanent contact with the columns, as corrosion will result in the base of the column. Refer to the "Selection, Use and Maintenance of Stratco Steel Products" brochure for complete details of the maintenance requirements.

Double check all measurements and drilling locations before proceeding.

Regularly check framework for squareness and vertical alignment to make sure it hasn't moved during construction.