





SPACE-SAVER 2 SHELF UNIT

SPACE-SAVER SHELF INSTALLATION GUIDE

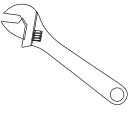

BEFORE YOU START

To ensure that the installation and erection of your Stratco Space-Saver Shelf proceeds smoothly you should confirm that all the components and materials in this installation guide, have been supplied. Carefully read this installation guide to familiarise yourself with all the steps involved, and ensure that you have the correct tools and equipment for the job. Please ensure gloves and safety protection is worn when handling and assembling the shelving unit and components.

TOOLS REQUIRED

 <p>Adjustable Spanner</p>	 <p>Power Drill</p>	 <p>Phillips Head Screw Driver</p>
---------------------------------------------------------------------------------------------------------------	--------------------------------------------------------------------------------------------------------	-----------------------------------------------------------------------------------------------------------------------

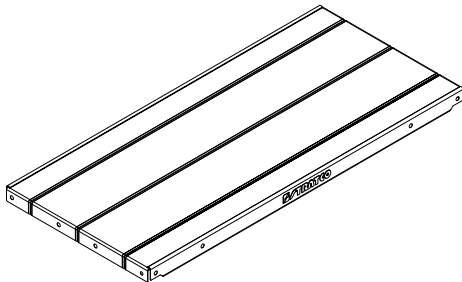
COMPONENTS

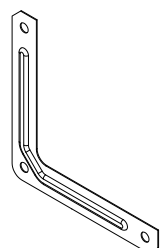
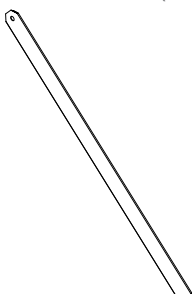
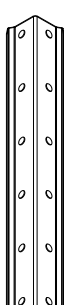
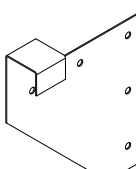
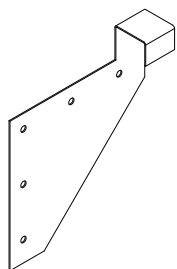
<p>A. SHELF (x2)</p> 	<p>B. CORNER STIFFENER (x4)</p> 	<p>C. ANGLE BRACKET (x6)</p> 	
<p>D. GUSSET STRAP (x4)</p> 	<p>E. LEG BRACKET (x3)</p> 	<p>F. HOOK BRACKET (LEFT) (x1)</p> 	<p>G. HOOK BRACKET (RIGHT) (x1)</p> 

COMPONENT LAYOUT

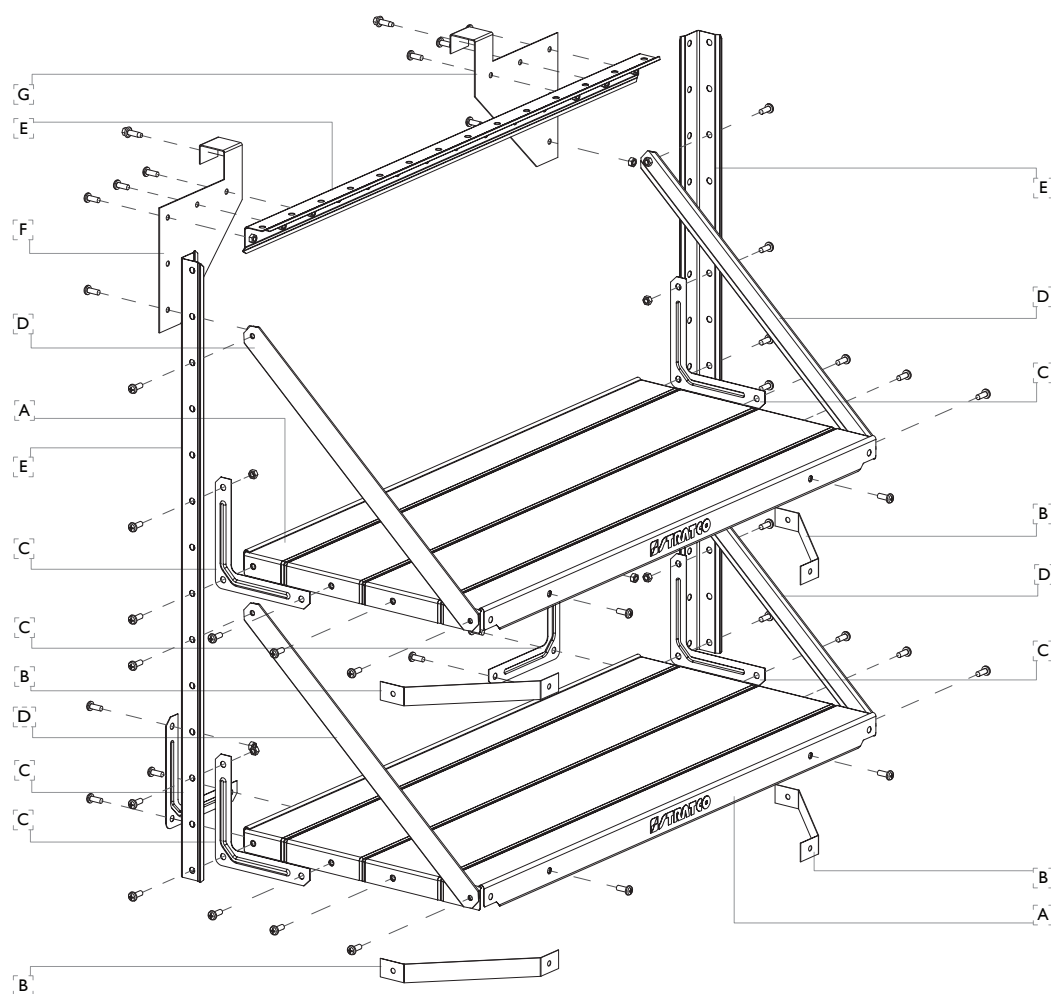

COMPONENT LIST

- A. SHELF
- B. CORNER STIFFENER
- C. ANGLE BRACKET
- D. GUSSET STRAP
- E. LEG BRACKET
- F. HOOK BRACKET (LEFT)
- G. HOOK BRACKET (RIGHT)
- H. 10X16 HEX HEAD SELF DRILLING TEK SCREWS
- I. M5X8 PHILLIPS HEAD SCREWS & HEX NUTS

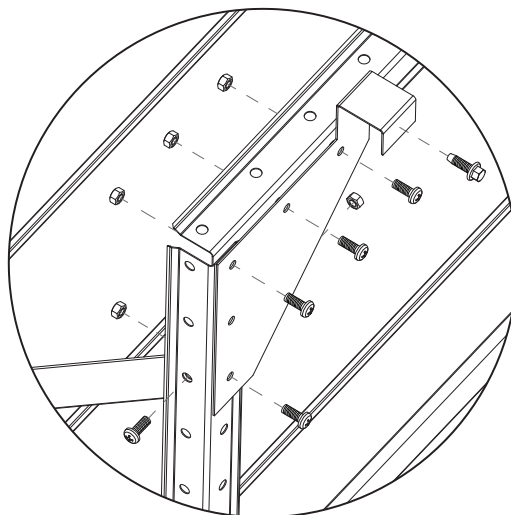

NOTE: Each shelf holds 25kg distributed load.



« Scan this QR code with your smart phone to find a Stratco near you.
 QUEENSLAND • NEW SOUTH WALES • VICTORIA
 AUSTRALIAN CAPITAL TERRITORY • SOUTH AUSTRALIA
 WESTERN AUSTRALIA • NORTHERN TERRITORY

All brands and logos/images accompanied by ® or ™ are trade marks of Stratco (Australia) Pty Limited.
 CODE SS-10027 FORM S-999 © Copyright October 2017

Ph: 1300 155 155
stratco.com.au